



Jackson County, Indiana

Subdivision Control Ordinance

*Adopted August 5, 2008
Ordinance # 2008-2*

Table of Contents

I. General Provisions	4
A. Title	4
B. Authority.....	4
C. Policy.....	4
D. Purpose	4
E. Applicability and Jurisdiction	5
F. Classification of Subdivisions	5
G. Conflicts and Consistency	6
H. Compliance.....	6
I. Severability	7
J. Effective Date and Transitional Provisions.....	7
K. Preparation by Surveyor	8
L. Minimum Standards.....	8
M. Compliance Required for Permit Issuance.....	9
II. Administration	10
A. Administration and Decision-Making Bodies	10
B. Amendments	11
C. Modifications	12
D. Appeals.....	13
III. Exempt Subdivisions	14
IV Minor Subdivisions	16
A. General	16
B. Primary Approval	18
C. Secondary Approval.....	20
D. Minor Subdivision Review Process.....	20
E. Amendment.....	23
F. Appeal	23
G. Recording	23
V. Major Subdivisions	24
A. General	24
B. Concept Plan	24
C. Primary Approval	26
D. Secondary Approval	30
E. Major Subdivision Approval Process	30
F. Phases.....	34
G. Recording	34
VI Conservation Subdivisions	35
A. Purpose	35
B. Objectives	35
C. Authority and Applicability	35
D. Maximum Development Density and Dimensional Requirements.....	35
E. Open Space Requirements	39
F. Protection and Management of Open Space.....	41
G. Design Standards	43
H. Pre-application Meeting Required	45
I. Subdivision Application Requirements and Review Process.....	45
J. Subdivision Application.....	49
VII. Development & Design Standards	51
A. Minor Subdivisions	51
1. General Requirements	51
2. Lots.....	51
3. Streets and Access	52

4. Water Supply	53
5. Sewage Disposal	53
6. Drainage	53
B. Major Subdivisions	54
1. General Requirements	54
2. Lots	55
3. Blocks	57
4. Driveways	60
5. Streets and Access	61
6. Street Signage	69
7. Street Lighting	70
8. Bridges and Culverts	70
9. Landscaping	71
10. Easements	72
11. Storm Water Storage	72
12. Drainage and Stormwater	74
13. Water Supply	75
14. Sewage	76
15. Pedestrian Facilities	78
16. Monuments and Markers	81
17. Public Sites, Common Areas and Open Space	82
18. Survey, Plans and Plat Standards	83
19. Improvement Plans	83
VIII Improvements and Financial Guarantees	85
A. Completion of Improvements	85
B. Secondary Approval and Performance Guarantees	85
C. Maintenance Guarantees	86
D. Form of Financial Guarantees	86
E. Release of Financial Guarantees	86
F. Inspection	87
IX Enforcement and Penalties	88
A. Plat Validity	88
B. Complaint	88
C. Civil Subdivision Control Violations	88
D. Citation for Civil Subdivision Control Violations	89
E. Trial for Civil Subdivision Violations	90
X Definitions & Interpretation	92
Appendix A -- Certificates & Notations	102
1. Surveyor certificate	102
3. Primary Approval Certificate	104
4. Secondary Approval Certificate	105
5. Plat committee minor plat approval	106
6. Improvement Plans Certificate	107
7. Dedication Certificate	108
8. Tax certificate	109
9. Flood hazard notation	110
10. Private access easement or street notation	111
11. Recording notations	112
12. Replat notation	114
13. Sewage System Covenant	115

Chapter 6, Jackson County Code

I. General Provisions

A. Title

This Ordinance shall be known as, referred to, and cited as the "Subdivision Control Ordinance of Jackson County, Indiana," and is hereinafter referred to as "this Ordinance. "

Indiana Code (IC) 36-7-2-2, authorizes the planning and regulation of real property by platting or subdividing.

IC, 36-7-4-700, is the enabling legislation in this area.

B. Authority

This Ordinance is adopted pursuant to IC, 36-7-4-700, SUBDIVISION CONTROL, and any amendments thereto. In accordance with the provisions of said statute, the Jackson County Plan Commission (hereinafter called "Commission") has exclusive control over the approval of plats and re-plats involving unincorporated land within the County.

C. Policy

1. It is declared to be the policy of Jackson County to consider the subdivision of land and subsequent development of the land as subject to control of the County pursuant to the Comprehensive Plan for the orderly, planned, efficient, and economical development of the County.
2. Land to be subdivided shall be of such character that it can be used safely for building purposes without danger to health or peril from fire, flood, or other menace, and land shall not be subdivided until adequate infrastructure and services exist or are guaranteed in accordance with Section ___, and proper provision has been made for drainage, water, sewerage, and public facilities such as parks, recreational facilities, streets, and sidewalks.
3. All modifications of existing and proposed improvements shall conform with and be properly related to the Comprehensive Plan and the standards contained in other applicable ordinances and regulations.

The Jackson County Comprehensive Plan was adopted by the County Commissioners on September 19, 2006, Resolution 2006-4.

D. Purpose

This Ordinance is adopted for the following purposes:

1. To protect and provide for the public health, safety, and general welfare of the County.
2. To guide the future development of the County in accordance with the Comprehensive Plan and any related policies.

3. To provide for the safety, comfort, and soundness of the built environment and related open spaces.
4. To protect the compatibility, character, economic stability and orderliness of all development through reasonable design standards.
5. To insure that adequate public facilities will be provided in conjunction with new development.
6. To ensure quality installation of improvements that shall be later maintained by the County;
7. To supply proper land boundary records:
 - a. To provide for the survey, documentation, and permanent monumentation of land boundaries of property.
 - b. To provide for identification of property.
 - c. To provide public access to land boundary records.

E. Applicability and Jurisdiction

The provisions of this Ordinance shall apply to all lands within the County, except for those incorporated cities and towns within Jackson County, including land owned by local, county, state, or federal agencies, to the extent allowed by law. For land within a municipality's extra-territorial planning jurisdiction, roads and associated drainage shall meet the county's standards in order to be accepted by the Jackson County Commissioners as public county roads.

Incorporated cities and towns within Jackson County include: Brownstown, Crothersville, Medora and Seymour.

F. Classification of Subdivisions

This Ordinance addresses three different classifications of land divisions. In order to determine which class of subdivision a proposed land division best fits, the applicant or his/her representative is encouraged to discuss with the Office of the Building Commissioner the nature of the land division being proposed, prior to submitting any of the materials required by this Ordinance. Based upon the information provided at this conference, the Office of the Building Commissioner will provide the applicant a preliminary opinion as to the classification of the subdivision and which application and review procedure applies to that type of subdivision. Failure to hold this conference and/or to provide complete and accurate information to the Office of the Building Commissioner at this stage may cause delays in formal consideration of the subdivision.

All land to be divided within Jackson County shall be categorized into one of three types of subdivisions, in accordance with this Ordinance:

1. Minor Subdivision
2. Major Subdivision

3 Conservation Subdivision

G. Conflicts and Consistency

1. Conflicts and Relationship with Other Regulations

When the provisions of this Ordinance are inconsistent with one another, or when the provisions of this Ordinance conflict with provisions found in other ordinances, codes, or regulations adopted by Jackson County, the more restrictive provision shall govern unless the terms of the provisions specify otherwise. It shall be the developer's or applicant's responsibility to determine and comply with all other applicable county, county, state, or federal codes or regulations governing development and land use activities.

2. Relationship with Private-Party Easements, Covenants, or Agreements

This Ordinance is not intended to interfere with or abrogate any easements, covenants, or agreements between parties, provided that wherever this Ordinance proposes a greater restriction upon the use of buildings or land, upon the location or height of buildings or structures, or upon requirements for open areas than those that are imposed or required by such easements, covenants, or agreements between parties, the provision of this Ordinance shall govern. In no case shall the County be obligated to enforce the provisions of any easements, covenants, or agreements between parties.

H. Compliance

All land subdivided or platted under the terms of this Ordinance shall comply with the minimum standards prescribed in the zoning ordinance of current adoption. The Commission shall not have the authority to approve any subdivision that does not comply with said Ordinance. For subdivisions of land within the zoning jurisdiction of another unit of government, the zoning laws of the unit having such jurisdiction shall apply.

1. No lot other than a legal lot of record or an exempt parcel split shall be sold nor advertised for sale; no permit to erect any building upon land in a subdivision shall be issued; and no building shall be erected in a subdivision, unless and until a final major subdivision plat or minor plat has been approved and recorded.
2. For subdivisions recorded after a financial guarantee is posted for the improvements, no occupancy permit shall be issued for any building unless in addition to all requirements of the building code, the following improvements are in place to provide for safe access to the building(s) for the occupants and for emergency vehicles:

- a. Streets having a compacted subgrade and a binder course
- b. Traffic control signs and street name signs

3. Minimum Requirements

The provisions of this Ordinance shall be held to be minimum requirements necessary for the promotion of the public health, safety, and general welfare, and shall be liberally construed in favor of the County and shall not be construed to be a limitation or repeal of any other power now possessed by Jackson County.

I. Severability

If any Court of competent jurisdiction rules any provision of this Ordinance invalid, that ruling shall not affect any provision not specifically included in the judgment. If any Court of competent jurisdiction rules invalid the application of any provision of this Ordinance to a particular property, building, or other structure, or use, that ruling shall not affect the application of the Ordinance provisions to any property, building, other structure, or use not specifically included in the judgment.

J. Effective Date and Transitional Provisions

1. Effective Date

This Ordinance shall take effect after publication of the notice of adoption as provided by IC 36-7-4-701.

2. Violations Continue

Any violation under previous ordinances repealed by this Ordinance shall continue to be a violation under this Ordinance and be subject to penalties and enforcement under Ordinance ___, unless the use, development, construction, or other activity complies with the provisions of this Ordinance.

3. Approved Projects

- a. Any Commission approval of a primary plat granted before the effective date of this Ordinance shall remain valid, provided that the secondary plat is approved within 120 days after such effective date.
- b. Any Commission approval of a secondary plat granted before the effective date of this Ordinance shall remain valid, provided that the secondary plat is recorded in the Office of the County Recorder within 180 days after such effective date.

4. Complete Applications

- a. Any project for which a complete application was submitted and accepted by the County prior to the effective date of this Ordinance may, at the applicant's option, be reviewed wholly

under the terms of the previous Subdivision Control Ordinance. If approved, these projects may be carried out in accordance with the standards in effect at the time of application. Any re-application for an expired permit shall meet the standards in effect at the time of re-application.

- b. Projects for which no application has been submitted and accepted as complete prior to the effective date of this Ordinance shall be subject to all requirements and standards of this Ordinance.

K. Preparation by Surveyor

1. All plats and surveys shall be prepared by or under the direct supervision of a professional land surveyor licensed in accordance with the laws of the State of Indiana, who shall be responsible for the monumentation thereof.
2. Infrastructure improvements shall be constructed in accordance with plans and specifications prepared by a licensed engineer or land surveyor and approved by the Commission. Unless otherwise specified in the subdivision agreement, the licensed person who prepared the infrastructure improvement drawings shall be responsible for the stakeout, inspection, and certification of completion in accordance therewith. If the person specified in the subdivision improvement agreement is not able to perform this duty, he shall give notice by registered mail to the Commission and like notice to any person, firm, or corporation guaranteeing the installation of the improvements. No work on such infrastructure improvements shall commence until a subdivision improvement agreement has been duly executed.

L. Minimum Standards

The standards contained in this Ordinance and in the zoning ordinance are minimum standards. In any case where another Ordinance contains stricter or more stringent standards than those contained in this Ordinance, the stricter standards shall apply. The Commission may require stricter

standards when, in the opinion of the Commission, those stricter standards are needed to fulfill the intent and purpose of this Ordinance.

M. Compliance Required for Permit Issuance

No building permit, improvement location permit, or certificate of occupancy shall be issued for, nor any structural improvements be commenced upon, any parcel of land which was created by subdivision after the effective date of and not in conformity with the provisions of this Ordinance. No land shall be sold, leased, or offered for sale or lease unless such is in conformity with the provisions of this Ordinance. No road shall be laid out or constructed unless it is consistent with the Jackson County Transportation Plan and/or has been approved by the Commission as part of a subdivision.

II. Administration

A. Administration and Decision-Making Bodies

1. Board of County Commissioners

- a. In accordance with IC 36-7-4-701, the County Commissioners shall, in the zoning ordinance, designate the districts in which subdivision of land may occur.
- b. The County Commissioners shall adopt the Subdivision Control Ordinance and any amendments thereto.
- c. The County Commissioners shall accept appropriate performance guarantees, and maintenance guarantees, and shall take such actions as necessary to enforce the terms of those guarantees.
- d. The Board of County Commissioners shall accept dedications of rights-of-way or public improvements on behalf of the County.

2. Plan Commission

- a. In accordance with IC 36-7-4-701, after the Subdivision Control Ordinance is adopted, the Jackson County Plan Commission has exclusive authority over the approval of subdivisions. Note that the county plan commission does not have exclusive authority to approve subdivisions within the extra-territorial planning area of any municipality within Jackson County; that authority belongs to the respective municipality.
- b. In accordance with IC 36-7-4-704, the plan commission shall adopt uniform fees proportioned to the cost of checking and verifying proposed plats.
- c. The Commission shall, in accordance with IC 36-7-4-705, establish uniform rules with regard to investigations and hearings and shall maintain accurate records of proceedings before the Commission.
- d. The Plan Commission shall appoint the members of the Plat Committee, as provided by IC 36-7-4-701 and the Commission's Rules of Procedure.
- e. The Plan Commission shall appoint a Technical Review Committee to assist them with the review of proposed subdivisions. Membership and procedures of the technical review committee shall be identified in the Commission's Rules of Procedure. The Technical Review Committee may make a recommendation to the plat committee or the plan commission regarding a proposed subdivision.
- f. The Plan Commission shall conduct public hearings and make written findings as to whether the proposed subdivision

See the Rules of Procedure for the Jackson County, Indiana Plan Commission.

complies with the standards of this Ordinance. If the subdivision complies, the Plan Commission shall grant Primary Approval to the subdivision. In granting Primary Approval, the Plan Commission shall attach such conditions as are necessary to ensure that the subdivision complies with the standards of this Ordinance.

- g. If the applicant submits a Concept Plan, the Plan Commission shall review the plan and offer guidance to the applicant as to the acceptability of the plan and its conformity to the standards of this ordinance. The Plan Commission may approve the Concept Plan with or without conditions, or it may reject the Concept Plan and provide the applicant with the reasons for the rejection.

3. Plat Committee

- a. A Plat Committee is hereby established in accordance with IC 36-74-701. The membership shall be as described in the Plan Commission Rules of Procedure.
- b. The Plat Committee is authorized to grant Primary Approval, without notice or hearing, of a minor subdivision that complies in all respects with the standards of this ordinance, subject to the right to appeal to the Plan Commission.
- c. The Plat Committee shall keep accurate records of its proceedings and shall operate in accordance with the Plan Commission Rules of Procedure.

4. Staff

- a. The staff is hereby designated to administer and interpret this Ordinance. Any staff interpretation of the ordinance may be appealed to the Plan Commission.
- b. The staff shall accept applications and filing fees for subdivisions.
- c. In accordance with IC 36-7-4-705, the staff shall review proposed subdivisions for technical conformity with the standards set forth in this Ordinance and shall set a date for a public hearing on each proposed subdivision.
- d. The staff is hereby authorized to grant Secondary Approval to minor subdivisions, provided that the staff finds that all conditions of Primary Approval have been met.

B. Amendments

This Ordinance may be amended in accordance with IC 36-7-4-701.

C. Modifications

1. The Commission may grant such modifications to the requirements and standards of this Ordinance as will not be contrary to the public interest, where owing to extraordinary conditions, fully demonstrated by the applicant on the basis of facts presented, strict compliance with the provisions of this Ordinance will result in practical difficulties or misuse of property. It is the intent of this Ordinance that this authority will be used sparingly and only when the applicant has clearly demonstrated that all criteria listed below are met. The burden of proof is on the applicant.

In the exercise of its authority under this section, the Commission shall grant modifications only upon finding that all of the following criteria are met:

- a. The modification will not be detrimental to the public health, safety, or general welfare;
 - b. The modification will not adversely affect adjacent property;
 - c. The modification is justified because of exceptional topographic or other physical conditions unique to the property involved and is not to correct mere inconvenience or financial disadvantage;
 - d. The conditions upon which the modification request is based are unique to the property for which the relief is sought and are not applicable generally to other property;
 - e. The modification is consistent with the intent and purposes of this Ordinance and with the Comprehensive Plan;
 - f. The condition necessitating the modification was not created by the owner or applicant;
 - g. The relief sought will not in any manner vary the provisions of the Zoning Ordinance.
2. In granting modifications, the Commission may require such conditions as will, in its judgment secure substantially the purposes of this Ordinance.
 3. A request for a modification from the terms of this Ordinance shall be submitted in writing at the time when the subdivision is filed with the Commission for consideration for Primary Approval. The request shall state fully the grounds for the application and all facts relied upon by the applicant. If during the course of their review, the Technical Review Committee or the staff discovers the need for a modification, the Building Commissioner shall inform the applicant and give him/her the option of applying for such modification.
 4. It is not within the jurisdiction of the BZA to grant modifications or variances to these subdivision regulations.

The plan commission shall not approve modifications unless it shall make findings based upon the evidence presented to it by the applicant, as addressed on the prescribed PC form.

D. Appeals

Any person aggrieved by a decision of the PC relating to the Subdivision Control Ordinance may appeal said decision to the Jackson County Circuit Court as provided by Indiana law. The appeal shall be filed within 30 days of the date of the decision upon which the grievance is based.

Per IC 36-7-4-1016, a plan commission's final decision on a subdivision may be reviewed by certiorari procedure.

III. Exempt Subdivisions

A. Exempt Subdivisions

1. Purpose and Intent

It is the intent of this section to provide a streamlined procedure for simple subdivisions or changes in lot lines. Those divisions of land or resubdivisions that do not substantially affect the comprehensive plan, do not require extensions of streets or utilities, and have minimal impact on the development pattern of Jackson County are exempt from the requirements for Plan Commission or Plat Committee approval.

2. Applicability

The provisions of this Section apply to the following divisions, which are classified as exempt for the purposes of this ordinance:

- a. The division of land into no more than three parcels, sites or lots of at least one acre, not involving any new streets or access easements, provided that:
 1. Proof is provided that each parcel, site or lot created can support two subsurface on-site sewage disposal sites or one repairable on-site sewage system according to the Jackson County Health Department
 2. Each parcel complies with the minimum lot size and all other applicable Zoning Ordinance requirements
 3. Each parcel has 50' minimum frontage with a minimum lot width of 150', as measured at the front building setback line.
- b. The division of land into no more than three parcels, sites or lots of at least five acres, not involving any new streets or access easements, provided that the parcels, sites or lots are labeled "unbuildable", unless proof is provided that each parcel, site or lot created can support two septic field sites according to the Jackson County Health Department.
- c. A resubdivision which involves only the removal of interior lot lines, with the outside perimeter of the property remaining unchanged, resulting in fewer parcels than were contained in the original parcel;
- d. A resubdivision which involves only the changing of notations written on the plat or correction of errors thereon;

- e. A division of land pursuant to an allocation of land by court decree;
- f. The division of land into cemetery plots;
- g. A resubdivision to correct errors in an existing legal description, provided that no additional building lots are created;
- h. A division of land for the sale or exchange of tracts between adjoining land owners, provided that no additional building sites are created, and that each land owner provides a new property description, prepared by a licensed, registered land surveyor, so no new tax parcel is created.
- i. A division or resubdivision of land for the acquisition by the public or by a utility for street right-of-way or easement.
- j. A division of land for the purpose of agriculture, as long as parcels are labeled as “unbuildable”.

3. Limitations

- a. In no case shall more than three parcels be created from a parent tract utilizing this exempt subdivision process. A parent tract shall be considered as a parcel that is in existence at the time of the passage of this ordinance. Subdivision of parcels shall be considered cumulative over time.
- b. An exempt subdivision shall not gain access from an access easement.

4. Standards

- a. The applicant shall provide for all proposed undeveloped parcels, except those labeled as “unbuildable,” proof of preliminary septic approval from the Jackson County Health Department.
- b. All proposed exempt subdivisions shall be submitted with a survey and a legal description prepared by a land surveyor.

5. Approval and Recording

- a. All exempt subdivisions shall be submitted to the Jackson County Building Commissioner for review.
- b. If the building commissioner determines that the proposed subdivision meets the standards to be exempt from the subdivision plat process, he/she shall stamp the exempt subdivision as approved. The Jackson County Auditor shall not accept an exempt subdivision for recording unless it has been stamped as approved by the Building Commissioner.

A parent tract shall be a tract that is legally in existence at the time of passage of this ordinance, according to county records.

IV Minor Subdivisions

A. General

1. Purpose and Intent

The purpose of a minor subdivision is to provide a simplified review and approval procedure for certain land divisions. Minor subdivisions require primary and secondary approval, in accordance with the procedures set forth in the Jackson County Plan Commission Rules of Procedure.

2. Applicability

A proposed subdivision may be processed under the provisions of this Section if there will be no opening of new public streets or substantial improvement to existing streets, if water or sewer utilities are not being extended, and if the proposed subdivision complies in all respects with the provisions of this Ordinance. The Minor Subdivision procedure may be used to create no more than seven lots from a single parent tract over any period of time. Additional lots will require submission of a Major Subdivision.

After a subdivision request has been filed, the planning director shall determine whether the petition may be considered as a minor subdivision. The planning director's decision may be appealed to the Commission.

2. Eligibility

Before determining that a subdivision is eligible to be considered under this Ordinance, the planning director shall find that all of the following criteria are satisfied:

- a. Orderly Development -- The subdivision will not impede orderly development of land or the provision of public services and improvements.
 1. The subdivision will not interfere with the implementation of the Comprehensive Plan.
 2. The subdivision will not interfere with the provision of roads to provide access to adjoining or nearby property in the event that such property is developed in the future.

- b. Utilities and Drainage -- All parcels in the subdivision will have adequate utilities and drainage.
 1. All lots shall be served by a sanitary sewer or other sewerage system approved by the Indiana State Department of Health, or they shall have the capability to contain sites for two subsurface disposal systems which comply with all requirements of the Indiana State Department of Health and

IC 36-7-4-701 (d) states that the Plan Commission may delegate primary approval authority for some subdivisions to the commission's Plat Committee. Jackson County's Minor Subdivision qualifies for this method of approval.

- the Jackson County Health Department. Any subdivision of land that requires the extension of existing sewers or the construction of new treatment facilities shall be considered as a major subdivision. If extension of sewer service is found to be a feasible alternative and is desirable because of soil conditions, topography, lot sizes, or other factors, the petition shall be considered as a major subdivision.
2. All lots shall be served by a public or quasi-public water system or shall have the capability to contain a well, which complies with all requirements of the Indiana State Department of Health and the Jackson County Health Department.
 3. All lots shall be provided with drainage improvements as necessary to comply with the requirements this ordinance.
- c. Access -- All parcels in the subdivision and adjacent land will have adequate ingress and egress without the construction of any new streets or substantial improvement to existing streets.
1. All lots will have legal access to a platted private street or to a public street which has been accepted for maintenance by, or has been continuously maintained for a period of 10 years immediately preceding the filing of the subdivision, by a public agency regularly having responsibility for such maintenance. Such public street also has a gravel or hard surface suitable for vehicular traffic which is at least 18 feet of pavement or gravel in width along the lot frontage(s), is in good repair, and has a geometry which is suitable for the traffic which it will carry after the proposed subdivision.
 2. Frontage on limited access streets on which driveways cannot open shall not constitute legal access.
 3. If by reason of topography, natural or man-made features, or other conditions relating to the property requested for subdivision, better access can be provided through construction of a new street, the petition shall be considered as a major subdivision.
 4. All lots will have driveway locations that will provide for adequate sight distance and will be properly spaced according to County standards.
 5. Land adjacent to the property involved in the subdivision also will have adequate access according to the criteria contained in this section.
 6. All access easements shall be 50' wide minimum.

- d. Suitability -- All lots in the subdivision will provide suitable building Sites for the purpose for which the land is to be used. Land suitability shall be determined by the criteria contained in this Ordinance.
- e. Endangerment. The subdivision will not be detrimental to nor endanger the public health, safety, or general welfare.

3. Filing

- a. An application for approval of a Minor Subdivision shall be filed with the Office of the Building Commissioner on forms specified by that office.
- b. Applications for Minor Subdivisions shall contain all required materials as specified in the Plan Commission Rules of Procedure.

B. Primary Approval

- 1. Submission -- All subdivisions of land meeting the definition of **“SUBDIVISION MINOR,”** in the Definitions section of this ordinance may be submitted to the Plat Committee or Commission for primary approval as specified in this section.
- 2. Required Submission Materials -- All requests for primary approval of a minor subdivision shall be submitted with the items listed in this section.
 - a. Filing Fee -- Each minor subdivision submitted for review shall be accompanied by the required filing fee as established by the Commission.
 - b. Primary Plat -- An original drawing prepared by a registered public surveyor, in accordance with the survey and drafting standards set forth in this ordinance and copies (with the number to be specified by the Commission) showing the following:
 - 1. Legal description of the subdivision.
 - 2. Bar scale (the scale shall be 50 feet to the inch or larger, unless the property involved in the subdivision is of a size or shape which requires a smaller scale to fit on the required sheet size, in which case another scale approved by the Commission may be used).
 - 3. Lot numbers, dimensions, and sizes in square feet or acres.
 - 4. Boundary lines of floodway and floodway fringe areas on each lot as scaled from the flood plain district maps of current adoption by the County, appropriately labeled.
 - 5. Any easements (existing or proposed, including but not limited to utility easements, drainage easements, access easements,

- etc.), legal drains, and easements to be vacated by the subdivision with notations regarding the vacation.
6. Rights-of-way as established by the Transportation Plan.
 7. Location map.
 8. All applicable certificates and notations as contained in this ordinance.
 9. For subdivisions containing land with a slope of 10 percent or greater as determined by the Soil Survey of Jackson County, the topography as shown on the USGS quad sheets. The topography may be shown on a separate print, but it shall be shown at a scale no smaller than 1" = 300'.
- c. Supporting Material. The following supporting material shall be submitted with the minor plat:
1. One application, on forms specified by the Commission.
 2. A list specifically citing any requirements of this Ordinance for which modifications are requested.
 3. The names and addresses of all interested parties as defined by this Ordinance, keyed to a map.
 4. A map showing all significant topographical and other physical features, including water bodies, existing buildings, alleys, streets, or other information that will aid in the location of the property for site visits.
 5. Evidence that a sewerage permit can be obtained from the Jackson County Health Department or evidence that other acceptable sewer and/or water service is available to all building lots in the subdivision.
 6. Documentation sufficient to show that all applicable design standards of this Ordinance are met by the proposed subdivision.
 7. Erosion control plan, if necessary to comply with the design standards of this Ordinance.
 8. Drainage plan, if necessary to comply with the design standards of this Ordinance.
 9. If there is a parent tract remainder, a drawing showing the property involved in the petition and the remainder. The drawing should include average and percentage dimensions on the AG remainder.
 10. Any covenants or other restrictions that will run with the land included in the subdivision.
 11. If any lot in a minor subdivision is to receive its access from a State highway, evidence that a driveway permit can be issued by the Indiana Department of Transportation shall be submitted.

3. Length of Approval -- Primary approval of a minor subdivision shall be valid for 120 days, unless the Plat Committee or Commission grants an extension. If secondary approval is not granted before the expiration of 120 days, the primary approval shall be null and void.

C. Secondary Approval

1. General -- After all conditions of primary approval have been met, the applicant may request secondary approval.
2. Required Submission Materials -- All requests for secondary approval shall be accompanied by the materials listed in this section, including an original drawing (which may be the same drawing submitted for primary approval) prepared in accordance with the standards set forth in this ordinance.
3. Supporting Material -- Documentation sufficient to show that all conditions of approval by the Commission have been met.
4. Length of Approval -- Secondary approval of a minor subdivision shall be valid for a period of one year from the date of such approval. If the subdivision is not recorded before the expiration of one year, it shall become null and void.

D. Minor Subdivision Review Process

1. Primary Approval by Plat Committee -- The Plan Commission hereby establishes a plat committee to review and decide petitions for minor subdivisions. The Plat Committee process is as follows:
 - a. Application and Fees -- The application and supporting materials shall be filed with the planning Building Commissioner. The fee as set by the commission shall be paid at the time of the filing.
 - b. Review -- The committee shall review the plat for compliance with the subdivision control ordinance.
 - c. Action -- Action by the Plat Committee shall be by a majority vote.
 - d. Public Notice -- Approval may be granted by the Plat Committee without public notice and hearing. Within ten (10) days after approval the applicant shall provide due notification by mail to adjacent property owners and the petitioners. Such notice shall include a notification of the right to appeal the committee's decision.

- e. Comment Period -- A notice of appeal must be filed with the Office of the Building Commissioner within ten (10) days after a copy of notice is mailed.
 - f. Appeals -- Appeals shall be governed as set forth in this ordinance.
 - g. Approval Certificate -- The Chairman and Secretary of the Plat Committee are authorized to sign the approval plat.
2. Primary Approval by Plan Commission – If the plat committee denies an application for a minor plat or the staff or committee refers the minor plat application to the plan commission, the following review process shall apply:
- a. Application -- An application for primary approval of a minor subdivision shall be filed at the Office of the Building Commissioner on forms specified by the Commission together with all required materials in accordance with the filing schedule.
 - b. Placement on Agenda -- Complete applications will be docketed for a public hearing before the Commission. The applicant will be notified of the time and place of the hearing.
 - c. Administrative Review -- Prior to the meeting, the Building Commissioner and the Subdivision Review Committee will review the application for compliance with this Ordinance. The Building Commissioner will send a copy of its written analysis of the proposal to the Commission and the applicant prior to the public hearing.
 - d. Field Trip -- The Commission and its representatives, at its discretion, and in compliance with Indiana's Open Door Law, may visit the site any time during the review process.
 - e. Public Hearing Notice -- The Commission shall hold a public hearing on the primary approval of the minor subdivision. At least 10 days before the hearing, notice of the hearing shall be in the local newspaper of general circulation and sent by mail to interested property owners as defined in the commission's rules.
 - f. Public Hearing -- At the public hearing, the request will be presented, and all those present will be given an opportunity to be heard regarding the proposal. The hearing may, at the discretion of the Commission, be continued to another date. Additional notice of a continued hearing is not required, but may be requested by the Commission.

- g. Decision by Commission -- After the public hearing has been concluded, the Commission will make a decision regarding the application. The Commission shall make findings of fact as to the compliance of the subdivision request with the terms of this Ordinance. The Commission may approve, approve with conditions, or deny the request. If the Commission denies the request, it shall make written findings that set forth its reasons.
 - i. If the Commission grants primary approval, two officers of the Commission shall sign the primary approval certificate.
 - ii. The Building Commissioner will provide the applicant a written record of the findings of the Commission and the Building Commissioner shall provide the applicant with a copy.

3. Secondary Approval Procedure

- a. Application -- After all conditions of primary approval have been met, the applicant may request secondary approval. An application for secondary approval shall be filed at the Office of the Building Commissioner on forms specified by the Commission together with any supporting documents required by the Commission to provide evidence that all conditions of primary approval have been met.
- b. Determination of Conformance -- The Building Commissioner will review the request for secondary approval and make a timely determination on its compliance with the primary approval and conditions.
- c. Changes After Primary Approval -- If a subdivision plat deviates in any way except for corrective details from the one receiving primary approval with the approved conditions, the subdivision will not receive secondary approval. Any changes in the approved plans must be submitted to the Commission or Plat Committee, unless such changes qualify as an exempt subdivision.
- d. Board of County Commissioners -- Subdivisions involving dedication of right-of-way to the public requires action by the County Commissioners.
- e. Signature and Seal -- After the Building Commissioner has determined that the secondary plat complies with the conditions of approval of the Commission and the County Commissioners have accepted any public dedications, improvements, and/or guarantees of performance, secondary approval shall be given by the

building commissioner and the Commission seal affixed to the secondary plat.

- f. Recording -- The secondary plat must be recorded in the County recorder's office prior to the expiration date or it will be null and void.

E. Amendment

If the applicant desires to make changes to a Minor Subdivision that has received Primary Approval from the Plat Committee, the applicant shall follow the same procedure as for the initial approval.

F. Appeal

A final decision of the Plat Committee including the imposition of conditions, may be appealed by the applicant or other interested party to the Plan Commission in accordance with the provisions of IC 36-7-4-700 *et seq.* or other applicable law or statute. In accordance with IC 36-7-4-708, any appeal must be filed in writing within 10 days after the notice of Plat Committee action is mailed to interested parties.

G. Recording

The approved drawing of the Minor Plat must be recorded in the Office of the Jackson County recorder within the time limit established in this ordinance, or the approval will be null and void.

V. Major Subdivisions

A. General

1. Purpose and Intent -- The purpose of the major subdivision procedure is to ensure that new development is consistent with the Comprehensive Plan and with the standards of this Ordinance, to ensure that new developments will have adequate roads, utilities and other infrastructure elements, and to ensure satisfactory completion of all required improvements. Major subdivisions require a public hearing, and Primary and Secondary Approval in accordance with the procedures set forth in the Jackson County Plan Commission Rules of Procedure.
2. Applicability -- Any subdivision that does not meet the requirements to be considered as an exempt or a minor subdivision shall be subject to the requirements applicable to major subdivisions.
3. Filing
 - a. The required concept plan shall be filed with the office of the building commissioner with any forms approved by the plan commission.
 - b. An application for Primary Approval of a Major Subdivision shall be filed with the office of the building commissioner on forms specified.
 - c. Applications for Major Subdivisions shall contain all required materials as specified in this ordinance.

B. Concept Plan

1. General -- Major subdivisions require primary approval by the Commission and secondary approval by the official designated in this Ordinance. Before filing a major subdivision, applicants are required to present conceptual plans for the subdivision to the Commission for approval. The plat committee shall review the concept plan and provide comments to the plan commission before the commission's discussion. Replats that require extension of streets or utilities shall be considered major subdivisions.
2. Concept Plan
 - a. Purpose -- In order to assist the applicant in preparing an acceptable major subdivision proposal, the Commission shall review and discuss with the applicant and/or his/her representatives a concept plan. The

purpose of this discussion is to enable the applicant to receive guidance from the Commission as to the suitability of the land for the development proposed and as to the pattern of development the Commission considers to be in the best interest of the County. The applicant may bring more than one alternative layout of lots and streets. Accurate surveys and detailed engineering data are not required nor recommended at this stage in the subdivision process.

- b. Required Submission Materials -- All applications for concept plan review shall be accompanied by the materials listed in this section:
 - i. Filing Fee -- Each concept plan submitted for review shall be accompanied by the required filing fee as established by the Commission.
 - ii. Concept Plan Contents -- The following materials shall be submitted for the Commission's review:
 1. Twelve copies of a legible map with an approximate scale no smaller than one inch equals 200 feet, with approximate 10-foot contours.
 2. Proposed name of the subdivision.
 3. North arrow and date
 4. Approximate site boundary
 5. Existing land use and zoning on the site and on the adjacent property, unless it is owned by the same owner, then go to an additional property.
 6. Existing traffic and circulation pattern.
 7. General soil classifications and existing drainage patterns.
 8. Any significant natural features of the site, such as streams, ponds, flood plains, wooded areas, or structures.
 9. Show existing utilities on-site and utilities that will be serving or surrounding the site within ½ mile – 300' from property line for water/sewer, show gas pipelines within ½ mile.
 10. Areas proposed for development, proposed uses, areas reserved for future development, and tentative street layout. This drawing shall show all contiguous holdings of the owner with an indication

of the portion that is proposed to be subdivided.

11. Areas reserved for open space, recreation, common areas, including centralized on-site sewer areas or retention areas.

- d. Commission Consideration -- Before providing guidance to the applicant regarding the proposed subdivision, the Commission shall give consideration to the following:
 - i. The arrangement, location, and width of streets in relation to the topography of the land, safety and ease of circulation, and relationship to neighboring property.
 - ii. Lot sizes and arrangement in relation to the topography and other characteristics of the land and in relation to neighboring property.
 - iii. Drainage, both on site and within the general area.
 - iv. Sewage disposal, water supply, and other utilities.
 - v. The relationship of the proposed subdivision to the zoning ordinance and the comprehensive plan.

4. Approval

- a. The concept plan approval shall be valid for a period of one year from the date of such approval. If the applicant fails to apply for primary approval before one year, said approval shall be null and void, and a new concept plan must be approved before primary approval can be given.
- b. After the recording of a secondary plat for any portion of the development, an approved concept plan shall not expire for a period of five years, unless an extension is granted. Modifications to the concept plan may be made only with approval from the Commission.

C. Primary Approval

1. Application -- After receiving the written record of the discussion of the concept plan, the applicant may request primary approval as specified in IC 36-7-4-703.

2. If the Commission approves development in phases under the terms of this ordinance, the primary plat may be for only the first phase of the subdivision.
3. Required Submission Materials -- An application for primary approval shall be accompanied by all materials specified in this section.
 - a. Filing fee as established by the Commission.
 - b. Primary Plat -- An applicant for primary approval shall submit a set of drawings conforming to the survey and drafting standards contained in this ordinance, except that scalar rather than computed dimensions may be shown and copies (with the number to be specified by the Commission) of the drawing(s) showing the following:
 - i. Legal description of the subdivision.
 - ii. Bar scale (the scale shall be 50 feet to the inch or larger, unless the property involved in the subdivision is of a size or shape which requires a smaller scale to fit on a 24" by 36" sheet size, in which case another scale approved by the Building Commissioner may be used).
 - iii. Lot numbers, scalar layout, dimensions, and sizes in square feet or acres.
 - iv. Accurate locations of all existing and platted streets intersecting the boundaries of the tract.
 - v. Existing property lines and interior deed lines, and source of the owner's title to the land as shown by the last entry in the records of the County recorder.
 - vi. All applicable certificates and notations as required by this ordinance.
 - vii. Accurate locations and dimensions of any property to be dedicated to the public or reserved for public, semi-public, or common use.
 - viii. Street rights-of-way as established by the Official Thoroughfare Plan of the County.
 - ix. Topographic contours at vertical intervals of five feet for areas containing land with 10 percent slope or greater, and at intervals of two (2) feet for areas containing land with less than 10 percent slope. The Topography may be shown on a separate print, but it shall be shown at the same scale as the original plat.
 - x. Delineation of flood plain boundaries, according to the official Federal Emergency Management

Agency's Federal Insurance Rate Map, indicating the classification of each flood plain area.

- xi. Location, size, elevation, and other appropriate description of all existing or proposed permanent features, either natural or man-made, including but not limited to streets, sewers, drains, water bodies, swamps or other wetlands, railroads, transmission towers, existing structures, County ditches, legal drains, water mains, culverts, utility lines, street lights, fire hydrants, drainage structures, and significant topographic features. Water elevations of adjoining lakes and streams at the date of the survey and the approximate high- and low water elevations. All elevations shall be referred to the U.S.G.S. datum plane.
 - xii. Location of pedestrian circulation system, if any, and the materials to be used for such system.
 - xiii. Delineation of the phases, if any, of the development, indicating the lots and improvements to be included in each phase.
- c. Supporting Material. An applicant for primary approval shall submit the following supporting material with the primary plat:
- i. One application, on forms specified by the Commission.
 - ii. Proof of notification of all interested parties as defined by this Ordinance.
 - iii. Preliminary erosion control plan
 - iv. Preliminary sewage disposal plan
 - v. Preliminary Drainage plan and report.
 - vi. Copies of all restrictions and/or covenants that will run with the land.
 - vii. Zoning classifications of the property included in the subdivision and on adjacent parcels.
 - viii. Preliminary plans for any required improvements to existing County roads.
 - ix. For any improvements or systems which are to be owned and/or maintained by the property owners in the subdivision, a plan for establishing such ownership and for providing and financing such maintenance. Documents and/or plans submitted under this section are

See Chapter VII, Development and Design Standards for more information regarding Jackson County's standards, including typical sections.

subject to determination by the Commission that they are adequate to ensure that the County will not be held responsible in the future for such maintenance.

d. Sewage system approval

- i. If the development is to contain individual on-site sewage disposal systems, the applicant must show that the design criteria in this ordinance are met, and in addition, the applicant must provide for each lot a certificate from the County Health Department indicating that either a reparable mound system or two such subsurface systems can be installed on the property and detailing any conditions to be placed upon such installation. The Commission may require these conditions to be recorded as part of the approved subdivision
- ii. If the development is to be served by a public or semi-public sewer system, the applicant must provide evidence that such system has the capacity and capability to serve the development and guarantees of a sufficient number of hook-ons to serve all lots in the subdivision.
- iii. If the development is to be served by a private system, the applicant must provide a plan that shows that there are arrangements to ensure continued operation and maintenance of the system.

- e. A list specifically citing any requirements of this Ordinance for which modifications are requested and the reasons for such request.
- f. Documentation sufficient to show that all design standards as set forth in this ordinance are met.

5. Approval – A major subdivision may receive primary approval as submitted or approved with conditions as directed by plan commission. Approval shall be valid for a period of one year from the date of such approval. If the applicant fails to apply for final approval before the expiration of one year said approval shall be null and void.

If the Commission approves development in phases, after the approval of the secondary for any phase of the development, the primary approval shall not expire for a period of three

An example of a public system would be the City of Seymour's utilities.

years. Modifications to the primary plat may be made only with approval from the Commission.

D. Secondary Approval

After all conditions of primary approval have been met, a secondary plat that meets such conditions may be submitted for secondary approval.

1. Required Submission Materials -- An application for secondary approval shall be accompanied by all materials specified in this section.
 - a. Secondary plat -- An applicant for secondary approval shall submit original drawings prepared by a registered land surveyor in accordance with the standards set forth in this ordinance, and copies (with the number to be specified by the Commission) showing all information listed above (with computed lot dimensions, and sizes), in accordance with the Commission's approval.
 - b. Final Improvement Plans -- An applicant for secondary approval shall submit drawings detailing all improvements to be installed as approved by the Commission. These drawings shall contain all applicable notations and certificates as specified in this ordinance.
 - c. Supporting Material -- An applicant for secondary approval shall provide documentation sufficient to show that all conditions of approval by the Commission have been met.
2. Length of Approval -- Secondary approval shall be valid for eighteen months from the date of such approval.
3. Extensions -- The Commission may grant a maximum of 3 extensions of time, with each extension not to exceed 18 months, only if the applicant demonstrates to the Commission's satisfaction that there are extenuating circumstances that necessitate or justify the extension. The applicant must request such extension before the expiration of the approval period.

E. Major Subdivision Approval Process

This section applies to any subdivision that is deemed to be a major subdivision under the terms of this Ordinance.

1. Concept Plan Procedure
 - a. Application. An application for concept plan consideration shall be filed on forms specified by

the Commission together with all required materials in accordance with the filing schedule.

- b. Placement on the Commission Agenda -- Complete applications will be docketed for consideration by the Commission. The applicant will be notified of the time and place of the meeting at which the concept plan will be discussed.
- c. Administrative Review -- Prior to the Commission meeting, the Office of the Building Commissioner will review the concept plan. Comments on the plan may be requested by the Building Commissioner from the Subdivision Review Committee and by such other persons as the Commission deems appropriate.
- d. Public Meeting -- The Commission shall review the proposed concept plan at a public meeting. The Building Commissioner will present comments on the plan to the Commission. The Commission will discuss the plan and provide guidance to the applicant as to the suitability of the land for subdivision and the design and layout of lots and improvements.
- e. Commission Action -- The Commission shall by a motion duly made and seconded approve, deny, or continue the concept plan. Approvals may be conditioned upon design changes. Any Motion to continue must include guidance to the applicant as to the type(s) of information and/or changes the Commission requires in order to arrive at a decision. Any motion to deny must include reasons for the denial. The approved concept plan shall contain the signature of the presiding officer of the Commission and shall be kept on file at the Office of the Building Commissioner.
- f. Written Record -- The Commission will provide a written record to the applicant on the discussion within 30 days after the meeting(s) at which the concept plan is discussed.

2. Primary Approval Procedure

- a. Application -- After receiving the written record of the discussion of the concept plan, the applicant may request primary approval. An application for primary approval shall be filed at the Office of the Building Commissioner on forms specified by the

- Building Commissioner together with all required materials in accordance with filing schedule.
- b. Placement on Commission Agenda -- Complete applications for the primary approval will be docketed for a public hearing before the Commission. The applicant will be notified of the time and place of the hearing.
 - c. Administrative Review -- Prior to meeting, the Building Commissioner and the Subdivision Review Committee will review the application for compliance with this Ordinance. The Building Commissioner will send a copy of the written analysis of the proposal to the Commission and applicant prior to the public hearing.
 - d. Field Trip -- The Commission and its representatives, at its discretion, and in accordance with Indiana's Open Door Law, may visit the site any time during the review process.
 - e. Public Hearing Notification -- Within 30 days after receiving the application, the Building Commissioner shall announce the date of a public hearing before the Commission. At least 10 days before the hearing, notice of the hearing shall be published in accordance with IC 5-3-1 and sent by the applicant in the manner specified by the Commission's Rules of Procedure to interested property owners as defined in this Ordinance.
 - f. Public Hearing -- At the public hearing, the request will be presented, and all those present will make a decision regarding the application. The hearing may, at the discretion of the Commission, be continued to another date. Additional notice of a continued hearing is not required, but may be requested by the Commission.
 - g. Decision by Commission -- After the public hearing has been concluded, the Commission will make a decision regarding the application. The Commission shall make findings of fact as to the compliance of the subdivision request with the terms of this Ordinance. The Commission may approve, approve with conditions, or deny the request. If the Commission disapproves the subdivision, it shall make written findings that set forth its reason, the Building Commissioner shall sign the decision, and the Building Commissioner shall provide the applicant with a copy.

to the secondary plat, and the Building Official shall sign the improvement plans.

- g. Recording -- The secondary plat must be recorded in the County Recorder's office prior to the expiration date or it will be null and void.

F. Phases

1. The Commission may allow a subdivision to be developed in phases. The applicant shall request phasing at the time of filing for Primary Approval. If the Commission approves the development to be completed in phases, Secondary Approval of each phase shall automatically extend deadline for Secondary Approval of subsequent phases for an additional 3 years.
2. In reviewing a request for phased development, the Commission shall consider the factors listed in this section:
 - a. Design Standards -- The relationship of the number and configuration of the lots in each phase shall conform to the design standards of this Ordinance.
 - b. Improvements -- The improvements in each phase shall be adequate to serve the lots to be developed in that phase. In no case shall the Commission approve a phasing plan in which any phase is dependent upon improvements proposed to be made in a future phase.
 - c. Non-Completion of Subdivision -- The Commission shall attempt to ensure that each phase of the subdivision will conform to the intent and purposes of this Ordinance in the event that some phases are not completed.

G. Recording

The approved drawing of the Secondary plat must be recorded in the Office of the Jackson County Recorder within the time limit established in this ordinance, or the approval will be null and void.

VI Conservation Subdivisions

A. Purpose

This Conservation Subdivision ordinance is intended to encourage environmentally sound planning to protect open space and natural resources, and create attractive living environments, and through creative placement of dwelling units, discourage consumption of scenic, forested, agricultural, and recreational land for development, thus maintaining the rural character of Jackson County and advancing the goals stated in the Comprehensive Plan.

B. Objectives

1. To maintain rural character, preserving farmland, forests and maintaining rural views.
2. To preserve those areas of the site with the highest value for conservation purposes.
3. To locate buildings and structures on those portions of the site that are the most appropriate for development considering both the development suitability of the site and its conservation value.
4. To preserve identified historic, known archeological and identified cultural features located on the site.
5. To create contiguous network of open spaces or “greenways” by linking the common open spaces within the subdivision and to open space on adjoining lands wherever possible.
6. To reduce the impacts on water resources by minimizing land disturbance and the creation of impervious surfaces and runoff.
7. To reduce the amount of roads, sidewalks, and stormwater management structures that must be built and maintained.
8. To minimize the impact of residential development on the neighboring properties and the natural environment.

C. Authority and Applicability

Use of Conservation Subdivision Design – Applicants may request permission from the Plan Commission to use a Conservation Subdivision Design approach.

D. Maximum Development Density and Dimensional Requirements

1. Base Number of Development Units: The applicant shall use the following method for calculating the maximum number of dwelling units that may be constructed on the property:

Base Number of Development Units
Example: The base number of development units for a 120-acre parcel in a zone with a minimum 3-acre lot size, having 30 acres of wetlands would be 30 units:
[(120 acre site – 30 acres of wetlands) the buildable area + (30 acres wetlands * 1/3) the non-buildable area] * 0.9] / 3-acre lot size = 30 the base number of development units]

1) The base number of dwelling units may be determined by taking ninety percent (90%) of the sum of the calculated buildable area and one-third (1/3) of the non-buildable area of the parcel, and dividing by the required minimum lot size per dwelling unit under the conventional zoning standard for the parcel, and rounding to the closest whole number. If more than fifty percent (50%) of the parcel is made up of non-buildable area, then none of the nonbuildable land shall be counted in calculating the base number of dwelling units. If the subdivision involves only part of a parcel, the Buildable Area shall be calculated for that portion of the parcel proposed to be included in the subdivision. If a parcel is located in more than one district, the base number of allowable dwelling units will be determined for each portion of the parcel separately and added together and then rounded to the next whole number.

2. Incentives

Additional dwelling units and/or lots, not to exceed fifteen percent (15%) over and above the base number of dwelling units or permitted lots, may be awarded at the discretion of the Plan Commission for any of the following:

- a. Conservation of greater than fifty percent (50%) of the parcel as designated open space shall receive a five (5%) percent increase in the allowable number of dwelling units for every additional ten percent (10%) of open space protected, up to fifteen (15%) percent total increase;
- b. Developments that grant increased access to the designated open space, including access to active recreation areas and/or facilities, to the general public or to all residents of the county, not just the residents of the conservation subdivision itself, shall be eligible for a ten (10%) percent increase in the number of allowable dwelling units.
- c. Developments that provide for a conservation easement, acceptable to the Plan Commission and held by the county or recognized conservation organization or land trust shall be eligible for a ten (10%) percent increase in the number of allowable dwelling units.

3. Lots in a Conservation Subdivision

- a. Residences in a Conservation Subdivision shall be located on individual residential lots.
- b. Individual Lot Sizes:
 1. If public wastewater treatment is not available, individual lots, if created, shall be based on soil-based lot sizing requirements for wastewater management under a cluster subdivision using an individual, joint, or community

Why this formula?

Using only 90% of acreage accounts for the approximate 10% that would be allocated to streets under a conventional subdivision design, and therefore not available when laying out individual lots.

Including some portion of the nonbuildable area in the calculation of the base number of allowable units when less than 50% of the parcel is considered "non-buildable," recognizes that under a conventional subdivision plan, some amount of non-buildable land (like floodway) may be included when delineating a conventional lot.

Not including non-buildable land when it represents more than 50% of the parcel area discourages the development of parcels using conservation design when they would have been unlikely to develop as a conventional subdivision.

Incentives Example:

A 20-unit development with 72% of the parcel area retained as designated open space would receive 2 additional bonus units, for a total of 22 units.

septic and an individual, joint or community well. All lots shall comply with the Indiana State Board of Health's design requirements for subsurface wastewater treatment systems.

2. Lot sizes may be larger than the minimum required under soil-based lot sizing to comply with other requirements of this section, particularly the dimensional and design standards of this section, or applicable aspects of the underlying zoning for the parcel to protect human health, welfare and public safety.

3. If public wastewater treatment is available, individual lots, if created, shall be the minimum size necessary to comply with the dimensional and design requirements of this section, and the underlying zoning for the parcel. In no case, shall an individual lot be less than 5,000 square feet.

4. The size of the individual lots shall be shown on the subdivision plan and shall be subject to Plan Commission approval based upon its finding that the lot sizes will allow for the creation of a high-quality living environment for the residents of the subdivision and the abutting property owners.

4. Dimensional and Technical Specifications for Individual Lots

If individual lots are created as part of a Conservation Subdivision, the lots shall conform to the following requirements:

a. Lots that have frontage on an existing public road shall be laid out to minimize the number of curb cuts onto the existing road through the use of shared or common driveways or other methods. The number of curb cuts and distance between them shall be subject to Plan Commission approval.

b. Building envelopes shall be specified for each lot indicating the location of any future land disturbance and structures that may be placed on the lot.

c. Lots and building envelopes for each new lot shall ensure an adequate separation between new primary structures and between new primary structures and existing structures on adjacent lots according to the scale below. The distance of separation between new and existing structures generally shall be greater than or equal to the average distance of separation between existing structures on adjacent parcels (if those parcels are developed as residential subdivisions). Variations from this standard may be granted by the Plan Commission as a modification provided that the intent of this section is met.

d. In all cases, the separation distance between principal buildings within the subdivision, whether on the same lot or on different lots, shall conform to the requirements of the County's zoning

Zoning Minimum Lot Sizes:

See the Jackson County Zoning Ordinance for more information on lot sizes for conservation subdivisions.

Separation Distance Between Structures:

Relying on separation distances between structures instead of lot frontage and building setback requirements allows for maximum flexibility in the design and layout of a conservation subdivision, maximizing the potential protection of open space. Instead of these traditional zoning standards, distance

Typical Conservation Subdivision Separation Distances Between Structures:

- 4 or more acres per lot or 300' ft frontage = 250'
- 2-3 acres per lot or 250' ft frontage = 150'
- 1 acre per lot or 200' frontage = 100'
- <1 acre per lot = separation based on characteristics of adjacent development

- ordinance, building code and fire protection codes based upon the type of construction and the use of the buildings.
- e. Height limits for structures shall be determined by the underlying zoning for the parcel.
 - f. Building envelopes shall provide for a minimum setback per the zoning ordinance requirements.
 - g. Building envelopes shall be delineated to ensure that no structures shall be less than 20 feet from the edge of pavement of the roadway. Variations from this standard may be allowed by the Plan Commission, provided that public safety is maintained.
 - h. The setback of building envelopes and structures from the roadway shall vary from lot to lot within the subdivision to retain significant, natural vegetation along the roadway; provide increased privacy for residents on adjacent lots; and increase the visual variety provided by the arrangement of homes within the subdivision.
 - i. Shared driveways are permitted and encouraged where appropriate to access individual lots. In no case shall more than three (3) dwelling units share a single driveway. Shared driveways shall be no longer than 500 feet in length.
 - j. Individual lots may be irregular in shape.
 - k. A septic leach field may be located outside of the lot line boundaries provided the requirements of the Indiana Department of Health are met, including appropriate legal provisions to allow for maintenance and replacement. Individual leach fields may be located in a designated open space area provided the conservation area is owned by that individual, or owned by the town or a third-party conservation organization that accepts a legal utility easement to permit the leach field.
 - l. Specifications of individual lot lines, access, setbacks and the location of building envelopes on individual lots shall be subject to Plan Commission approval based upon its finding that the subdivision layout will allow for the creation of a high quality living environment for the residents of the subdivision and provide for adequate privacy and public safety.
 - m. Garages and secondary structures shall be placed at least 5 feet behind the front of the main structure from the roadway, and preferably shall be located behind the main structure. Garages not located behind the main structure shall be side-entry such that the bay doors shall not face the roadway.
 - n. Lots shall be developed in small groups or pods, including no more than six (6) lots developed contiguously, with pods separated by a minimum of 100 feet of retained, pre-existing, mature vegetation. If existing, mature vegetation is lacking on the site, the 100-foot separation area shall be replanted with a substantial number of trees and shrubs to provide a visual break between the

Clustering House Lots in Pods:
The restriction on the number of house lots that may be clustered together in a contiguous grouping or “pod” is intended to provide for natural visual breaks in the developed area of the parcel, resulting in a more rural appearance than tightly clustering a large number of homes in an area.

Pods. The Plan Commission may increase the number of homes per grouping or pod provided that the intent and design standards of this section are met.

E. Open Space Requirements

1. At least fifty percent (50%) of the parcel's buildable area, plus at least eighty percent (80%) of the unbuildable area, shall be permanently protected as open space (designated open space) subject to the additional restrictions below and as approved by the Plan Commission.
2. Protection of greater than fifty percent (50%) of the parcel's buildable area and/or greater than eighty percent (80%) of the unbuildable area shall be encouraged when a parcel is larger than 100 acres in size or contains a predominance of desirable conservation features as identified in this ordinance.
3. The Plan Commission may allow as little as forty percent (40%) of the parcel's buildable area and as little as fifty percent (50%) of the unbuildable area to be set aside as permanently protected open space when required to enable the use of the conservation subdivision approach based on the unique characteristics of the parcel and provided that the proposed subdivision adequately meets all other requirements of this ordinance.
4. Portions of the parcel that comprise part of an individual house lot, roadway, driveways, access roads, roadway right-of-way, utility easements, or other new or existing rights-of-way, shall not count toward the calculation of the designated open space.
5. Areas containing the following shall be considered high priority for inclusion in the designated open space:
 - a. Riparian areas and other water resource buffers;
 - b. High quality forest resources;
 - c. Critical or high-quality habitat areas and buffers to these areas;
 - d. High-quality soil resources (forest or agricultural soils);
 - e. Cultural and historic resources (e.g., stone walls);
 - f. Existing trails;
 - g. Areas that connect to protected open space on adjacent properties;
 - h. Ridgelines that continue through the parcel;
 - i. View shed areas.
6. Generally the use of the open space shall conform to the following standards, unless the plan commission determines otherwise:
 - a. All uses of open space are prohibited if an area to be conserved contains critical wildlife habitat.

- b. Only passive recreation, agriculture and forestry are permitted in a development in a rural agricultural area.
 - c. Intensive recreation (i.e., ball fields or tennis courts) are permitted on some portion of the designated open space if a conservation subdivision is near an incorporated area.
7. The following uses are permitted in the designated open space, unless specifically prohibited or restricted as a condition of subdivision approval for the purposes of protecting critical wildlife habitat or a public drinking water supply:
 - a. forest management;
 - b. agricultural cultivation;
 - c. passive (non-motorized) trails and recreational uses.
8. Up to fifteen percent (15%) of the designated open space may be used for the following, unless such uses are specifically prohibited as a condition of the subdivision approval:
 - a. agriculture involving animal husbandry, but not including confined feeding operations;
 - b. active outdoor recreation uses, including formal playgrounds and fields;
 - c. parking areas for access to the designated open space;
 - d. Support facilities necessary for the subdivision including community wells, community leach fields, stormwater management facilities, underground utility lines and related facilities such as sewer pump stations;
 - e. Individual or group wells and/or underground wastewater disposal systems or parts thereof, provided that this use was approved as part of the subdivision plan and that appropriate legal arrangements are established and approved by the Plan Commission for the maintenance and operation of these facilities;
9. The following uses are permitted on up to fifty percent (50%) of the designated open space if allowed by the Plan Commission:
 - a. agriculture involving animal husbandry, but not including confined feeding operations;
 - b. active outdoor recreation uses;
 - c. facilities, including parking, provided that any building shall have a gross floor area of less than 200 square feet and the total gross floor areas of all such buildings shall be less than 1000 square feet;
 - d. Indoor community or recreational facilities that primarily serve residents of the subdivision, have a total gross floor area for all such facilities of less than 2000 square feet, and are compatible with the overall scale and character of the subdivision;

- e. small community storage buildings, and similar buildings and structures that are needed for the operation of the subdivision but not including personal storage buildings or sheds;
 - f. Support facilities necessary for the subdivision including community wells, community leach fields, stormwater management facilities, underground utility lines and related facilities such as sewer pump stations;
 - g. Individual or group wells and/or underground wastewater disposal systems or parts thereof, provided that this use was approved as part of the subdivision plan and that appropriate legal arrangements are established and approved by the Plan Commission for the maintenance and operation of these facilities;
10. No more than five percent (5%) of the designated open space shall be covered by impervious cover.
 11. The designated open space shall not be used as the location for dwelling units, roadways, other access, private recreation structures or play equipment, private accessory structures, or other nonresidential buildings or parking except as provided above.
 12. The designated open space shall not be disturbed during construction, except in areas identified for permitted uses as provided above. Boundaries shall be marked and temporary fencing installed to prevent disturbance.
 13. The removal of soil, trees, and other natural features from the designated open space is prohibited, except as consistent with conservation objectives or permitted uses as provided above.
 14. The designated open space shall be retained in a natural, undisturbed state, except for those activities permitted as provided above.

F. Protection and Management of Open Space

1. Area Boundaries of the Designated Open Space shall be clearly identified:
 - a. Boundaries shall be clearly delineated on plans including plats;
 - b. Boundaries shall be clearly marked prior to commencing construction activities (temporary markings are acceptable);
 - c. Boundaries shall be clearly, and permanently marked in the field with signage approved by the Plan Commission to identify the area as protected open space.

2. Development in and/or subdivision of Designated Open Space areas in the future shall be prohibited and shall be so noted on the approved subdivision plan/plat.
3. Prior to the sale of any lots, the Designated Open Space shall be protected and controlled by one or more of the following methods subject to Plan Commission approval:
 - a. Dedicated to the county or an adjacent municipality as open space, with public access and permanent deed restriction or conservation easement in place;
 - b. Transfer, with permanent deed restrictions or conservation easement, to a land trust or other recognized conservation organization (subject to acceptance by the organization);
 - c. For Designated Open Space areas of less than 50 acres, ownership by one or more private individuals (separately or in common) or by an association of the owners of the dwelling units within the subdivision (i.e., homeowner's association) with open space protection deed restrictions enforceable by any land owner within the association, any owner of separate land parcels adjacent to the open space, or the county;
or
 - d. Ownership by one or more private individuals (separately or in common) or by an association of the owners of the dwelling units within the subdivision (i.e., homeowner's association) with a conservation easement granted to the county and/or recognized conservation or land trust organization.
4. Said deed restrictions and/or conservation easement documents shall be placed on file with the Plan Commission upon receipt of Plan Commission subdivision approval and duly recorded at the County Recorder's Office, in conjunction with the approved plat. Such documents shall clearly indicate whether the property is open to the general public or open only to residents of the subdivision.
5. A management plan for the Designated Open Space and facilities shall be prepared and approved by the Plan Commission, subject to the following:
 - a. Identifies the entity assuming responsibility for stewardship and management of the designated open space, including regular inspections to confirm continued compliance with the terms of the subdivision approval and conservation easement or deed restrictions;

- b. Includes detailed standards and schedules for maintenance of the Designated Open Space, including maintenance of vegetation;
 - c. Allows for county maintenance, subject to tax lien against the owners of the open space, in the event that the maintenance specified under the agreement is not completed; and
 - d. Provides that any amendments to the plan shall be reviewed and approved by the Plan Commission.
6. For properties containing open space protected under a conservation easement to be held and enforced by the county or a third-party, a stewardship fee shall be collected and provided to the third-party to be held in a separate trust account and used to support the monitoring and enforcement of the conservation restrictions. The amount of the stewardship fee shall be determined based on the size and restrictions in place on the open space and the requirements of the third-party easement holder.
7. All documents, including deed restriction language, conservation easements, and the management plan shall be reviewed and approved by the Plan Commission's Attorney prior to receiving subdivision approval from the Plan Commission.

G. Design Standards

The following design standards are intended to improve the character and aesthetic qualities of the development and to minimize its impact on the environment. Variations from these standards may be granted by the Plan Commission provided that the overall intent of this section is achieved by the alternative design.

1. The landscape shall be preserved in its natural state, insofar as practical, by minimizing tree and soil removal. Not including the right-of-way for any access roadway, no more than 20,000 square feet of contiguous area shall be cleared for individual lot development.
2. Any grade changes shall be in keeping with the general appearance of the neighboring developed areas. Cut and fill shall be limited to 10 feet, and preferably less than 6 feet.
3. The orientation of individual building envelopes shall be such as to maintain maximum natural topography and cover, make use of passive solar energy for lighting and heat, and minimize disturbance to the landscape.
4. Building envelopes shall not be located on ridges, hilltops, along peripheral public roads, or in other visually prominent areas.

5. Topography, tree cover, and natural drainage ways shall be treated as fixed determinants of road and lot configuration rather than as malleable elements that can be changed to allow for a preferred development scheme.
6. The Plan Commission shall encourage design that reduces the amount of impervious cover created and reduces the amount of stormwater runoff generated, and supports the use of stormwater management approaches that retain and infiltrate rainwater onsite in small treatment areas dispersed throughout the development.
7. Streets and driveways shall be designed and located in such a manner as to maintain and preserve natural topography, significant landmarks, and trees; to minimize cut and fill; to minimize impacts to wildlife passage; and to preserve and enhance views and vistas on or off the subject parcel.
8. Streets shall be curved to follow the natural topography with no straight segment extending more than 300 feet.
9. Streets shall be the minimum width and length necessary to meet traffic demands and allow emergency vehicles passage, following the recommendations provided by “Guidelines for Geometric Design of Very Low-Volume Local Roads” by the American Association of State Highway and Transportation Officials (AASHTO).
10. Stream and wetland crossings shall be eliminated whenever possible. When necessary, stream and wetland crossings shall be design to facilitate animal passage and accommodate high-volume flows of water.
11. Any portion of the designated open space not retained in its natural condition (e.g., landscaped parks, areas put toward active recreation) shall be designed to add to the visual amenities of the area by maximizing the viewscape for persons passing the site or overlooking it from nearby properties. If open space is used as parks or recreation facilities, it should provide easy access to all allowable users.
12. On-Site Pedestrian and Bicycle Circulation: Sidewalks and/or trails shall be provided to link residences with parking areas, recreation facilities (including parkland and open space) and adjacent land uses where appropriate.
13. Other design requirements that apply to all residential subdivisions shall continue to apply. These may include, but are not limited to, landscaping standards, street and neighborhood lighting provisions, utility placement, erosion and sediment control, and post-construction stormwater management.

***Why Limit
Straight Streets?***

The requirement prohibiting long stretches of straight roadway is intended to help preserve rural character by minimizing the visual impact of seeing a large number of homes clustered in a view.

H. Pre-application Meeting Required

A pre-application site inventory review meeting and preliminary conceptual plan review meeting are required by all applicants for conservation subdivisions prior to submitting a formal application. Applicants shall submit information and plans, as required by the Plan Commission, to facilitate and support the conceptual design discussion and conceptual plan review meetings.

I. Subdivision Application Requirements and Review Process

1. **Site Inventory Review and Conceptual Plan Discussion.** To facilitate discussion of the conceptual design of the Conservation Subdivision plan at the pre-application, conceptual design review stage, applicants shall submit the following information:
 - a. Site Context Map or Location Map – This map enables the Plan Commission to understand the site in relation to what is occurring on adjacent properties and surrounding area. It should be drawn at a size adequate to show the relationship of the proposed subdivision to the adjacent properties and to locate the subdivision within the municipality. The site context map shall be based upon existing data sources and field inspections and shall include the following:
 - i. Existing subdivisions in the proximity of the proposed subdivision, including building locations;
 - ii. Locations and names of existing streets;
 - iii. Boundaries and designations of zoning districts;
 - iv. An outline of the subject parcel and the proposed subdivision and any remaining portion of the owner’s property if the subdivision will only cover a portion of the owner’s entire contiguous holding.
 - b. Site Inventory Map and Analysis – The Site Inventory Map familiarizes officials with existing conditions on the property. Based upon existing data sources and field inspections, this base map locates and describes noteworthy resources that should be considered through sensitive subdivision layout. This map shall be at a scale of not more than fifty (50) feet to the inch and include, at a minimum, the following:
 - i. The proposed name of the subdivision, north arrow (True Meridian), date, and scale;
 - ii. The boundaries of the parcel based upon a standard boundary survey prepared by a

- registered land surveyor and giving the bearings and distances of all property lines;
- iii. Existing structures or easements on the site (if none, so state);
 - iv. The topography of the site at an appropriate contour interval depending on the nature of the use and the character of the site;
 - v. The major natural features of the site and within five hundred (500) feet of the site, including wetlands, vernal pools, streams, ponds, rivers, natural swales and drainage ways, riparian areas, floodplains, significant wildlife habitats, boundary trees, wooded areas, scenic views or areas, significant geologic features, ridgelines, slopes in excess of twenty-five (25) percent, escarpments, prime agricultural soils, and any other important natural features. Wetlands on the site shall be identified and delineated and shall be certified by the person performing the delineation. Information on adjacent properties may be from published sources.
 - vi. The major anthropogenic features of the site and within five hundred (500) feet of the site, including historic or cultural features, stone walls, roads, driveways, fences, trails, historic structures or remnants, archeological resources, graveyards, cemeteries, views onto and off of the site, and any other important features (if none, so state).
 - vii. Identify severe soil conditions, based on the soil survey.
 - viii. Vegetative cover and its condition;
 - ix. Location and size of existing utilities or improvements to the site (if none, so state);
 - x. If not served by public water, any potential sources of fire protection water supply within one half mile of the site, including public water mains, existing fire ponds, or other possible sources.
 - xi. Preliminary identification of those areas of the site deemed suitable for development or use and those areas with the most significant conservation value based on the assessment of the site.
- c. Site Visit – Applicants are encouraged to allow a site visit by Plan Commission members and staff to

facilitate pre-application review of the Site Inventory Map and Conceptual Conservation Subdivision Plan.

2. **Preliminary Conceptual Plan Review.** The Concept Plan is intended to be a draft of the proposed design for the subject subdivision. To ensure maximum opportunity to revise the proposed design based on Plan Commission and public input, the concept plan should not be a fully-engineered plan.
 - a. To facilitate review and discussion, the Concept Plan shall include the following:
 - i. The subdivision name, boundaries, north point, date, legend, title “Concept Plan” and scale.
 - ii. The names of the record owner and the applicant, and the name of the person that prepared the plan.
 - iii. The names, approximate location, and widths of adjacent streets.
 - iv. The proposed topography of the land shown at a contour interval no greater than 4 feet. Elevations shall be referred to mean sea level.
 - v. The location of existing landscape features including forests, farm fields, meadows, wetlands, riverfront areas, water bodies, archeological and historic structures or points of interest, noteworthy tree specimens, and habitats of endangered or threatened wildlife as identified as primary and secondary resources. Proposals for all site features to be preserved, demolished, or moved shall be noted in this plan.
 - vi. All on-site local, state, and federal regulatory resource boundaries and buffer zones shall be clearly identified.
 - vii. Lines showing proposed private residential lots with approximate areas and dimensions and a proposed building envelope indicating the expected location of any land disturbance activity and structures.
 - viii. All existing and proposed features and amenities including trails, recreation areas, pedestrian and bicycle paths, community buildings, off-street parking areas (and any others) shall be shown on the plan and described in a brief narrative explanation where appropriate.
 - ix. The existing and proposed lines of streets, ways, common driveways, easements, and any parcel of land intended to be dedicated for public use

or to be reserved by deed covenant for use of all property owners in the subdivision, or parcels of land or lots to be used for any purpose other than private residential shall be so designated within the subdivision in a general manner.

- x. Narrative description of the streets.
 - xii. A narrative explanation detailing the proposed wastewater systems that will be utilized by the development and its likely impacts on-site and to any abutting parcels of land.
 - xiii. A narrative explanation of the proposed stormwater management approach and its likely impacts on-site and to any abutting parcels of land. The approximate location of any stormwater management facilities shall be shown on the plan and accompanied by a conceptual landscaping plan.
 - xiv. A narrative explanation detailing the proposed drinking water supply system.
 - xv. A narrative explanation of the proposed quality, quantity, use and ownership of the open space. Proposed conservation areas shall be clearly shown on the plan.
 - xvi. A list of all legal documents necessary for implementation of the proposed development, including any Conservation Restrictions, land transfers, and Master Deeds, with an accompanying narrative explaining their general purpose.
3. Conceptual Long Range Development Plan -- When a subdivision will not utilize the entire parcel and there is potential for future subdivision or development of the parcel or any of the lots being created, the application for subdivision approval shall include a Conceptual Long Range Development Plan showing the potential utilization of the lots and the balance of the parcel not being subdivided. The Long Range Plan is intended to be conceptual in nature, to rely on published data about natural resources relevant to the parcel and the built environment, and to demonstrate that the current subdivision proposal will not compromise important conservation values or the long term development of the parcel as a Conservation Subdivision. This plan shall show the relationship of the proposed subdivision area to the balance of the parcel and to adjacent land. This plan shall analyze the conservation and development potential of the remaining area of the parcel and shall show, in general terms, the potential street network, open

space areas, and development areas in a manner that demonstrates that both the proposed development and the future development can occur so that it conforms to the requirements for Conservation Subdivisions and preserves the significant natural resource and conservation values of the entire parcel.

J. Subdivision Application

A formal application for a residential subdivision shall include copies of the site context map, site inventory, and conceptual plan as previously submitted to the Plan Commission.

Because of the permanently protected open space, the subdivision application shall include the following:

1. Preliminary Open Space Ownership and Stewardship Plan, including, but not limited to:
 - a. A description of all common open space and any other lands and facilities proposed to be owned by the Town, conservation organization, homeowner's association, or individual land owners, that will be protected under conservation easement, held by a third-party, or deed restrictions.
 - b. A map of the land to be conserved showing the location of any facilities or structures.
 - c. A description of the proposed ownership arrangements for the land to be conserved.
 - d. A description of the proposed conservation easement or deed restrictions that will permanently protect the portions of the parcel to remain undeveloped.
 - e. A description of the proposed arrangements for long-term stewardship of the common open space including management objectives and techniques for the property, identification of the organization having primary and secondary responsibility for conducting regular monitoring of the property and if necessary, enforcing the terms of the easement, a list of the allowable uses for the protected open space indicating any restrictions, and the proposed fee to cover the long-term stewardship of the property.
 - f. Copies of proposed deed restrictions, conservation easements, and stewardship/management plan for the open space conservation area, and other legal documents relating to the ownership, protection, and stewardship of the conserved land.

- g. Evidence that a governmental body, homeowner's association, or independent third party will be designated to assure compliance with all conservation restrictions and is willing to assume this responsibility, including establishing a Stewardship account to support future oversight.
- 2. Clear delineation of the area to be conserved as part of the conservation design subdivision and demonstrate that the subdivision layout meets the following:
 - a. At least 75% of the open space conservation area is contiguous with other open space;
 - b. No portion of the open space conservation area is less than 100 feet wide;
 - c. The area designated as open space conservation area is contiguous with existing undeveloped, open space on adjacent parcels;
 - d. The open space conservation area includes and protects, to the maximum extent possible, the desired natural and cultural features of the parcel identified in the site inventory map.

VII. Development & Design Standards

A. Minor Subdivisions

1. General Requirements: The subdivision plan shall conform to the principles and standards which are generally exhibited in the Jackson County Comprehensive Plan, adopted September 19, 2006; and any amendments thereto.
2. Lots
 - a. The requirements of this section apply to lots which are intended to be used for private building sites. These requirements may not apply to common areas intended for open space, drainage detention, recreation, or other reasons.
 - b. Each lot shall provide a suitable building site large enough for the principal structure, on-site sewage and water systems (if applicable) and customary accessory structures. Features such as steep grades, flood zones, wetlands, poor soils, and environmental restrictions should be identified to show that adequate suitable space is available on each lot.
 - c. All lots shall abut on an existing public street or approved access easement with minimum frontage as required by the zoning ordinance.
 - d. Side lines of lots shall be at approximately right angles to tangent street sections and on radial lines along curved streets. Pointed or very irregular lots should be avoided.
 - e. Widths and areas of lots shall be not less than the required area in the Zoning Ordinance for the proposed land use and district in which the subdivision is located. If a private water supply or private sewage disposal will be used, the lot size must also meet the requirements of the County Health Department for the intended uses.
 - f. The depth-to-width ratio of the usable area of a lot shall be a maximum of 3 to 1. Building setbacks, easements, and buffer strips are not included as usable area when calculating the depth-to-width ratio.
 - g. Corner residential lots shall be wider than the average lot with the development in order to permit appropriate setbacks from

both streets. The usable lot width (total width less setbacks and easements) must be equal or larger than that of the average lot.

- h. For lots which contain water bodies, the number of acres or square feet of contiguous land area on the lot shall be at least equal to seventy-five (75%) percent of the minimum required lot size for the zone district in which the lot is located.

3. Streets and Access

- a. All parcels inside and adjacent to the subdivision must have adequate ingress and egress using existing roads and streets. If construction of new streets or a substantial improvement to an existing street is required for the subdivision, the subdivision shall meet the requirements of a Major Subdivision in VII-B.
- b. Frontage along a limited access highway does not constitute adequate ingress and egress access.
- c. Where existing county road right of way is less than desired for the classification of the roadway according to the Jackson County Transportation Plan, additional right of way shall be dedicated to the County wide enough to obtain $\frac{1}{2}$ the desired width from the centerline of the road.
- d. No existing parcel or parcel remnant may be landlocked due to the creation of proposed lots.
- e. Where access to an existing public street is determined to be impractical or where adequate street frontage does not exist, up to 4 lots may gain access to a public street or road by use of a private common access and utility easement. The following criteria shall apply to such easements.
 - i. Maintenance of the common access easement shall be the responsibility of the developer until such time that a written agreement with the lot owners has been reached for the maintenance responsibilities.
 - ii. The access easement shall be at least 50 feet in width, and shall not exceed 1,000 feet in length.
 - iii. The access easement must be located where topography allows for construction of a common driveway with a gradient of less than 10%.

4. Water Supply

- a. Potable water supply must be available to all proposed lots without extension or improvement to existing water mains or treatment facilities.
- b. Where private on-site wells are proposed for water supply, the approximate groundwater depth should be known and proper separation shall be provided from any on-site sewage disposal system.

5. Sewage Disposal

- a. Sewage disposal must be available to all proposed lots without extension or improvement to existing sewer mains or treatment facilities, unless private on-site sewage disposal is proposed.
- b. Where private on-site sewage disposal is proposed, each lot must provide adequate space for two (2) traditional non-repairable septic systems or use an approved repairable on-site system.
- c. Where private on-site sewage disposal is proposed, the developer must provide preliminary plans to the Jackson County Health Department and obtain written preliminary approval for the sewage disposal plan.
- d. Individual lot owners will still be responsible to obtain a construction permit for each lot prior to construction of the sewage disposal system.
- e. The preliminary sewage disposal plan shall show the proposed layout of lots with preliminary dimensions, soil types, land slopes, and locations where soil samples were taken. The plan should be accompanied by a report pertaining to use of the land for on-site septic systems from an approved soil scientist.

6. Drainage

- a. A Drainage Plan is required for all minor subdivisions. The drainage plan must be approved by the County Drainage Board and show the following:
 - i. Show existing drainage patterns, including any ditches, streams, wetlands, or flood hazard areas.

- ii. Show existing land cover with approximate boundaries of each type.
- iii. Show existing land slopes, either by use of contour lines or labeling approximate grades with directional arrows and approximate percent (%) grade.
- iv. Show approximate boundaries of different soil classifications based on the *Soil Survey of Jackson County, Indiana*.
- v. Proposed drainage pattern, including any proposed grading, culverts, or ponds that are anticipated within the subdivision.
- vi. Where proposed culverts or drainage pipes are necessary, provide calculations for peak runoff and pipe capacity.

B. Major Subdivisions

1. General Requirements

- a. The subdivision plan shall conform to the principles and standards which are generally exhibited in the Jackson County Comprehensive Plan, adopted September 19, 2006; and any amendments thereto.
- b. All construction improvements must be complete within the time limits established in Article V, Section D.
- c. Where a lot owners association is necessary for the maintenance of common area, storm water storage ponds, or to assure that the development stays within compliance with this ordinance and its own covenants, the association shall meet the following requirements:
 - i. Membership shall be automatic for all lot owners in the development.
 - ii. The association shall be incorporated.
 - iii. The developer must organize and finance the association until at least $\frac{2}{3}$ of the lots have

been sold and the construction of the streets, utilities, storm drainage system, and common areas are complete. At that time the developer will still be responsible for the membership of the lots which have not been sold and remain under the developer's ownership.

- d. All construction materials and procedures used to construct the subdivision must conform to the most recent Indiana Department of Transportation Standard Specifications and Drawings.
 - e. The design of the subdivision shall meet the requirements of this ordinance as well as follow the guidelines of the most recent editions of the Indiana Department of Transportation: Design Manual and the AASHTO: A Policy on Geometric Design of Highways and Streets. When the policies have conflicting or varied requirements, the most restrictive shall control.
 - f. Where existing natural features such as streams, wetlands, historic features, woodlots, mature trees, or any other natural features are identified, the subdivision should be designed to preserve such features in common area.
 - g. All flood hazard areas shall be identified and delineated on the subdivision plans. Other significant natural features such as wetland, steep terrain, ponds, or wooded areas should also be identified on the plans.
2. Lots -- The requirements of this section apply to lots which are intended to be used for private building sites. These requirements may not apply to common areas intended for open space, drainage detention, recreation, or other reasons.
- a. Where the subdivision is located within the jurisdictional fringe of the City of Seymour or within the corporate limits of any other City or Town, the lots shall conform to the minimum standards of the City or Town.
 - b. All lots shall provide suitable building sites. Features that affect suitability may include, but not be limited to steep grades, flood hazard areas, wetlands, or poor soils.

- c. All lots shall abut on a public street or approved access easement with minimum frontage as required by the zoning ordinance.
- d. Side lines of lots shall be at approximately right angles to tangent street sections and on radial lines along curved streets. Pointed or very irregular lots should be avoided. If the lot is accessed by an approved access easement, the right angle shall be measured from the easement.
- e. Double frontage lots are discouraged, except that, where desired along limited access highways, collectors, or arterials.
 - i. In those situations, lots should face an interior local street or subdivision street and back onto the major street. The rear lot line must also be shown “no access” on the plat.
 - ii. Where double frontage lots are created, the rear yard building setback shall be increased by 10 feet and a 10 foot wide landscape buffer easement shall run along the back of the lots.
- f. Widths and areas of lots shall be not less than the required area in the Zoning Ordinance for the proposed land use and district in which the subdivision is located. If a private water supply or private sewage disposal will be used, the lot size must also meet the requirements of the County Health Department for the intended uses.
- g. The depth-to-width ratio of the usable area of a lot shall be a maximum of 3 to 1. Building setbacks are not included as usable area when calculating the depth-to-width ratio.
- h. Wherever possible, unit shopping centers, based upon sound development standards, should be designed for the specific use and configured to most efficiently use the available space, rather than conforming to standards for typical individual lots.
- i. Corner residential lots shall be wide enough to permit appropriate front yard setbacks from both streets. The usable lot width (total width less setbacks) must be

equal or larger than the mean usable lot width in the development.

- j. For lots which contain water bodies, those lots must provide an equal or great amount of usable area as that of the mean usable area of all the lots in the subdivision. Usable area does not include building setbacks or area that could be covered by water during the maximum water level.

3. Blocks

- a. Blocks shall be of sufficient width to permit two tiers of lots of appropriate depth except where an interior street parallels a street of higher classification or a railroad right-of-way. The commission may also approve a single tier of lots if special land features prevent the use of two tiers of lots. Examples may include but not be limited to common spaces, recreation areas, water-front lots, or preservation of woodland and wetlands.
- b. Block length shall meet the requirements shown in Table VII-1. The length shall be measured between intersections of street centerlines.

	Urban Subdivision	Rural Subdivision	Commercial / Industrial
Min. Block Length	2 tiers of lots	400 Feet	200 Feet
Max. Block Length	600 Feet	1,200 Feet	1,200 Feet
Max. Cul-de-sac Length	600 Feet	1,000 Feet	600 Feet

Table VII-1: Block Lengths

- c. Cul-de-sac street length shall meet the requirements shown in Table VII-1. The length of a cul-de-sac street shall be measured from the center of the two intersecting streets to the center of the terminal radius of the cul-de-sac. The length of the cul-de-sac shall include any connecting street that does not have multiple points of access.

- c. Figure VII-1 illustrates a few examples of how block lengths and cul-de-sac lengths may be measured. Figure VII-1 does not address every situation, but provides a guide for common street layouts. Where a subdivision layout is unique due to environmental or topographic restrictions and evidence is provided to show that an alternate layout cannot be achieved, an alternate layout may be approved by the Commission.

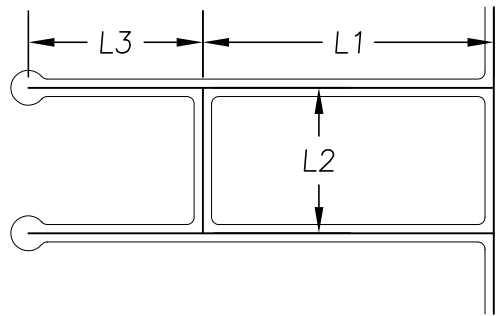

L1 = Block Length
 L2 = Block Length
 L3 = Cul-de-sac Length

Example #1

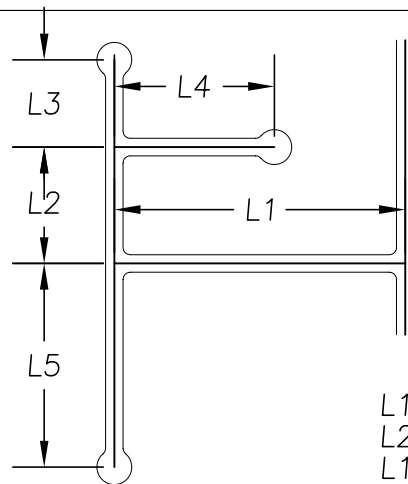

L1 = Block Length
 L2 = Block Length
 L1+L5 = Cul-de-sac Length
 L1+L2+L3 = Cul-de-sac Length
 L1+L2+L4 = Cul-de-sac Length

Example #2

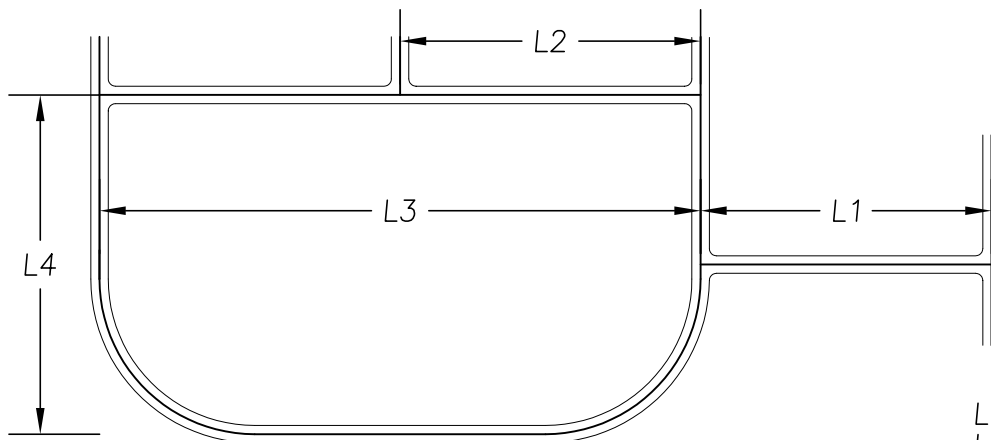

L1 = Block Length
 L2 = Block Length
 L3 = Block Length
 L4 = Block Length

Example #3

Figure VII-1: Block Length Samples

e. Where the internal street layout requires a street to loop as shown in example #3 on Figure VII-1, and the block length exceeds those shown in Table VII-1, the developer shall present alternate layouts with evidence showing the necessity of exceeding the standard block lengths. The Commission may approve a non standard block layout, where other options may not be feasible due to environmental concerns or restrictive topography.

4. Driveways

- a. Residential driveways are discouraged from having direct access onto arterial or collector streets and should be avoided on local streets when possible. Every effort should be made to arrange the streets and lots so that residential driveways will open directly onto subdivision streets.
- b. Residential driveways along subdivision streets shall be spaced at least 100 feet apart. When lots are less than 100 feet apart, one driveway will be permitted on each lot. Driveways should be combined, where possible, to allow 100 foot spacing between driveways.
- c. Driveway permits shall be obtained for all driveways with direct access to county roads or subdivision streets. Where the driveway is necessary to access directly onto a state highway, the permit must be obtained from INDOT.
- d. If a lot must have direct access to a collector or arterial street, the access points shall be kept to a minimum, with at least 150 feet between driveways.
- e. All driveway returns should have at least a 3 foot radius where the edge of the drive meets the curb line of the street.
- f. All driveways must provide a gradient to allow for a sidewalk or other pedestrian facility to cross the drive at grades in compliance with ADA. If a drive cannot be made at grade with the adjacent sidewalk, appropriate ADA ramps shall be installed in the sidewalk.
- g. Driveways shall provide minimum intersection sight distance as shown in Table VII-2. If areas existing in the subdivision where minimum intersection sight distance are not met, those areas shall be designated on

the plat as “no access” and no driveways shall be allowed in those areas.

5. Streets and Access

- a. All subdivisions shall have at least one access to an existing public or approved private street. Where a subdivision is to contain more than 50 lots, additional access streets shall be provided. Such access locations must be wide enough to provide room for required infrastructure and right of way to meet the requirements of this ordinance.
- b. Existing streets which provide access to the subdivision must be suitable for increased traffic and additional street intersections, or the developer shall provide a plan for improvement to the existing street and reach an agreement with the County for such needed improvements. The agreement should include responsibilities of the developer, responsibilities of the County, and a schedule for improvements.
- c. Where existing streets adjacent to the subdivision do not contain adequate right of way to comply with this ordinance, additional right of way shall be dedicated to provide $\frac{1}{2}$ of the prescribed width from the center of the street. The width shall be based on the requirements of this ordinance and the road classification found on the Jackson County Transportation Plan.
- d. Streets shall provide access to all lots with access wide enough to allow for driveways with reasonable grades and appropriate site distances.
- e. Where streets are not practical for access to common areas, access easements may be used for this purpose. The access easement must provide reasonable access to the common areas for maintenance equipment or emergency vehicles.
- f. All streets shall be given a street name that does not duplicate an existing street name in Jackson County. All street names shall be shown on the plat for the subdivision.
- g. Traffic Circulation: Effort shall be made to create traffic circulation within and adjacent to the subdivision. Consideration should be given to existing

and proposed use of adjoining land. The following list reflects some of the methods that may be utilized to create circulation.

- i. Where feasible, streets shall connect to adjacent future and existing subdivisions.
 - ii. The Commission may require temporary dead end streets to be created for future circulation. Where desired, they shall be limited in length to only extend along 1 lot beyond the corner lot at the street intersection. No more than 4 total lots may have direct access to a temporary dead end street.
 - iii. Where a dead end street is desired for future connection to adjoining land, the right of way may be platted without construction the street improvements. The improvements would then be installed upon development of the adjoining property.
 - iv. Permanent dead end streets are not permitted, except through the use of cul-de-sacs.
- h. Streets shall be designed with due consideration of the land topography, soil conditions, and natural features so as to produce usable lots, with safe and efficient access, meeting the minimum gradients found in Table VII-2.
 - i. Subdivision streets shall be designed to discourage through traffic or use of the subdivision streets as a short cut between adjacent local roads or collectors. Measures such as curved alignments stop controlled intersections, signage, and other traffic calming techniques are encouraged to make travel through the subdivision slower than traveling the local road system adjacent to the subdivision.
 - j. Private streets shall meet the same design and construction standards as streets which are proposed to be public streets.
 - k. Where proposed streets intersect with a state highway, the developer shall apply for and obtain a permit from INDOT for such intersection construction. Written approval from INDOT must be provided to the County.

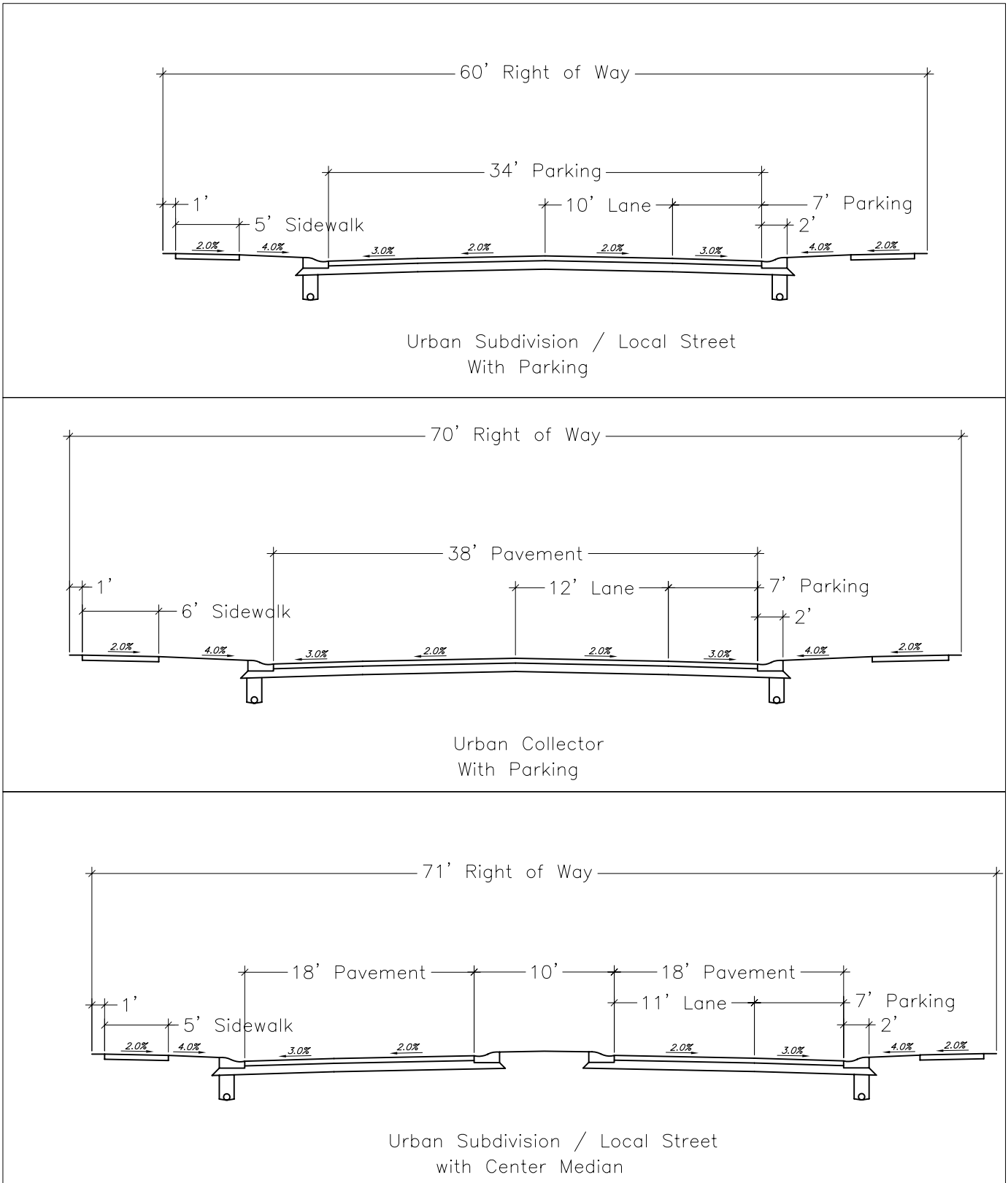

Figure VII-2: Urban Cross Sections

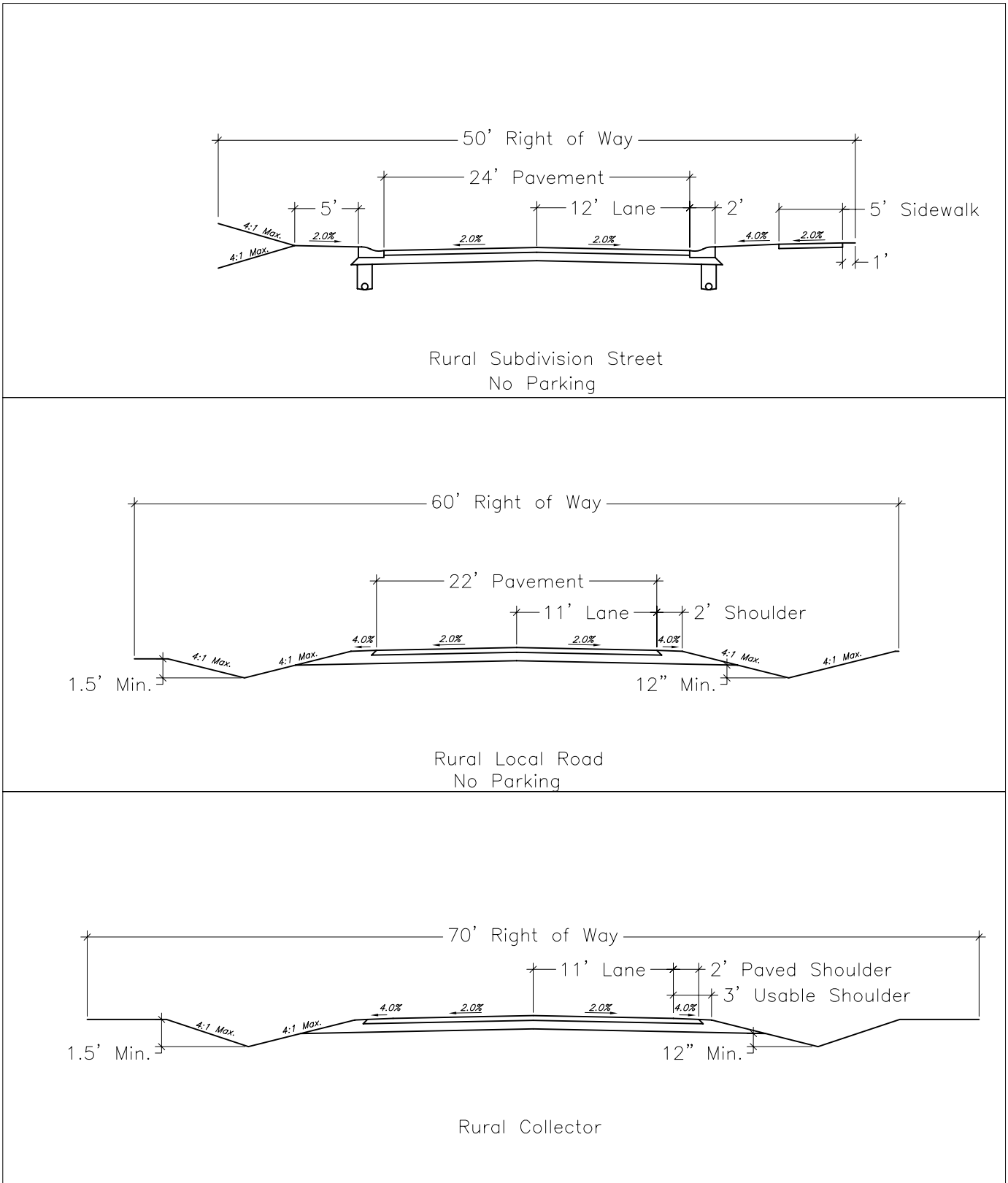

Figure VII-3: Rural Cross Sections

- l. All streets shall have pavement and right of way widths as shown in Figure VII-2: Urban Cross Sections and VII-3: Rural Cross Sections, based on the classification of the street.
- m. Streets shall conform to urban standards where the subdivision meets any of the following criteria:
 - i. It is within the jurisdictional fringe of the City of Seymour;
 - ii. It is adjacent to the corporate limits of any incorporated city or town in the county
 - iii. The median lot size is less than 0.5 acres.
- n. Streets may be designed using rural standards where the subdivision is not classified as urban due to the previous section.
- o. Cul-de-sacs streets shall be allowed with lengths as specified in subsection 3, Blocks. Cul-de-sacs terminus shall have a minimum radius of forty seven (47) feet to the edge of pavement, with at least thirty (30) feet of pavement width around the outside of the curve. The right of way around the terminal circle shall have at least fifty seven (57) foot radius. Figure VII-4 provides an illustration of the minimum standards for cul-de-sacs. A grading plan for the cul-de-sac shall be included in the improvement plans to assure the Commission that minimum grades will be met.

- p. Alleys, where used, shall have a minimum width of 20 feet.
- q. Streets shall intersect as nearly to right angles as possible, and shall in no case intersect at less than 70 degrees.
- r. At street intersections the edge of pavement corner radius shall be at least 15 feet for streets where the street width is 36 feet and at least 25 feet where streets are less than 36 feet in width.
- s. At street intersections the right of way lines shall corner with a 20 foot radius or the chord of such arc.
- t. Intersection of more than 2 streets at one location shall not be permitted.
- u. Where possible, streets should intersect to create 4-legged intersections where both streets continue through. Offsetting 3-leg intersections should be avoided, but if required, they must be offset by at least 150 feet.
- v. At intersections, the minor street must be controlled either by traffic signs or signals. The intersections shall provide minimum site distance as shown in Table VII-2. Where the approaching major street has a downhill grade greater than 3%, the site distance must be increased accordingly.
- w. The commission may approve the use of a parkway or boulevard street design with a median in the center of the street. Where used, the following criteria shall be met:
 - i. Minimum widths of street, sidewalk, and median are shown on Figure VII-2: Urban Cross Sections.
 - ii. All parkway or boulevard streets shall be curb with storm sewers.

- iii. The median shall have breaks for traffic to cross at all street intersections or commercial driveways. The break in the median shall be at least the width of the intersecting drive or street, with a minimum width of thirty (30) feet.
- iv. Medians shall be landscaped in some manner, even in only sod or mulch to prevent erosion. Landscaping shall be shown on the improvement plans and shall not create any obstruction to required sight distances for intersections or driveways.
- x. All streets shall be constructed at or above the base flood elevation (100-year) where a flood hazard has been identified.
- y. Streets shall be constructed with horizontal and vertical alignments to provide adequate intersections sight distances and stopping sight distances for the appropriate design speeds. Table VII-2 shows some minimum requirements. Sag vertical curves, crest vertical curves, and horizontal curves all must be checked for sight distance.
- z. Curved streets shall have minimum radii as shown in Table VII-2 and use the appropriate amount of superelevation for the design speed and radius. Where superelevation is not used or is less than the allowed maximum, the radius shall be increased accordingly.
- aa. Superelevation may be used to reduce the radius of a curved street, except for urban subdivision and local street. The maximum allowable superelevation rates are shown in Table VII-2.

Type of Street	Urban Subdivision / Local	Urban Collector	Rural Subdivision / Local	Rural Collector
Design Speed (MPH)	30	40	40	55
Stopping Sight Distance	200	305	305	495
Intersection Sight Distance	335	445	445	610
Min. Radius (feet)	333	593	533	1060
Min. Grade	0.30%	0.30%	0.30%	0.30%
Max. Grade	8%	7%	10%	7%
Max. Superelevation Rate	Not Allowed	2%	4%	6%

Table VII-2 Street Geometry Standards

bb. All streets shall be paved with hot mix asphalt. The pavement shall be designed based on the soil conditions of the site and the expected traffic. Minimum pavement sections are shown in Table VII-3.

Type of Street	Urban Subdivision / Local	Urban Collector	Rural Subdivision / Local	Rural Collector
HMA Surface	1"	1 ½"	1 ½"	1 ½"
HMA Base	2"	2 ½"	2 ½"	3 ½"
Compacted Aggregate Base, #53	8"	10"	6"	8"

Table VII-3 Minimum Pavement Thickness

6. Street Signage shall be provided by the developer:

a. All streets shall include street signage according to the current edition of the Manual on Uniform Traffic Control Devices for Streets and Highways (MUTCD) as published by the U.S. Department of Transportation, Federal

Highway Administration. Where the proposed street will have less than 400 AADT and shall be classified as a local street, the signage may follow the requirements for “Low Volume Roads” in the manual.

b. Street name signs shall be placed at all street intersections. Urban local / subdivision streets may use 4” minimum letter height, but street name signs along collector streets or rural streets must follow the MUTCD standards with a 6” minimum height.

7. Street Lighting may be desirable, but is not require. Where street lighting will be installed, the following requirements shall be met.
 - a. Proposed light locations and type of lights must be shown on the plans.
 - b. The developer will be responsible for installation.
 - c. An agreement between the electric utility and either the developer or the lot owners association must be executed to ensure who is responsible for monthly cost of electricity for street lights, unless a street lighting agreement can be reached with an incorporated city or town.
 - d. When street lights are installed, lights must be placed at all street intersections, pedestrian crossings, bridges, and any other street feature that may need improved visibility.
8. Bridges and Culverts: Where a bridge or culvert is necessary in a subdivision to carry a roadway over a stream or ditch, the developer shall provided such stream crossing to meet the following minimum requirements.
 - a. Where the stream is found to be a jurisdictional stream or navigable waters by the regulatory agencies, the developer is responsible for any and all required permits and must meet the conditions of those permits.
 - b. The minimum culvert size crossing a public road shall be 15” in diameter. Culverts for driveways may be 12” diameter.
 - c. Where a bridge or culvert is 20’ or more in span (measured along the centerline of the road), the structure shall be classified as bridge and must be added to the County’s bridge

- inventory upon completion. All bridges shall be subject to inspection by the County's bridge inspection engineer.
- d. Structural design of all bridges shall follow the guidelines of the AASHTO *Load and Resistance Factor Design (LRFD) Bridge Design Specifications*.
 - e. Where piers are necessary for multiple span structures, the piers should not be located in the flow of the main channel.
 - f. The superstructure (beams and/or deck) shall be above the 100-year flood frequency elevation.
 - g. The roadway at the bridge approaches shall be at least 1 foot above the 100-year flood elevation.
 - h. All structures shall provided a minimum clear roadway width over the structure of either the width of the travel lanes plus shoulders or the width from back of curb to back of curb. No structure shall be less than 28' in width.
 - i. Culverts (less than 20' span) must not create more than 1' of surcharge (flow depth at the upstream right of way – tailwater depth at the downstream right of way) during a 100-year frequency design storm.
 - j. Culverts shall provide 1' of freeboard below the edge of pavement for a 10-year design storm, and should not allow roadway overflow for a 25-year frequency design storm on local roads and a 50-year frequency design storm for collectors or arterials.
 - k. Bridges shall be protected with bridge rail and approach guardrail appropriate for the design speed of the street.
 - l. Culvert ends should be placed beyond the roadway clear zone (per INDOT Design Manual for local agency local roads), be protected by guardrail from an errant vehicle, or use an appropriate end treatment to prevent the culvert end from creating a hazard to an errant vehicle.
9. Landscaping may be necessary in some subdivisions. A landscape buffer is required when a subdivision is designed to have rear lot lines adjacent to street right of way. The landscape screening shall be planted in an easement with a minimum width of 10 feet. The landscape easement width is in addition to utility or drainage easements which may also be located along the rear lot lines.

10. Easements shall be provided for utilities, drainage, and access or installation and maintenance of utilities, storm drainage, and common areas.
 - a. Easement locations and widths must be coordinated with utility companies to assure that the needs of each utility will be met.
 - b. Easements must maintain a minimum width of 10 feet when located adjacent and parallel to street right of way. When easements are not along streets, a minimum width of 16 feet shall be provided. When located along lot lines the easement may be $\frac{1}{2}$ on each side of the lot line.
 - c. When an easement is located along the outer boundary of the subdivision, the minimum width must be provided either by the whole width being within the subdivision or by obtaining part of the easement from the adjoining parcel. The width may not be less than the minimum required based on possible future development of the adjoining property. If a primary plat for the adjoining parcel is to include $\frac{1}{2}$ of the easement, the developer must plat the whole easement in order to develop the earlier phase.
 - d. Easements should provide continuity from block to block.
11. Where a subdivision includes storm water storage facilities, at least 16' must be provided beyond the water's edge at the highest water level either in the form of common area, or easement for maintenance and access around the entire perimeter of the storage facility. The minimum width is shown in Figure VII-5.

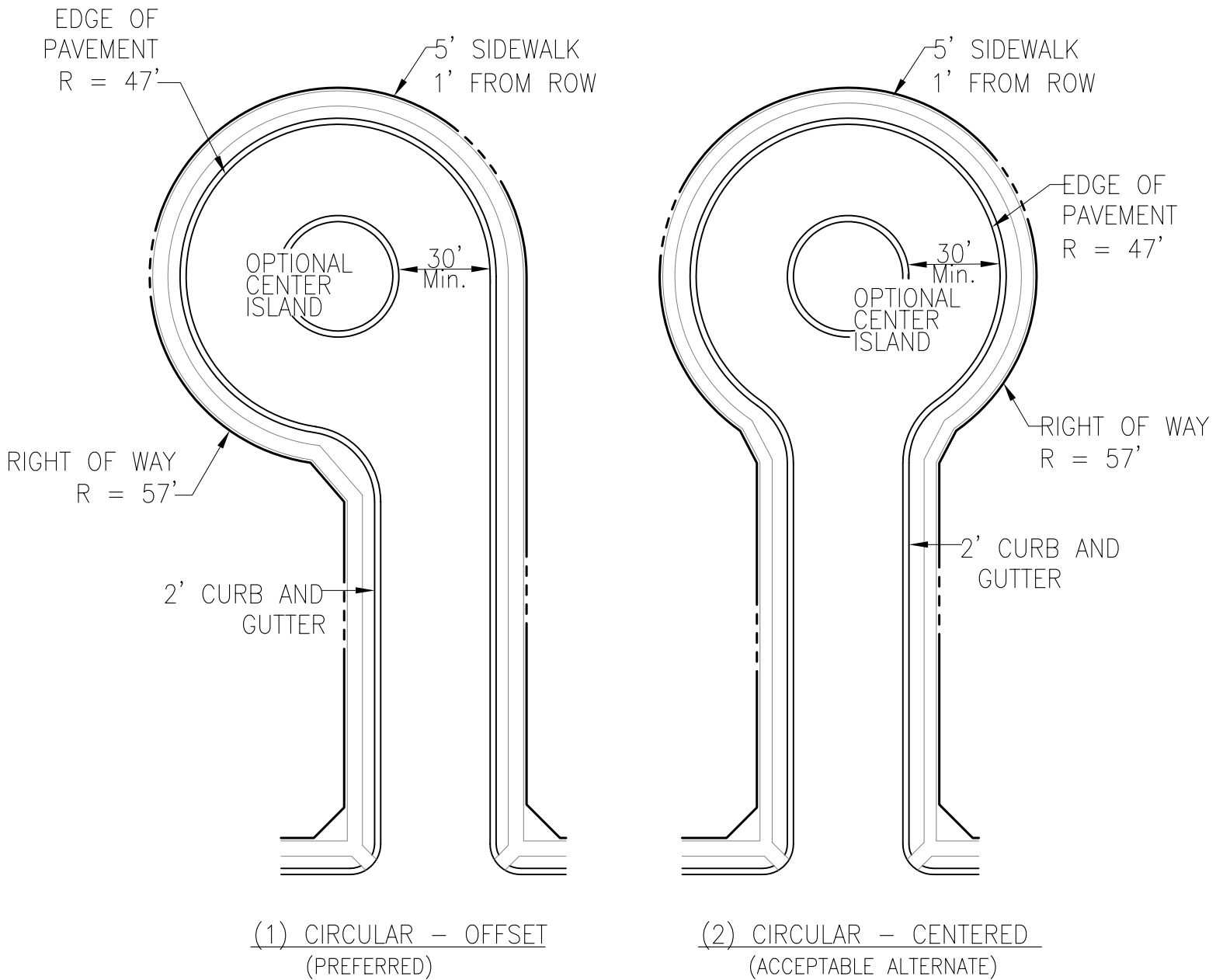

Figure VII-4: Cul-de-sac Plan

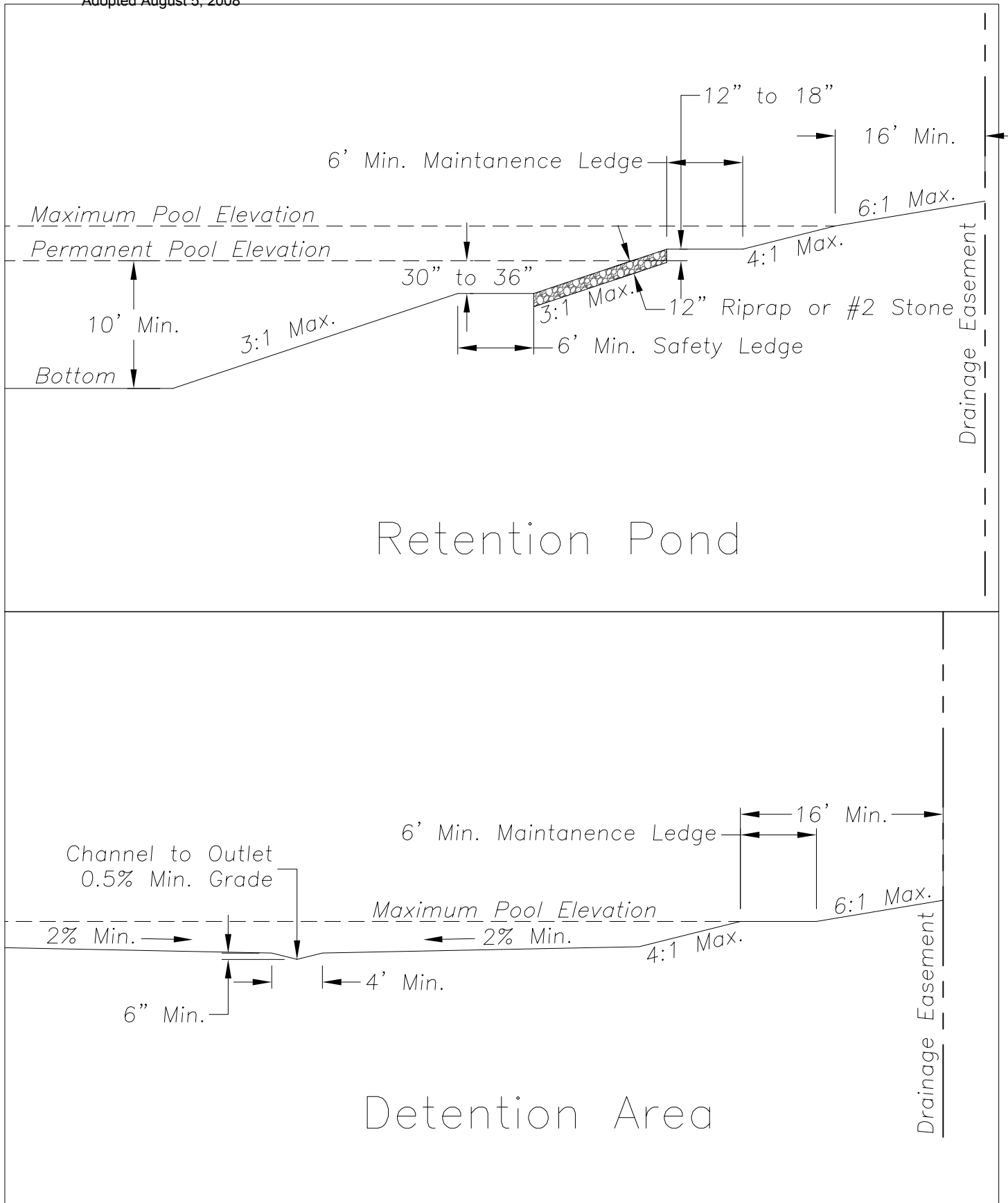

Figure VII-5: Pond Typical Sections

12. Drainage & Storm Water

- a. Natural drainage patterns and natural stream channels shall be maintained wherever possible.
- b. Stream channels subject to the jurisdiction of the Indiana Department of Natural Resources or U.S. Army Corps of Engineers shall not be altered without written approval from all applicable agencies.
- c. Existing drainage from an adjacent property that is upstream may not be blocked or restricted in any way.
- d. The flow rate discharged from the development must not exceed the discharge under existing land use conditions for both the 10 year frequency design storm and the 100 year frequency design storm. Storm runoff may not be discharged directly onto an adjoining property only at the same location as the existing discharge to prevent damage to downstream property.
- e. The subdivider shall design and construct a drainage system to handle surface water from the entire subdivision and the drainage area of which it is a part.
- f. The designer shall drainage computations to exhibit compliance with the standards contained in this ordinance and evaluate the ability of the existing and proposed drainage system to handle the runoff. This report must be certified by a registered professional engineer or land surveyor in the State of Indiana. The report shall address both existing and proposed conditions and shall address the following:
 - i. Hydrologic information and calculations, including drainage areas, soil types, topography, methodology, and peak discharges for each design storm.
 - ii. Hydraulic calculations for ditches, gutters, inlets, pipes, culverts, bridges, or other conveyance system to show capacity of all drainage infrastructures is adequate.
 - iii. Where retention or detention areas are part of the drainage system, calculations must be provided for the inflow and outflow of the proposed holding area, the peak discharge, and peak storage elevation. The peak

discharge shall be compared to the existing (pre-developed) conditions.

- g. Underdrains shall be provided unless a Geotechnical Report proves that they are not necessary. Underdrains shall meet the following criteria:
 - i. The trench shall be lined with geotextile fabric when silt or loam soils will be encountered.
 - ii. The perforated drain pipe shall be at least 4" in diameter or of an equivalent area.
- h. The minimum trench width shall be 12" to allow 4" on each side of the underdrain pipe. If large pipe is used, the trench should be widened accordingly.
- i. The trench shall be backfilled with Size No. 8 or 9 course aggregate.
- j. The drain shall be at least 12" below the subgrade of the road.
- k. The minimum grade for underdrain pipe is 0.3%.
- l. The storm drainage system shall be separate and independent of any sanitary sewer system.
- m. Design rainfall depths and rainfall intensities used to calculate runoff shall be taken from NOAA's National Weather Service for the observation site nearest to the subdivision (National Weather Service, Office of Hydrologic Development, Hydrologic Data Systems Branch, Hydrometeorological Design Studies Center).
- n. Storm sewers on local and subdivision streets shall be designed so that a 10-year frequency design storm will not create gutter spread more than 4 feet into the travel lane and have hydraulic capacity to flow without pressure in the pipe network.
- o. Curb inlets may not be spaced more than 400 feet apart or 400 feet from the crest of a high point in the road profile.

NOAA's National Weather Service data can be obtained at <http://hdsc.nws.noaa.gov/>

13. Water Supply

- a. The developer shall install a public water system to serve the project, where the subdivision is classified as Urban Subdivision or where a public water system is available within ¼ mile (1,320') of any point on the boundary of the proposed

subdivision. Written authorization to connect to the public water system must be provided from the public water utility.

- b. The water system must comply with the Great Lakes Upper Mississippi River Board of State Public Health and Environmental Managers *Recommended Standards for Water Works*. If the water utility or service provider requires a higher standard, the subdivider shall comply with all such requirements. The developer is responsible for obtaining all necessary approval from the Indiana Department of Environmental Management.
- c. Fire hydrants shall be installed with a maximum spacing of 1,000 feet between hydrants and must not be more than 500 feet from any residence with the subdivision.
- d. The location of all water supply system components, including but not limited to main piping, valves, and hydrants shall be shown on the improvement plans. All such improvements shall be installed at the cost of the developer.
- e. Where a public water system is not available for connection of the proposed subdivision, the developer shall provide individual water supply on each lot of the subdivision through use of on-site wells. The developer is responsible for making sure that the water is safe to drink under the standards of the EPA and the authority of the Safe Drinking Water Act. Each lot's water supply shall be tested, at a minimum, for nitrates and for the presence of coliform bacteria, as well as any other specific contaminants that may requested by the County Health Department based on knowledge of the project area. The developer is responsible for the testing and the associated cost for the testing. Proof of testing and test results shall be provided to the Jackson County Health Department prior to occupation of any lot.
- f. The developer shall obtain written acknowledgement from the Jackson County Health Department that appropriate procedures and guidelines have been met by the developer for the proposed water supply.

14. Sewage Disposal

- a. The developer shall install a sanitary sewer system to serve the entire subdivision, where the subdivision is classified as Urban Subdivision or where an existing state approved sewer system is available within ¼ mile (1,320') of any point on the

boundary of the proposed subdivision. For purposes of this section, an available system is one with sufficient capacity that can be utilized via existing rights-of-way or easements employing gravity flow or lift stations with force mains.

- b. The sewage disposal system must comply with the Great Lakes Upper Mississippi River Board of State Public Health and Environmental Managers *Recommended Standards for Wastewater Facilities*. If the water utility or service provider requires a higher standard, the subdivider shall comply with all such requirements. The developer is responsible for obtaining all necessary approvals from the Indiana Department of Environmental Management for construction of the sanitary sewers.
- c. The horizontal and vertical location of all sewer system improvements shall be shown on the improvement plans and installed at the cost of the developer.
- d. Written authorization to connect to the existing sewer system must be provided from the accepting sewage facility.
- e. Where a sanitary sewer system is not available, as specified in subsection A, to serve the proposed subdivision, the Commission may approve the use of private individual on-site systems (septic system) or the use of an on-site cluster septic system.
- f. Where individual on-site septic systems are proposed, the following requirements shall apply:
 - i. Each lot shall be of adequate size to accommodate two (2) traditional (non-repairable) septic absorption fields, unless the developer provides the Commission with a written commitment to utilized repairable septic systems.
 - ii. Evidence must be provided to the Jackson County Health Department to assure that each lot has acceptable land slopes, soil conditions, spacing from water supply wells, and lot size for the systems being proposed. A map of soil types shall be included with the improvement plans.
 - iii. The system shall be designed and installed in accordance with current regulations of the Indiana State Department of Health and those of the Jackson County Health Department

- iv. Each system shall be entirely located on the lot being served.

- g. A cluster septic system designed to serve multiple lots may be approved by the commission, where desired lot sizes, soil conditions, or other special conditions exist, and only after ensuring that a binding arrangement is in place to ensure continued and effective operation and maintenance of the system. The developer must provide the Commission with the following:
 - i. A copy of the construction plans for the system with certification from a Registered Professional Engineer.
 - ii. A long term financial plan which includes a plan for collection of fees sufficient to cover the operation and maintenance of the system.
 - iii. Qualifications of the firm or individual who will be responsible for the operation and maintenance of the system to ensure that the system remains compliant with state water quality standards.
 - iv. Assurance that the system will have the ability to continuously operate during electrical power outages.
 - v. Assurance that all required inspections and reports required by IDEM, ISDH and Jackson County Health Department will be completed.
 - vi. Provisions authorizing the County to collect fees and levy fines against the property owners singly and collectively in the event that the system is not operated and maintained as proposed.

15. Pedestrian Facilities

- a. Sidewalks shall be required on at least one side of the street on all urban subdivisions, any subdivisions with lot sizes less than 1/3 acre, and in subdivisions adjacent property where sidewalks or other pedestrian facilities exist.
- b. Where a proposed subdivision, which requires sidewalks, is intersected by or adjacent to an existing street without sidewalks, the developer shall add sidewalks to such existing streets.

- c. Sidewalks shall be located inside the street right of way as shown on the Typical Street Cross Sections of this ordinance. The Commission may approve an alternate location of the pedestrian facility where unusual terrain or land features prevent placement according to the standards.
- d. Sidewalks shall be constructed at least 4 inches thick and 5 feet wide from 3,000 psi strength cement concrete. Where pedestrian trails are approved in areas other than along streets, the Commission may approve the use of hot mix asphalt (HMA). Where HMA is used, it shall be constructed with 3" HMA over 4" Compacted Aggregate No. 53.
- e. Concrete sidewalks shall have contraction joints no more than 6 feet apart, with a depth $\frac{1}{4}$ the thickness of the sidewalk.
- f. Sidewalks shall meet Americans with Disabilities Act (ADA) requirements for clearances and slopes.
- g. Sidewalk ramps are required where sidewalks intersect or cross streets. At these locations, the ramp shall be flush with the gutter at the edge of the street and provide for positive drainage away from the ramp. Drainage structures shall not be located within the limits of a sidewalk ramp.

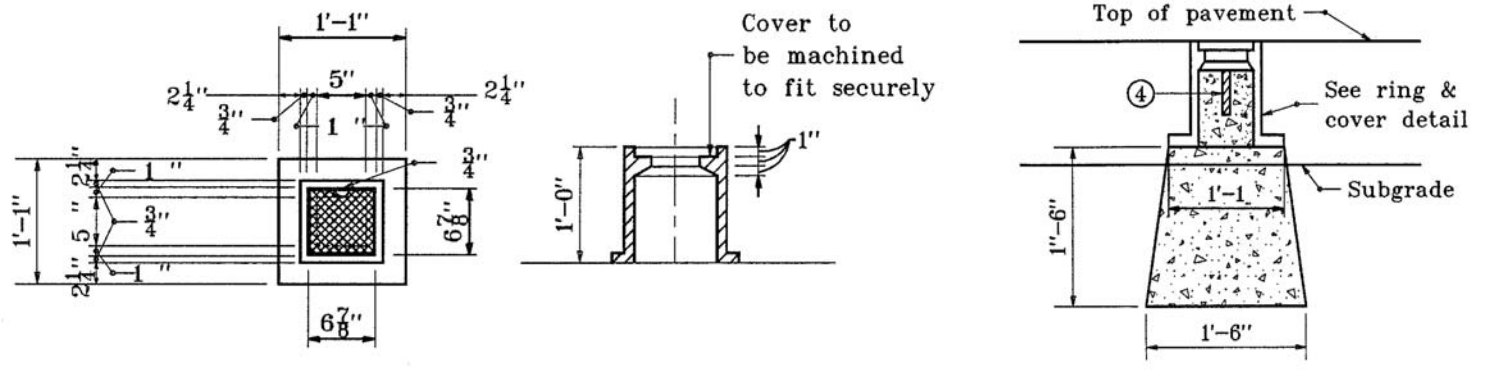
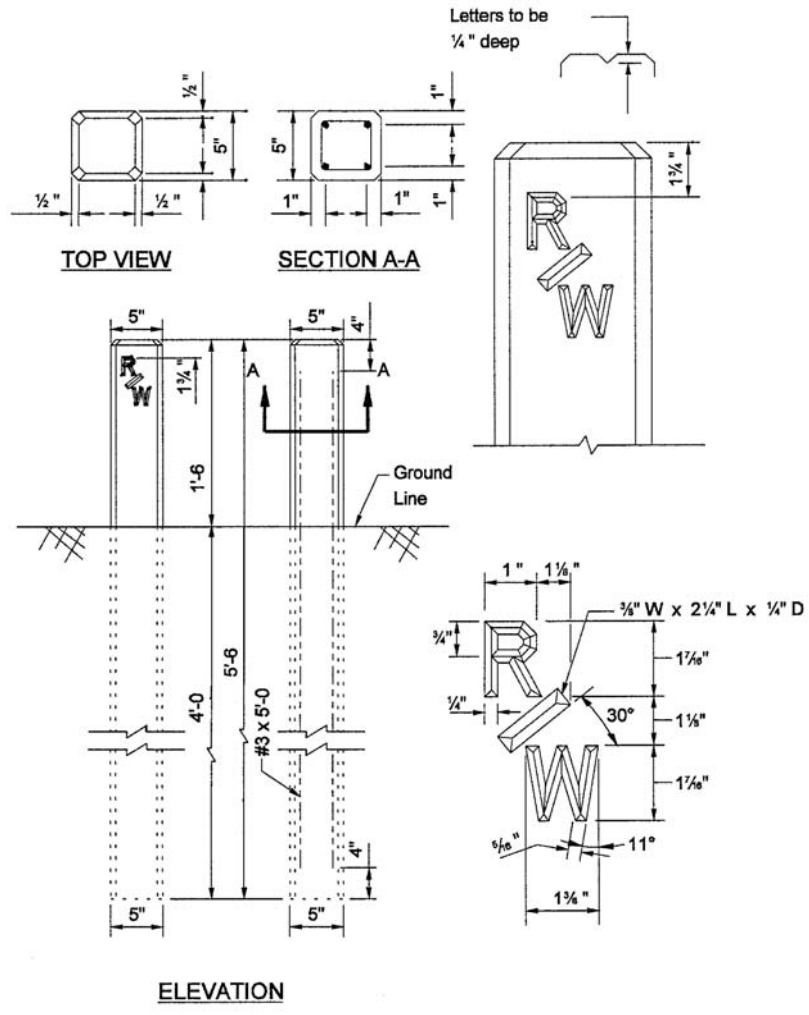

Sample INDOT Standard Survey Monuments
 Exhibit VII-6

16. Monuments and Markers

- a. The improvement plans shall show both the location and type of monuments and markers to be installed. All monuments and markers must be installed by the developer prior to the County accepting the construction of the subdivision improvements or the release from financial guarantees.
- b. Monuments and markers shall be placed so that the marked point shall coincide with the intersection of lines to be marked, and shall be set so that the top of the monument or marker is level with the surface of the surrounding ground after final grading. Monuments and markers shall be installed as required by the following sections.
 - i. Monuments shall be set at the following locations:
 1. Intersections of all lines forming angles in the boundary of the subdivision;
 2. Beginning and end of all curves that form part of the boundary of the subdivision;
 3. Intersections of all existing and proposed street right of way lines with the boundary of the subdivision or with another street right of way.
 - ii. Markers shall be set at the following locations:
 1. All intersections of lot lines with other lot lines, boundary lines, or street right of way;
 2. Intersections of all lines forming angles in lot lines or street right of way lines inside the subdivision;
 3. Beginning and end of all curves that form part of a lot line or street right of way line within the subdivision.
- c. Monuments shall be concrete with a minimum size of four (4) inches by four (4) inches by thirty six (36) inches deep, and shall be marked on top with an iron or copper dowel imbedded in the concrete and flush with the top surface. Along street right of way, standard INDOT right of way markers may be used as an alternative monument. A copy of the INDOT R/W marking is shown in Exhibit VII-6.

- d. Where a monument must be located in pavement, a one (1) inch diameter by five (5) inch long steel rod shall be placed in concrete and protected by a ring and cover as shown in the INDOT standard drawings for survey line monuments. A copy of the detail is included as Exhibit VII-6.
- e. Markers shall be steel or iron bars at least thirty (30) inches long by five eighths (5/8) inches in diameter.
- f. When a section corner is located within or adjacent to the subdivision, the section corner shall be marked as directed by the County Surveyor.

17. Public Sites, Common Areas, and Open Space

- a. Where locations for parks, schools, playgrounds, or other public uses are shown in the Jackson County Comprehensive Plan and located in whole or in part within the subdivision area, the Commission may require the reservation of such area for a period of five (5) years from the date of secondary plat approval. Where deemed essential by the Commission upon consideration of a development based on the particular type or size, especially a large development that was not anticipated by the Comprehensive Plan may also require the same reservation of land for a five (5) year period.
- b. Any portion of the subdivision designated as common facilities or open space shall remain undivided. Ownership of the land may be one of the following methods:
 - i. The land may be owned through undivided interest of each lot owner.
 - ii. A lot owners association may own the land under the following criteria:
 - 1. The association shall be responsible for insurance and taxes on the land with the authority to place liens on the property of any of its members who fail to pay association dues in a timely manner.
 - 2. The association shall have adequate staff or contracts w/ outside vendors to manage the common facilities, maintain the land in good condition, and handle the financial and business affairs of the association.

3. The association shall provide an annual report with a list of association officers to the Plan Commission.
- iii. A recognized land trust or conservancy group which must be an incorporated non-profit organization having as a primary purpose the conservation of open space, natural areas, and/or agricultural land.
- iv. Dedicated to the County, only if the County Board of Commissioners accept such dedication

18. Survey, Plans, and Plat Standards

- a. All surveys shall be conducted and plats prepared by a Registered Land Surveyor and in accordance with Rule 12 of the Indiana Administrative Code and any amendments thereto. Where a conflict may arise between Rule 12 and this ordinance, the stricter standard shall be applied.
- b. Improvement plans may be prepared by either a Registered Land Surveyor or a Registered Professional Engineer in the State of Indiana.
- c. All plans and plats shall be neat, legible, reproducible, and reducible. Plans and plats shall conform to the following criteria:
 - i. Drawing sheets shall be no larger than thirty six (36) inches wide by twenty four (24) inches tall.
 - ii. The scale on plans and plats should be as large as possible for clarity and reproducibility. However, horizontal scale shall be at least one inch to sixty feet (1" = 60'), with one inch to fifty feet (1" = 50') or larger being preferred. Vertical scale for roadway or sewer profiles shall be either one inch to ten feet (1" = 10') or one inch to five feet (1" = 5'). Roadway cross sections also shall be either one inch to ten feet (1" = 10') or one inch to five feet (1" = 5'), with horizontal and vertical scales being the same.
 - iii. All plan and plat sheets containing symbols or abbreviations must also contain a legend for such symbols and abbreviations.

For more information, see 865 IAC 1-12-1 Rule 12: Land Surveying; Competent Practice
--

19. All infrastructure proposed to be installed shall be shown on the improvement plans with financial guarantee provided to the

appropriate agencies of whom will eventually take ownership of such facilities. At a minimum the following infrastructure items shall be shown in the plans and included in the cost estimate provided to the County. The required amount of financial guarantees will be based on this estimate.

- a. Site grading (including detention areas, if applicable)
- b. Erosion Control (includes silt fence, ditch check dams, and temporary seeding)
- c. Traffic Control and Street Signage (includes construction signs, street name signs, and subdivision name sign)
- d. Streets, sidewalks, guardrail, and storm drainage
- e. Landscaping (may include berms, plantings, and fence)
- f. Sanitary sewer and water supply

VIII Improvements and Financial Guarantees

A. Completion of Improvements

All improvements required by the Commission, including, but not limited to streets, sidewalks, water and/or sewer utilities and erosion control shall be shown on the improvement plans and must be completed within two years from the date of approval, with the following exceptions:

1. If sidewalks are to be installed as lots are developed, the County Commissioners may approve time extensions for sidewalk completion with the submission of an appropriate financial guarantee. Each extension shall be for a maximum of two years, and no more than 3 such extensions may be granted. In deciding whether to grant the extension, the Commissioners shall consider the degree of completion of construction in the subdivision, the effect of the extension on property owners in the subdivision, and weather or other conditions affecting construction.
2. The County Highway Engineer may make a recommendation to the County Commissioners to approve a time extension for installing the final paving course (surface coat) with the submission of an appropriate financial guarantee. The time extension shall be for a maximum of one year, and only one such extension may be granted. In making the recommendation, the engineer shall consider the degree of the completion of the subdivision, the effect of the extension on property owners in the subdivision, and weather or other conditions affecting the construction. The commissioners' decision shall be final.
3. The Commissioners may approve other extensions of time with the submission of an appropriate financial guarantee if unusual conditions exist that impede timely completion. In deciding whether to grant the extension, the Commissioners shall consider the degree of the completion of the subdivision, the effect of the extension on property owners in the subdivision, and weather or other conditions affecting the construction.

B. Secondary Approval and Performance Guarantees

A subdivision plat may be recorded only after a subdivision improvement agreement is accepted by the county and Secondary Approval has been given as specified in this ordinance. Secondary approval shall not be given until one of the following has been accomplished:

1. The County Commissioners has accepted for perpetual maintenance required public improvements and all improvements have been inspected and satisfactorily completed in accordance with the approved plans.

2. The applicant has posted financial guarantees in an amount equal to 100% of the cost of the improvements. The form and length of these performance guarantees must be acceptable to the county attorney. If time extensions are granted, the cost estimate must be reviewed and the amount of the guarantee increased if necessary.

C. Maintenance Guarantees

As a condition of the acceptance of completed improvements and/or release of financial guarantees posted under the terms of this section, the subdivider shall post with the County Commissioners financial guarantees ensuring maintenance of the improvements in good repair. These guarantees shall be in an amount equal to a minimum of 25% of the estimated cost of all improvements and shall be in effect for a period of three years.

D. Form of Financial Guarantees

A surety bond shall be considered the acceptable form of a financial guarantee. Letters of credit are not acceptable.

E. Release of Financial Guarantees

1. After completion of all public improvements and prior to the release of the performance guarantee on the improvements, the subdivider shall provide drawings showing "as-built" plans for any substantial change, such as the actual location of road improvements, sanitary and storm sewer improvements, water mains, fire hydrants, improvements, valves and stubs, monuments and markers, drainage facilities and other installed permanent improvements. A registered engineer or land surveyor shall certify this map. One copy of these plans shall be submitted to the County Highway Department and one copy shall be submitted to the Office of the Building Commissioner.
2. The County Commissioners may grant a partial release from a financial guarantee for portions of the improvements which are complete and accepted by them, provided that the maintenance guarantee as specified in this ordinance is posted for such portion of the improvements.
3. The financial guarantee shall not be released until:
 - a. The subdivider has provided acceptable evidence that an entity has been established to maintain any common facilities, including but not limited to open space, recreational facilities, pedestrian systems, and drainage facilities, and;
 - b. The sidewalks are complete.

F. Inspection

1. Preconstruction - Before beginning any work within the subdivision, the developer shall meet on the site with the County Highway Engineer or his/her representative.
2. Construction - The appropriate County officials shall inspect and require that the installation of all improvements take place in accordance with plans approved by the Commission. The County shall have authority over the schedule of construction, materials used, methods of construction, and workmanship to ensure compliance with the approved plans.

IX Enforcement and Penalties

A. Plat Validity

No plat of any subdivision of land, as defined by this ordinance, shall be entitled to record in the County recorder's office or have validity until approval is granted under the terms of this ordinance. Any such plat not properly approved shall not be entitled to an improvement location permit or a building permit.

B. Complaint

Whenever a violation of this Ordinance occurs or is alleged to have occurred, any person may file a written complaint. Such complaint stating fully the causes and basis thereof shall be filed with the staff. The staff shall properly record such complaint and immediately investigate.

C. Civil Subdivision Control Violations

Any person who is in violation of the Subdivision Control Ordinance of Jackson County shall be deemed to have committed a civil subdivision control violation and may be issued a citation by the designated enforcement entity. The Subdivision Control Ordinance of Jackson County is included under a list of ordinances scheduled for the jurisdiction of the Ordinance Violations Bureau.

Each day a violation remains uncorrected is a distinct and separate civil subdivision control violation subject to an additional citation and fine in the amount prescribed below, provided a warning ticket has first been issued.

1. The monetary fine for each civil subdivision control violation shall be \$100.00, except that for a repeated subdivision control violation, the following fines shall apply: Second Citation -- \$ 150.00, each Citation in excess of two -- \$200.00.
2. All fines prescribed by this section for civil subdivision control violations shall be paid within 72 hours to the Violations Clerk of the Ordinance Violations Bureau, who shall render to the person making the payment a receipt stating the amount and purpose for which the fine has been paid, and duplicate of which shall be made a part of the records of the Plan Commission. All fines thus received shall be deposited with the Jackson County Treasurer.

D. Citation for Civil Subdivision Control Violations

1. The Building Commissioner and/or his duly authorized designees, as designated at a County Commissioner's meeting, may issue a civil subdivision control violation to a person who commits a civil subdivision control violation to the legal owner, the contract vendee, or any person or entity with a possessory interest in the real estate upon which the violation occurs. The citation may be served by personal service, by certified mail, or by placement in a conspicuous place on the property where the violation occurs and shall serve as notice to a person that he or she has committed a civil Subdivision Control Ordinance violation.
2. No citation shall be issued for the first offense unless the person who commits a civil subdivision control violation, or the legal owner, the contract vendee, or any person or entity with a possessory interest in the real estate upon which the violation occurs has been issued a warning ticket before the issuance of the citation to allow said person to correct the violation to come into compliance with the prescribed Subdivision Control Ordinance or regulations.
3. A person who receives a warning ticket or a citation may either choose to abate the violation or file a petition for a subdivision plat, a Subdivision Control Ordinance modification, or other means provided by this ordinance to correct the violation. A person who elects to file such a petition shall indicate this intent in writing to the issuing agency. A person shall have 10 working days after issuance of the warning ticket to file the petition, and additional monetary fines shall be stayed upon the filing of such petition, as long as the violation does not continue at the real estate. A person who files the petition within said time period shall pursue the petition in an expeditious fashion. If the petition is denied, withdrawn, or dismissed for want of prosecution, and the civil subdivision control violation continues at the real estate, then a lawsuit will be commenced by the designated enforcement entity in a court of competent jurisdiction in Jackson County, Indiana.
4. If a person believes that the warning ticket or citation received results from an incorrect interpretation of the Jackson County Code by a county official, the aggrieved person may file an administrative appeal of the decision for a hearing by the Board of Zoning Appeals. Said appeal shall be on the form prescribed and shall include payment of the appropriate filing fee. A

person who elects to file such an appeal shall indicate this intent in writing to the issuing agency. A person shall have 10 working days after issuance of the warning ticket to file the appeal, and additional monetary fines as prescribed in this ordinance shall be stayed upon the filing of such appeal, as long as the violation does not continue at the real estate. A person who files the appeal within said time period shall pursue the appeal in an expeditious fashion. If the BZA upholds the interpretation of the Subdivision Control Ordinance that led to issuance of the warning ticket or citation, and the civil subdivision control violation continues at the real estate, then a lawsuit will be commenced by the designated enforcement entity in a court of competent jurisdiction in Jackson County, Indiana.

5. If the violation is determined by the Building Commissioner or his/her designee to be a threat to public health or safety, the Director or his/her designee may order the land use or activity to cease and desist immediately, regardless of whether a warning ticket or citation has been issued.
6. The warning ticket shall be in the form prescribed by the Plan Commission.
7. The Citation shall appear on serialized, designated form and be in the form prescribed by the Plan Commission.

E. Trial for Civil Subdivision Violations.

1. A person who receives a citation may elect to stand trial for the offence by indicating on the citation his intent to stand trial and returning a copy of the citation to the Building Commissioner. The returned copy of the citation shall serve as notice of the person's intent to stand trial, and additional monetary fines prescribed in this ordinance shall be stayed upon receipt of the notice. On receipt of the notice of intention to stand trial, a lawsuit will be commenced by the Plan Commission Attorney in a court of competent jurisdiction in Jackson County, Indiana. The matter shall be scheduled for trial, and a Summons and Order to Appear shall be served upon the Defendant.
2. If a person who receives a citation fails to pay the assessed fine within 72 hours and fails to give notice of his intention to either file a petition, an appeal, or stand trial as prescribed above, the Plan Commission Attorney may file a civil lawsuit as prescribed by applicable laws and ordinances, and seek penalties as prescribed in this section.

3. A person adjudged to have committed a civil subdivision control violation is liable for the court costs and fees. No cost shall be assessed against the enforcement agency in any such action. Any person who violates this ordinance or fails to comply with any of its requirements shall, upon conviction, thereof be fined \$2,500.00 and, in addition, shall pay all costs and expenses involved in the case, including but not limited to mediation costs, court costs, coverage of reasonable attorney fees, short-term and long-term mitigation of damages, and restoration and restitution. Each day such violation continues shall constitute a separate offense.
4. In proceedings before the court for a civil subdivision control violation, the Indiana Rules of Trial Procedure shall govern. The designated enforcement entity has the burden of proving the civil subdivision control violation by a preponderance of the evidence.
5. Seeking a civil penalty as authorized by this section does not preclude the county from seeking alternative relief from the court in the same action, or from seeking injunctive relief or other remedy in a separate action for the enforcement of this Code.
6. A change of venue from Jackson County shall not be granted in such a case, as provided in IC 36-7-4-1014.

X Definitions & Interpretation

A. Meaning and Intent

All provisions, terms, phrases, and expressions contained in this Ordinance shall be construed according to this Ordinance's stated purpose and intent.

B. Text Controls

In case of any difference of meaning or implication between the text of this Ordinance and any heading, drawing, table, or figure, the text shall control.

C. Lists and Examples

Unless otherwise specifically indicated, lists of items or examples that use terms such as "including," "such as," or similar language are intended to provide examples, not to be exhaustive lists of all possibilities.

D. Computation of Time

Unless the terms of a specific provision state otherwise (e.g., some provisions specify "business days"), periods of time defined by a number of days shall mean a number of consecutive calendar days, including all weekend days, holidays, and other non-business working days; however, if the last day is a Saturday, Sunday, or legal holiday, that day shall be excluded.

E. References to Other Regulations, Publications and Documents

Whenever reference is made to a resolution, ordinance, statute, regulation, or document, that reference shall be construed as referring to the most recent edition of such regulation (as amended), resolution, ordinance, statute, regulation, or document or to the relevant successor document, unless otherwise expressly stated.

F. Public Officials and Agencies

All public officials, bodies, and agencies to which references are made are those of Jackson County, unless otherwise expressly stated. Whenever reference is made to a public official's Ordinance or name of a public agency, that reference shall be construed as referring to the most up-to-date Ordinance or agency name, or to the relevant successor official or agency.

G. Delegation of Authority

Whenever a provision appears requiring the head of a department or another officer or employee of the County to perform an act or duty, that provision shall be construed as authorizing the department head or officer

to delegate the responsibility to subordinates, unless the terms of the provision specify otherwise.

H. Technical and Non-Technical Words

Words and phrases not otherwise defined in this Ordinance shall be construed according to the common and approved usage of the language, but technical words and phrases not otherwise defined in this Ordinance that may have acquired a peculiar and appropriate meaning in law shall be construed and understood according to such meaning.

I. Mandatory and Discretionary Terms

The word "shall" is always mandatory, and the words "may" or "should" are always permissive.

J. Conjunctions

Unless the context clearly suggests the contrary, conjunctions shall be interpreted as follows:

1. *And* indicates that all connected items, conditions, provisions, or events shall apply; and
2. *Or* indicates that one or more of the connected items, conditions, provisions, or events shall apply.

K. Tense and Usage

Words used in one tense (past, present, or future) include all other tenses, unless the context clearly indicates the contrary. The singular shall include the plural, and the plural shall include the singular.

L. Gender

The masculine shall include the feminine, and vice versa.

M. Conservation Subdivision Definitions

For the purposes of **Section VI, Conservation Subdivisions** only, the following definitions apply:

1. **Buffer** means a land area maintained in either a natural or landscaped state and used to visibly separate or screen one use from another or to minimize potentially negative impacts on surrounding areas (e.g., shield or block noise, light or other nuisances, reduce water pollution). Buffer areas may include such things as fences or berms as well as shrubs and trees.
2. **Buildable area** means the land area that does not have any of the following characteristics: wetlands or wetland soils; slopes greater than 25 percent; submerged areas; utility easements; rights-of way, 100 year floodplain; required buffers and required setbacks.

3. **Buildable lot** means the smallest lot area established by the zoning ordinance on which a use or structure may be located in a particular district.
4. **Building envelope** means the area within which clearing, grading, lawns, pavement and buildings will be located.
5. **Conservation easement** means a permanent legal restriction against future development and other activities as specified in the conservation easement deed. An easement may be worded to permit or restrict public access, allow or disallow recreational uses, allow or disallow other uses, such as limited development, agriculture, or forestry. Easements are tied to the title of the land, regardless of subsequent ownership.
6. **Conservation subdivision** means an alternative form of residential development where, instead of subdividing an entire tract into lots of conventional size, a similar number of housing units may be arranged on lots of reduced dimensions.
7. **Construction plan** means the maps or drawings accompanying a subdivision plat and showing the specific location and design of improvements to be installed in the subdivision in accordance with the requirement of the Plan Commission as a condition of the approval of the subdivision plat.
8. **Deed restriction** is synonymous with Restricted Covenant.
9. **Developer** means the owner of land proposed to be subdivided or his representative. Consent shall be required from the legal owners of the property.
10. **Designated open space** means open space that is shown and labeled.
11. **Easement** means the right or privilege that a person may have in another person's property usually for the purposes of installing and maintaining utilities and drainage ways.
12. **Farm/agriculture** means any land, buildings or structures on or in which agriculture and farming operations are carried out as the principal use.
13. **Homeowners association** means a private corporation, association, or other legal entity organized in accordance with state law and established by the developer or the member individuals for the benefit and enjoyment of its members, including oversight and management of common open space or facilities.
14. **Improvement** refers to site grading, streetwork and utilities, including water, sewer, electric, gas and stormwater to be installed or agreed to be installed by the subdivider on land to be used for public or private streets, and easements or other purposes as are necessary for the general use of a lot.

15. **Lot line** means a line or record bounding a lot which divides one lot from another lot or from a public or private street or any other public space.
16. **Open space, common** means land within or related to a development, not individually owned or dedicated for public use, which is designed and intended for the common use or enjoyment of the residents of the development and/or the town and may include such complementary structures and improvements as are necessary, appropriate and approved by the Plan Commission.
17. **Restricted covenant** means a restriction on the use of land usually set forth in the deed for the property.
18. **Sketch plan** means a preparatory sketch to the preliminary subdivision plat layout to enable the subdivider to save time and expense in reaching general agreement with the Plan Commission as to the form of the plat and the objectives of these regulations.

N. Subdivision Control Ordinance Definitions

The following definitions shall apply to the entire Jackson County Subdivision Control Ordinance. If any of the following definitions conflict with the definitions given above, in Subsection L, Conservation Subdivision Ordinance Definitions, the Subdivision Control Ordinance Definitions shall apply, except within **Section VI, Conservation Subdivisions**, where the Conservation Subdivision Ordinance definitions shall apply.

1. **AASHTO** means the American Association of State Highway and Transportation Officials
2. **Access easement** means a private way meeting the standards of this Ordinance that provides access to lots, tracts or parcels of land.
3. **Accessory lot** means a parcel that is not intended to contain a principal use and is permanently tied to another lot that contains or may contain a principle use. An accessory lot must be contiguous to the lot with which it is associated or separated only by a right-of-way.
4. **Alley** means a minor way that provides vehicular access to the back side of property that abuts a street.
5. **Applicant** means the owner or authorized representative thereof of land proposed for subdivision.
6. **As-built plans** means a drawing or drawings accurately indicating the location and design details of all improvements installed in relation to the subdivision.
7. **Block** means property abutting on one side of a street, and lying between the two nearest intersecting or intercepting streets, or between the nearest intersection of an intercepting

- street and railroad right-of-way, waterway or other definite barrier. For purposes of this definition, a cul-de-sac less than 100 feet in length does not constitute an intersecting or intercepting street.
8. **Building line** means a line parallel to the street line touching that part of a building closest to the street.
 9. **Building site** means the three-dimensional space within which a structure is permitted to be built on a lot and that is defined by maximum height regulations, and minimum yard setbacks and is large enough to accommodate the principal structure, any on-site sewage disposal system, and customary accessory structures such as garages, decks, and patios.
 10. **Commission** means the Jackson County Plan Commission.
 11. **Comprehensive Plan** means the complete plan or any of its parts for the development of Jackson County adopted in accordance with the 500 Series of the Indiana Code as is now or may hereafter be in effect.
 12. **Construction plans** means any maps or drawing accompanying a subdivision plat showing the location and design details of improvements to be installed for the subdivision in accordance with the requirements of this Ordinance.
 13. **County Commissioners** means the Board of County Commissioners of Jackson County, Indiana.
 14. **Covenant** means a restriction placed on the development or use of land through a written, recorded instrument.
 15. **Developer** means any individual subdivider, firm, association syndicate, partnership, corporation, trust or any other legal entity commencing proceedings under these regulations to effect a subdivision of land. (See Subdivider)
 16. **Drainage swale** means a natural or constructed waterway, usually broad and shallow, covered with erosion-resistant grasses, used to conduct surface water from a field, diversion or other site feature.
 17. **Drainage system** means any combination of surface and/or subsurface drainage components fulfilling the drainage requirements of this Ordinance.
 18. **Easement** means a grant by the property owner of the use of part of the owner's land by another for a specified purpose.
 19. **Erosion** means the wearing away of the land surface by the action of wind, water or gravity.
 20. **Exempt subdivision** means a subdivision meeting the criteria in this ordinance.
 21. **Floodway** means that area designated as *floodway* on the Jackson County Flood Boundary and Floodway Maps of current adoption promulgated by the Federal Emergency

- Management Agency and the Indiana Department of Natural Resources.
22. **Floodway fringe** means that area designated as floodway fringe on the Jackson County Flood Boundary Maps of current adoption promulgated by the Federal Emergency Management Agency and the Indiana Department of Natural Resources.
 23. **Flood hazard area** means any floodplain, floodway, floodway fringe district or any combination thereof as illustrated on the flood boundary and floodway map prepared by the Federal Emergency Management Agency (FEMA). This is the area immediately affected by floodwater during a "one-hundred-year flood."
 24. **Floodplain** means the floodway and the floodway fringe and any other areas indicated on the Flood Boundary maps as "flood prone areas" for which no data are available. The regulatory floodplain is the area shown as Zone A on the Flood Insurance Rate Map (FIRM). This area includes both the floodway and the fringe portions of the floodplain.
 25. **Flood protection grade** means the following: For residential buildings.
 - a. the elevation of the lowest floor of a building or structure. If a building contains a basement, the basement is considered the lowest floor.
 - b. For commercial and industrial buildings, the water surface elevation for which the building is protected according to standards and specifications established by the Federal Emergency Management Agency.
 26. **IDEM** means the Indiana Department of Environmental Management.
 27. **IDNR** means the Indiana Department of Natural Resources.
 28. **ISDH** means the Indiana State Department of Health.
 29. **Improvement plans** or **drawings** means the maps, drawings and text accompanying a subdivision plat and showing the specific location and design of improvements to be installed in the subdivision in accordance with the requirements of this chapter as a condition of the approval of the plat.
 30. **Landscape screen** means any combination of fences, walls, hedges, shrubs, trees and other landscape materials shown on a plan approved by the plan commission that effectively provide a solid, dense and opaque mass, to prohibit view, absorb sound and provide site delineation. Such screen shall be a minimum of 6' tall and provide total opaqueness throughout the year.
 31. **Legal description** means a property description recognized by law that defines boundaries by reference to government surveys, coordinate systems, or recorded maps and is sufficient to locate property with oral testimony.

32. **Legal lot of record** means a lot created in accordance with applicable regulations that and shown or described on a plat or deed in the Office of the County Recorder.
33. **Lot** means, for the purpose of these regulations, a parcel of land of sufficient size to meet minimum zoning requirements for use, coverage and area and to provide such yards and other open spaces as are herein required. Such lot shall have frontage on a dedicated, maintained public street, approved private street, or access easement.
34. **Lot, double-frontage** means a Lot having frontage on two parallel streets or which fronts upon two streets which do not intersect at the boundaries of the lot.
35. **Lot frontage** means the linear distance of a lot measured at and along the front lot line where the lot abuts a street or other approved access.
36. **Lot width** means the distance between side lot lines as measured at and along the front setback line.
37. **Manual on Uniform Traffic Control Devices** means the book by that title prepared by the Joint Committee on Traffic Control Devices, U.S. Department of Commerce. Bureau of Public Roads, as amended.
38. **Major subdivision** means all subdivisions other than those subdivisions meeting the applicability requirements set forth in this ordinance for minor plats or the definition of "exempt subdivision."
39. **Minor subdivision** means a division of land fronting an existing public right-of-way, not requiring any new streets, alleys, roads or opening of a new public right-of-way and which complies in all other respects with this subdivision control ordinance and the zoning ordinance of the County.
40. **NRCS** means the Natural Resources Conservation Service.
41. **Open space** means any parcel or area of land or water set aside, dedicated, designated, or reserved for public or private use or enjoyment. Open space includes but is not limited to unimproved land, nature preserves, trail systems, and outdoor recreational facilities.
42. **Open space, common** means land within or related to a development, not individually owned or dedicated for public use, that is designed and intended for the common use or enjoyment of the residents and their guests of the development and may include such complementary structures and improvements as are necessary and appropriate.
43. **Owner** (legal title) means the person(s) listed in the most recent official records of the township or county assessor.
44. **Parent tract** or property means the land from which the new lot or tract of land is being taken, as recorded in the recorder's

- office at the time of adoption of this Ordinance. No lot created after the effective date of this Ordinance shall be considered to be a parent tract.
45. **Person** includes an individual, corporation, firm, partnership, association, organization or any other unit or legal entity.
 46. **Petitioner** means the owner(s) of land proposed to be subdivided or his/her representative.
 47. **Plat** means a map indicating the subdivision or resubdivision of land, and intended to be recorded in the Jackson County recorder's plat books.
 48. **Plat committee** means a committee appointed by the Commission to review and act upon minor plats.
 49. **Plat, Final** means a drawing prepared in accordance with the provisions of this ordinance, submitted for Secondary Approval and intended for recording.
 50. **Plat, Minor**. See minor subdivision.
 51. **Plat, Preliminary** means a drawing prepared in accordance with the provisions of this ordinance, submitted for Primary Approval.
 52. **Primary approval** means approval granted by the Commission to a primary plat. The Primary Approval shall include all conditions needed to bring the plat into conformance with this ordinance.
 53. **Principal building** means a building in which the principal use of the lot on which it is located is conducted, including a building that is attached to such a building in a substantial way, such as by a roof (with respect to residential uses, it means the main dwelling).
 54. **Resubdivision or replat** means any change in a map of a recorded subdivision plat affecting any street layout, easement, area reserved for public use, lot line, or affecting any map or plan legally recorded prior to the adoption of any regulations controlling subdivision. A replat shall be considered a minor plat, provided, that no new streets or roads or utility extensions are required. If streets or utility extensions are required, then the plat shall be considered a major subdivision of land.
 55. **Secondary approval** means the final approval granted to a subdivision by the Commission or a designated representative. This approval authorizes the owner or agent to record the plat.
 56. **Setback** means the distance between a building and any lot line.
 57. **Setback line** means the line that is the required minimum distance from any lot line and that establishes the area within which the building or structure must be erected or placed.
 58. **Sketch plan** means a drawing and any accompanying material that shows the general concept of a proposed major

subdivision, including street layout, lot configuration, and such other information as may be required by the Plan Commission's Rules of Procedure.

59. **Street** means a right-of-way dedicated or otherwise legally established for public use, which affords the principal means of access to abutting property. A street may be designated as a highway, thoroughfare, parkway, boulevard, road, avenue, lane, drive or other appropriate name. A street may also be classified according to function as follows:
- a. Expressways are limited-access highways that carry large volumes of traffic and are of more importance regionally than locally. They provide continuous, high-speed traffic flow.
 - b. Arterial streets are high-capacity, high-volume streets that provide access to and through the County. The primary function of these streets is traffic movement, not access to property.
 - c. Collector streets are medium-volume roads that collect and distribute traffic from lower-classification streets to arterials and expressways or activity centers. Traffic movement on these roads is a higher priority than access to property.
 - d. Local streets are low- to-medium-volume streets that have the primary function of providing direct access to property. These streets also distribute traffic to and from arterial and collector streets.
 - e. Cul-de-sac streets are streets with only one outlet and having a paved, usually circular, turn-around at one end.
60. **Street, dead-end** means any street with only one outlet but having no paved turn-around at the closed end.
61. **Street, half** means a street for which only half the required right-of-way is dedicated or improved.
62. **Street, rural** means a street that does not meet the definition of an urban street.
63. **Street, stub** means a street that is extended to the property line for purposes of future extension onto neighboring property.
64. **Street, urban** includes any street located within a subdivision that is:
- a. within the jurisdictional fringe of the City of Seymour;
 - b. adjacent to the corporate limits of any incorporated city or town in the county; or
 - c. has a median lot size that is less than 0.5 acres.
65. **Subdivider** means any person who:
- a. has an interest in land, or

- b. causes it, directly or indirectly, to be subdivided as defined herein, or directly or indirectly, sells, leases or develops or offers to sell, lease or develop, or advertises to sell, lease, or develop, any interest, lot, parcel, site, or unit in a subdivision, or
 - c. engages directly or through an agent in the business of selling, leasing, developing, or offering for sale, lease, or development a subdivision or any interest, lot, parcel, site, or unit in a subdivision, or
 - d. is directly or indirectly controlled by or under direct or indirect common control with any of the foregoing.
(See Developer.)
66. **Subdivision** means the division of a parcel of land into two or more lots, parcels, sites, units, plats or interests for the purpose of offer, sale, lease, or development. It also includes resubdivision or the grant of a right-of-way or access easement.
67. **Subdivision, major.** See Major subdivision.
68. **Subdivision, minor.** See Minor subdivision.
69. **Subdivision, rural** means any subdivision that does not meet the definition of an urban subdivision.
70. **Subdivision, urban** means any subdivision that is:
- a. within the jurisdictional fringe of the City of Seymour;
 - b. adjacent to the corporate limits of any incorporated city or town in the county; or
 - c. has a median lot size that is less than 0.5 acres.
71. **Subsurface drainage** means a system of pipes, tile, conduit or tubing installed beneath the ground surface used to collect ground water from individual parcels, lots or building footings.
72. **Surface drainage** means a system by which the stormwater runoff is conducted to an outlet. This would include the proper grading of parking lots, streets, driveways, yards, etc., so that the stormwater runoff is removed without ponding and flows to a drainage swale, open ditch or a storm sewer.
73. **Thoroughfare plan** (official) means the part of the comprehensive plan, now or hereafter adopted which includes a major street and highway plan and sets the location, alignment, identification, and classification of existing and proposed public streets, highways and other thoroughfares.
74. **Wetland** means those areas where water is at, near, or above the land surface long enough to be capable of supporting aquatic or hydrophytic vegetation and which have soils indicative of wet conditions. The Indiana Wetlands Inventory Maps produced by the Indiana Department of Natural Resources Division of Water will be used as references in determining the size and location of wetlands.
75. **Zone A** means floodplain.

Appendix A -- Certificates & Notations

1. Surveyor certificate.

The following certificate shall appear on all plats:

I, (name) hereby certify that I am a professional land surveyor, licensed in compliance with the laws of the State of Indiana; that, to the best of my knowledge, this plat correctly represents a survey completed by me, or under my direct supervision on (date); that any changes from the description appearing on the last record transfer of the land contained in the secondary plat are so indicated; that all monuments shown thereon actually exist or will be installed (before the release of the financial guarantees) and their position is correctly shown, and, that all dimensional and geodetic data are correct.

(Signature)

(Seal)

2. Owner certificate.

The applicable portions of this certificate shall appear on all plats:

We, the undersigned (names) owners of the real estate shown and described herein, do hereby certify that we plat and subdivide said real estate in accordance with this plat.

The subdivision shall be known and designated as _____, consisting of blocks and containing lots and acres.

All rights-of-way and public lands shown and not heretofore dedicated or deeded to the public are hereby reserved for public use.

Clear title to the land contained in this plat is guaranteed. Any encumbrances and special assessments are explained as follows:

The setback lines shall be determined by the regulations of the Jackson County, Indiana Zoning Ordinance of current adoption.

There are strips of ground shown on this plat and marked easement, reserved for the use of public utilities and subject to the paramount right of the utility or County to install, repair, maintain or replace its installation.

All drainage easements identified on the plat are specifically authorized to be used for drainage purposes. All grades shall be maintained as constructed. Additional cut and fill work within drainage easement areas is prohibited unless authorized by the Jackson County Plan Commission.

WITNESS OUR HANDS AND SEALS this _____
day of 20_____

Before me, the undersigned Notary Public, in and for the County and State, personally appeared
and each separately and severally acknowledged the execution of the foregoing instrument as his or her voluntary act and deed, for the purposes therein expressed.

Witness my hand and Notarial Seal
this _____ day of 20_____

Notary Public (Seal)

3. Primary Approval Certificate.

Plan commission Primary Approval certificate (for all plats, which are approved by the full plan commission).

PRIMARY APPROVAL

Under authority provided by IC 36-7-4-700, Subdivision Control, and any amendments thereto, this plat was given PRIMARY APPROVAL by Jackson County, Indiana, as follows:

Approved by the County Plan Commission at a meeting held
_____, 20____

President

Secretary

Void unless Secondary Approval is received by 20_____

4. Secondary Approval Certificate.

SECONDARY APPROVAL

All conditions of Primary Approval have been met and this plat is granted
SECONDARY APPROVAL.

Approved by the Building Commissioner _____, 20____

Building Commissioner

Void unless Recorded by _____, 20__

5. Plat committee minor plat approval.

PRIMARY APPROVAL

Under authority provided by IC 36-7-4-700. Subdivision Control, and any amendments thereto, this plat was given PRIMARY APPROVAL by Jackson County, Indiana. as follows:

Approved by the Plat Committee at a meeting held _____,
20____.

Chairman

Secretary

Void unless Secondary Approval is received by _____,
20____.

6. Improvement Plans Certificate.

IMPROVEMENT PLANS

This document contains or is a part of the approved improvement plans for the following subdivision: _____.

The improvements to be installed in this subdivision will not be accepted for maintenance by the Board of Public Works and Safety unless and until all improvements shown hereon have been installed and are in substantial compliance with these plans.

County Highway Engineer

Date

7. Dedication Certificate

COUNTY COMMISSIONERS DEDICATION ACCEPTANCE

Be it resolved by the County Commissioners of Jackson County, Indiana,
that the dedications shown on this plat are hereby approved and accepted
this _____ day of _____, 20____ .

Chairman

Attest

8. Tax certificate

The following certificate shall appear on all plats:

TAX CERTIFICATE

The real property has been duly entered for taxation and transferred on the records of the Auditor of Jackson County this _____ day of _____, 20____.

Jackson County Auditor

9. Flood hazard notation.

All plats located within or partially within the flood hazard area shall add the following notation to the owner's certificate:

Minimum flood protection: The minimum flood protection grade in _____ is set at or above _____ feet, M.S.L., which is two (2) feet above the 100-year frequency flood.

The above certificate is not required for administrative plats in Zone A (elevation undetermined); however, the extent of the floodplain as shown on the FIRM or FBFM must still be shown on the plat.

10. Private access easement or street notation.

Those plats containing private access easements or private streets shall add the following notation to the owner's certificate:

This plat contains property shown as private [access easements] [streets].
The responsibility for maintenance and snow removal shall be assumed by the property owners and not by the County.

11. Recording notations.

(a) Recording is hereby authorized by the owners:

(b) Entered for taxation this day of

(c) Recorded in Plat Book _____, page number _____,
this the _____ day of _____, 20____ at _____ O'clock.
Instrument No. _____
Fee Paid

Recorder, Jackson County

(d) Copy of plat received by Assessor

12. Replat notation.

Replats and plat amendments shall contain the following as part of the recording notation:

Notation made on the original plat of _____
Book , Page, Plat

13. Sewage System Covenant

As required the Subdivision Control Ordinance, the covenants applying to any major subdivision utilizing an alternative sewage disposal system shall include the following:

The (Name of Subdivision) Lot Owners Association shall be responsible for the repair, maintenance, improvement, and replacement of the sewage disposal system installed within (Name of Subdivision) pursuant to the provisions of the Subdivision Control Ordinance of Jackson County, Indiana.