

Stark County Metropolitan Sewer District

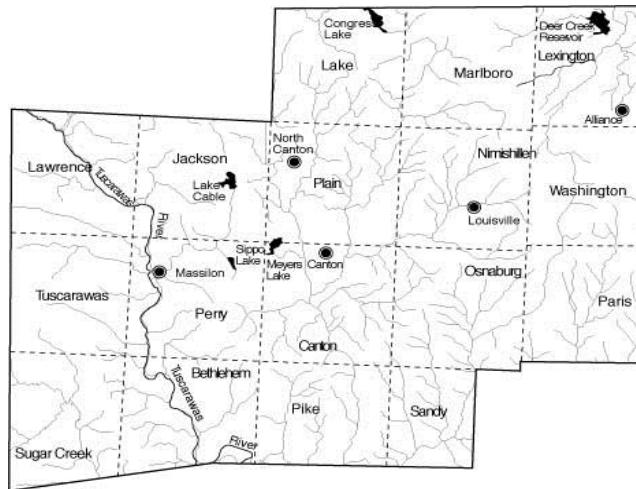

RULES AND REGULATIONS

Stark County Sanitary Engineer

P.O. Box 9972

1701 Mahoning Road N.E.

Canton, Ohio 44711-9972

Phone: 330-451-2303



Email: scse@starkcountyohio.gov

Website: www.se.starkcountyohio.gov

July 2019

STARK COUNTY METROPOLITAN SEWER DISTRICT

RULES AND REGULATIONS

Adopted by Resolution of 10/24/90

Revisions Adopted by Resolution of 1/26/93

Revisions Adopted by Resolution of 10/28/93

Revisions Adopted by Resolution of 5/4/99

Revisions Adopted by Resolution of 3/24/05

Revisions Adopted by Resolution of 8/1/06

Revisions Adopted by Resolution of 11/18/09

Revisions Adopted by Resolution 11/20/13

Revisions Adopted by Resolution 09/09/15

Revisions Adopted by Resolution 07/19/19

TABLE OF CONTENTS

- CHAPTER 1 - Definitions
- CHAPTER 2 - General Conditions
- CHAPTER 3 - Sewage
- CHAPTER 4 - Private Extension of Water/Sewer Lines
- CHAPTER 5 - Procedure for Plan Approval
- CHAPTER 6 - Materials and Specifications
- CHAPTER 7 - Construction
- CHAPTER 8 - Inspection
- CHAPTER 9 - Building Sewers, Water Services and Connections
- CHAPTER 10 - Temporary Wastewater Treatment Plants
- CHAPTER 11 - Sewage Lift Stations
- CHAPTER 12 - Private Sewage Disposal
- CHAPTER 13 - Private Fire Protection Service
- CHAPTER 14 - Razing or Moving Building
- CHAPTER 15 - Disconnection, Connection Freeze, Reconnections
- CHAPTER 16 - Mobile Homes, Trailers, Parks
- CHAPTER 17 - Annexation
- CHAPTER 18 - Drain Layer and Waterline Installer
- CHAPTER 19 - Schedule of Charges
- CHAPTER 20 - Metered Service - Water
- CHAPTER 21 - Backflow Prevention and Cross Connection Control
- CHAPTER 22 – Fats, Oils and Grease Control
- CHAPTER 23 – Oil/Water Separation
- CHAPTER 24 – Outdoor Sanitary Connections
- CHAPTER 25 – Petition Process for Sanitary Sewers

CHAPTER 1

Definitions

- 1.01 Air Gap Separation
Shall mean the unobstructed vertical distance through the free atmosphere between the lowest opening from any pipe or faucet supplying water to a tank, plumbing fixture, or other device and the flood level rim of the receptacle.
- 1.02 Auxiliary Water System
Shall mean any water system on or available to the premises other than the public water system and includes the water supplied by the system. These auxiliary waters may include water from another supplier's public water system; water from a source such as wells, lakes, streams, process fluids or recycled water. They may be polluted, contaminated, and objectionable or constitute a water source or system over which the supplier of water does not have control.
- 1.03 Backflow
Shall mean a flow condition, induced by a differential in pressure that causes the flow of water or other liquids, mixtures or substances into the distribution pipes of a potable water supply from any source or sources other than said potable water supply.
- 1.04 Backflow Prevention Device
Shall mean any device, method, or type of construction intended to prevent backflow into a potable water system.
- 1.05 Board of County Commissioners
Shall mean the duly elected Board of County Commissioners of Stark County, Ohio.
- 1.06 Building Drain
Shall mean that part of the lowest piping of a drainage system which receives the discharge from soil, waste, and other drainage pipes inside the walls of the building and conveys it to the building (house) sewer beginning three (3) feet outside the building wall.
- 1.07 Connection Relief
The temporary cessation of a mandatory abandonment of an existing home sewage treatment system and connection to an installed public sewer.
- 1.08 Connection, Sewer
The point where the service sewer connects to the local sewer.
- 1.09 Connection, Water
Shall mean the connection device at the curb stop used for making the connection of water service lines to the system.
- 1.10 Cooling Water or Industrial Cooling Water
Shall mean water discharged from any system of condensation, air-conditioning cooling, refrigeration or other similar use, which shall be free from odor or oil. It shall not contain polluting substance that will produce B.O.D., or carry suspended solids, in excess of ten milligrams per liter.

- 1.11 County Sanitary Engineer
Shall mean the County Sanitary Engineer appointed by the Board of Stark County Commissioners, or his authorized deputy, agent or representative.
- 1.12 Cross-Connection
Shall mean a physical connection through which a supply of potable water could be contaminated or polluted.
- 1.13 Customer
Any person, including those located outside the jurisdictional limits, who contributes, causes or permits the contribution or discharge of wastewater into the public sewer including persons who contribute such wastewater from mobile sources.
- 1.14 Customer's Water System
Shall mean any water system, located on the customer's premises, supplied by or in any manner connected to a public water system. A household plumbing system is considered to be a customer's water system.
- 1.15 Double Check Valve Assembly
Shall mean an assembly composed of two single, independently acting, check valves including tightly closing shutoff valves located at each end of the assembly and suitable connections for testing the water tightness of each check valve.
- 1.16 Drain Layer
Shall mean a person who has been licensed by the Commissioners to do plumbing work and to install sanitary sewers and connections in accordance with Chapter 18 herein.
- 1.17 District
Shall mean the Metropolitan Sewer District of Stark County that includes all the unincorporated areas of the County and Municipalities by contract.
- 1.18 Easement
Shall mean a grant of a specified use of land by its owner for the installation and maintenance of sewers and waterlines.
- 1.19 Garbage
Shall mean solid wastes from the preparation, cooking and dispensing of food, and from the handling, storage and sale of produce.
- 1.20 Garbage, Properly Shredded
Shall mean the wastes from the preparation, cooking, and dispensing of food that have been separated to such a degree that all particles will be carried freely under the flow conditions normally prevailing in public sewers, with no particle greater than one-half (1/2) inch (1.27 centimeters) in any dimensions.
- 1.21 Inspector
Shall mean the designated employee of Stark County who observes and advises as to the quality of construction as it relates to the regulations and specifications.
- 1.22 Master Plan - Sewer or Master Plan - Water
Shall mean a plan for sewer or water development adopted by the Board of Stark County Commissioners to ensure ultimate development to which all major improvements must conform and as revised from time to time by resolution.

- 1.23 Outfall or Outlet
Shall mean any outlet into a watercourse, pond, ditch, lake, or other body of surface or ground water.
- 1.24 Permit
- 1.24.01 Permit shall mean the permission granted by the Board of County Commissioners for residences, apartments, business buildings or properties, institutions or industrial establishments to connect to a public sewer or water line of the System.
- 1.24.02 Guarantee of Permit shall mean the commitment of the Stark County Sanitary Engineering Department to issue a "Permit" to connect to the public sewer system at the appropriate time. The Guarantee of Permit shall be valid for one calendar year from the date of issue.
- 1.25 Person, Enterprise, Establishment, or Owner
Shall mean any individual, firm, company, association, society, corporation or group.
- 1.26 Potable Water
Shall mean water that does not contain objectionable pollution, contamination, minerals, or infective agents and is considered satisfactory for domestic consumption.
- 1.27 pH
The measure of the relative acidity or alkalinity of water and is defined as the negative logarithm (base 10) of the hydrogen ion concentration.
- 1.28 Private Sewage Disposal System
Shall mean that, where a public Sanitary Sewer is not available, sewage and sanitary drainage piping shall be connected to an individual sewage disposal system found to be adequate and approved by the County Health Department or the Ohio Environmental Protection Agency.
- 1.29 Process Fluids
Shall mean any fluid or solution which may be chemically, biologically or otherwise contaminated or polluted in a form or concentration such as would constitute a health, pollution, or system hazard if introduced into the public or a customer's potable water system. This includes, but is not limited to:
- 1) Polluted or contaminated waters;
 - 2) Process waters;
 - 3) Used waters originating from the public water system, which may have deteriorated in sanitary quality.
 - 4) Cooling waters;
 - 5) Contaminated natural waters taken from wells, lakes, streams, or irrigation systems;
 - 6) Chemicals in solution or suspension;
 - 7) Oils, gases, acids, alkalis, and other liquid and gaseous fluids used in industrial or other processes, or for firefighting purposes.
- 1.30 Reduced Pressure Principle Backflow
Shall mean a device containing a minimum of two independently acting check valves together with an automatically operated pressure differential relief valve located between the two check valves.

During normal flow and at the cessation of normal flow, the pressure between these two checks shall be less than the supply pressure. In case of leakage of either check valve, the differential relief valve, by discharging to the atmosphere, shall operate to maintain the pressure between the check valves at less than the supply pressure. The unit must include tightly closing shutoff valves located at each end of the device and each device shall be fitted with properly located test cocks.

1.31 Service, Water

Shall mean the line running from the system waterline to the user's structure of which the portion from the waterline to and including the curb box shall be owned and maintained by the County and the portion from the curb box to the user's structure shall be owned and maintained by the user.

1.32 Sewage, Sanitary

Shall mean water borne wastes discharging from the sanitary facilities of buildings including, but not limited to, houses, hotels, office buildings, factories or institutions, and being free from storm water, surface water and industrial wastes.

1.33 Sewer Terminology

1.33.01 Sewer shall mean a pipe or conduit for carrying sewage.

1.33.02 Sewer, Building or Lateral shall mean that privately owned and maintained portion of a sanitary sewer serving a single structure from the structure to the service sewer at the road right-of-way or to the local or public sewer in an easement. A private pressure sewer or force main shall be considered a building sewer from the private lift station to the public sewer.

1.33.03 Sewer, Combined shall mean a sewer receiving both surface run-off and sanitary sewage.

1.33.04 Sewer, Interceptor shall mean those sections of the system that intercept sanitary sewage and wastes from trunk or local sewers and that transport such sanitary sewage and wastes to the wastewater treatment plants.

1.33.05 Sewer, Local shall mean those sections of the system, 8-inch in size, that collect sanitary sewage and wastes from service sewers and that transport such sanitary sewage and wastes to the trunk or sub-trunk sewers, said sewers providing service for local service only or individual streets only.

1.33.06 Sewer, Private shall mean a sewer that is not owned by a public authority.

1.33.07 Sewer, Public shall mean a sewer owned or controlled by the Board of Stark County Commissioners in the Metropolitan Sewer District, and does not include the building sewer.

1.33.08 Sewer, Sanitary shall mean a sewer that carries sanitary sewage and wastes and to which storm, surface and groundwater are not intentionally admitted.

1.33.09 Sewer, Service shall mean that public sewer, in the road right of way, from the building sewer (private) to the point of connection with the local or public sewer. In the case where the lateral crosses multiple right of ways, the service sewer shall commence at the right of way of the road containing the local or public sewer.

1.33.10 Sewer, Storm or Storm Drain shall mean a sewer that carries storm and surface waters and drainage, but excludes sanitary sewage and industrial wastes.

- 1.33.11 Sewer, Trunk or Sub-Trunk shall mean those sections of the public sewer system that collect sanitary sewage and wastes from local sewers and that transport such sanitary sewage and wastes to the interceptor sewers.
- 1.33.12 Sanitary Sewer Overflow (SSO) shall mean a spill, release, discharge or diversion of untreated or partially treated wastewater from a sanitary sewer system.
- 1.33.13 Sewage Lift Station shall mean a device designed to pump wastewater from a lower to a higher elevation. The device typically consists of a reservoir to store wastewater and an internal or external pump.
- 1.34 Shall
"Shall" Is mandatory while "may" is permissive
- 1.35 Sludge
Shall mean the accumulated solids separated from liquids, such as water or wastewater, during processing, or deposits on bottoms of streams or other bodies of water.
- 1.36 Suspended Solids
Shall mean solids that either float on the surface of, or are in suspension in water, sewage or other liquids, and which are largely removable by laboratory filtering and as further defined by the current edition of Standard Methods for the Examination of Water and Wastewater.
- 1.37 System Terminology
Shall mean the sewerage or water system as defined below and when the term system is used, it shall be construed to mean the appropriate system as indicated by the context of use.
- 1.37.01 System, semi-public disposal, means a disposal system which treats the sanitary sewage discharged from publicly or privately owned buildings or place of assemblage, entertainment, recreation, education, correction, hospitalization, housing or employment, but does not include a disposal system which treats sewage in amounts of more than twenty-five thousand gallons per day.
- 1.37.02 System, Sanitary Sewerage shall mean all facilities for collecting, pumping, treating and disposing of sanitary sewage in the form of liquid or semiliquid, waste.
- 1.37.03 System, Water shall mean all facilities for production, storage, transmission, distribution, pumping and treatment of potable water.
- 1.38 Tampering
Shall mean any act pertaining to, or use of, the sewerage or water systems of Stark County, which in the opinion of the Sanitary Engineer may endanger the public health, safety or welfare.
- 1.39 Industrial Wastes
Shall mean water-carried and liquid wastes from industrial or commercial processes as distinct from sanitary sewage.
- 1.40 Watercourse
Shall mean a natural channel in which a flow of water occurs, either continuously or intermittently.
- 1.41 Wastewater Treatment Facilities (WWTF)
Shall mean any arrangement of devices and structures used for the treatment of sewage.

1.42 Fats, Oils, and Grease Control Terminology

Definitions listed below primarily refer to Chapter 22 of these regulations.

- 1.42.01 Act: Federal Water Pollution Control Act, also known as the Clean Water Act, as amended, 33 U.S.C. 1251, et. Seq.
- 1.42.02 BOD: The value of the 5-day test for Biochemical Oxygen Demand as described in the latest edition of "Standard Methods for the Examination of Water & Wastewater."
- 1.42.03 COD: The value of the test for Chemical Oxygen Demand as described in the latest edition of "Standard Methods for the Examination of Water & Wastewater."
- 1.42.04 EPA: The United States Environmental Protection Agency, Ohio Environmental Protection Agency (OEPA).
- 1.42.05 Fats, oils, and greases (FOG): Organic polar compounds derived from animal and/or plant sources that contain multiple carbon chain triglyceride molecules. These substances are detectable and measurable using analytical test procedures established in 40 CFR 136, as may be amended from time to time. All are sometimes referred to herein as "grease" or "greases."
- 1.42.06 Generator: Any person who owns or operates a grease trap/grease interceptor, or whose act or process produces a grease trap waste.
- 1.42.07 Grease interceptor: An appurtenance or appliance that is installed in a sanitary drainage system to intercept fats, oils, and grease (FOG) from wastewater. There are two types of grease Interceptors, Gravity Grease Interceptors and Hydromechanical Grease Interceptors.
- 1) Gravity Grease Interceptor: A plumbing appurtenance or appliance that is installed in a sanitary sewage system to intercept fats, oils, and greases (FOG) from a wastewater discharge and is identified by volume, 30-minute retention time, baffle(s), a minimum of two compartments, a minimum total volume of 750 gallons, and gravity separation. These interceptors are designed by a registered professional engineer. Gravity Grease Interceptors are generally installed outside.
 - 2) Hydromechanical Grease Interceptor: A plumbing appurtenance or appliance that is installed in a sanitary sewage system to intercept fats, oils, and greases (FOG) from a wastewater discharge and is identified by flow rate, and separation and retention efficiency. The design incorporates air entrainment, hydro mechanical separation, interior baffling, and/or barriers in combination or separately, and an external flow control, with air intake (vent).
- 1.42.08 Grease Removal Device (GRD): Any hydromechanical grease interceptor that automatically, mechanically removes fats, oils and greases (FOG) from the interceptor, the control of which are either automatic or manually initiated.
- 1.42.09 Grease Waste: Material collected in and from a grease interceptor in the sanitary sewer service line of a commercial, institutional, or industrial food service or processing establishment, including the solids resulting from de-watering processes.
- 1.42.10 FOG Disposal System: A grease interceptor that reduces fats, oils, and grease (FOG) in effluent by separation, and mass and volume reduction.

- 1.42.11 Indirect Discharge or Direct Discharge: The introduction of pollutants directly or from another source or collection system into a Stark County Metropolitan Sewer District collection system or POTW from any non-domestic source.
- 1.42.12 Interference: A discharge, which alone or in conjunction with a discharge or discharges from other sources inhibits or disrupts the POTW, its treatment processes or operations or its sludge processes, use or disposal, or is a cause of violation of the County's NTPDES permit.
- 1.42.13 POTW or Publicly Owned Treatment Works: A wastewater treatment works owned by a state or municipality as defined by section 502(4) of the Clean Water Act. This definition includes devices and systems used in the storage, treatment, recycling and reclamation of municipal sanitary sewage or industrial wastes of a liquid nature.
- 1.42.14 TSS: The value of the test for Total Suspended Solids, as described in the latest edition of "Standard Methods for the Examination of Water & Wastewater."
- 1.42.15 User: Shall have the same meaning as the term "Customer" as defined above. For purposes of these regulations, the terms "Customer" and "User" may be used interchangeably.

End of Chapter

CHAPTER 2

General Conditions

2.01 Authority

The Ohio Revised Code, (O.R.C.) Chapter 6117, empowers the Board of Commissioners of Stark County, to adopt rules and regulations governing policies essential to the operation of the Sanitary Engineering Department under their jurisdiction.

2.02 Jurisdiction

These rules and regulations, as established or amended, shall be applicable to all persons, firms, corporations, partnerships and entities within the Stark County Metropolitan Sewer District.

2.03 Owner and Control

The public sanitary sewerage and water systems of the Stark County Metropolitan Sewer District, including all appurtenances, are under the supervision of the Stark County Sanitary Engineer (Sanitary Engineer) and his authorized employees or agents. Such control shall include all phases and fixtures of the systems from the point of connection as defined in these regulations.

2.04 Illegal Connections

In the event any premises are found to be discharging sewage or other wastes, as defined herein, into the County Sanitary Sewer System without payment of a sewer service charge or rental, or if any premises are illegally connected to the water system by virtue of an unbilled water connection to the County's water distribution system, the Sanitary Engineer shall, by such method as he may find practicable, measure or estimate the quantity of such wastes or water consumption for the purpose of establishing a proper charge in accordance with the schedule of monthly sewer or water service charges, and the said premises shall be charged for the total term of the prior usage on the basis of the quantity so determined. He shall also collect all appropriate other charges as authorized by the O.R.C. and these regulations.

2.05 Access to Private Property

Inspectors or agents of the Stark County Metropolitan Sewer District whose duty requires entrance upon private property or into private premises, in connection with Sanitary Engineering Department business, shall be equipped with proper credentials as the County Sanitary Engineer may deem necessary to identify them as agents of the Sanitary Engineering Department. Such authorized employees shall have access to the premises, at reasonable hours, to examine fixtures and record amounts and manners in which systems are being utilized. Should access be denied these employees for the purposes outlined above, services shall be discontinued and not restored until such a time as access is granted.

2.06 Interpretation

The provisions of these rules and regulations shall be the minimum requirements adopted for the promotion of health, safety, and welfare of the citizens of Stark County, Ohio. These rules and regulations are not intended to repeal, abrogate, annul, or in any manner interfere with any existing laws or rules of any governmental unit that are more stringent. Where these rules and regulations impose greater restrictions than are required by existing laws or rules, then the provisions of these rules and regulations shall take precedence and govern.

2.07 Violation

It shall constitute a violation for any person, firm, group, or corporation, either owner or agent, to tamper with or attempt to use facilities provided by the Stark County Sanitary Engineering Department without first obtaining the necessary permits and approvals. Any permit obtained or approved, based on a false statement made in order to deceive the Stark County Sanitary Engineering Department shall be held void and the applicant shall be held in violation. Any infractions of the rules and regulations set forth by this resolution shall also constitute a violation. Each day shall constitute a separate violation.

2.08 Penalties

Any person, firm, group, or corporation, either owner or agent, committing a violation of this resolution, shall be subject to revocation or suspension of permits or license, and may be deemed guilty of a misdemeanor, and if convicted may be fined as the penalties provide in the Ohio Revised Code. In addition, the violators of these rules and regulations shall be liable and responsible for any and all damages incurred as a result of the violation.

2.09 Validity

Should any section or individual provision of these Rules and Regulations be decided by the courts to be unconstitutional or invalid, such a decision shall not affect the validity of the Rules and Regulations as a whole, or any part thereof, other than the particular portion so held to be unconstitutional or invalid. It is the intention of the authorizing resolution that these rules and regulations are deemed independent one from the other.

2.10 Sanitary Engineer Directives

From time to time the Sanitary Engineer reserves to right to change water or sewer policies that are dynamic and would change more frequently than these Rules and Regulations. These Directives are listed under Water Service Policies and Procedures and Sanitary Sewer Policies and Procedures. These Directives are available by contacting eth Stark County Metropolitan Sewer District and can also be found on the District's website: <https://www.starkcountyohio.gov/sanitary-engineers>.

End of Chapter

CHAPTER 3

Sewage

3.01 Waste to be discharged into Sanitary Sewer

The following are wastes that shall be discharged into the Sanitary Sewer System. All water borne waste from toilets, lavatories, bathtubs, showers, laundry tubs, washing machines, floor drains, refrigeration drips, soda fountains, drinking fountains, and sinks. Any other waste will be permitted only upon written permission of the Stark County Sanitary Engineer.

3.02 Prohibited Wastes

- 3.02.01 No person shall discharge or cause to be discharged the following substances, materials, waters, or wastes to the Sanitary Sewer if it appears likely, in the opinion of the Sanitary Engineer, that such wastes can harm either the sewers, sewage treatment process, or equipment, have an adverse effect on the receiving stream, or can otherwise endanger life, health, public property, or constitute a nuisance. In forming his opinion as to the acceptability of these wastes, the Sanitary Engineer will give consideration to such factors as the quantities of subject wastes in relation to flows and velocities in the sewers, materials of construction of the sewers, nature of the sewage treatment process, capacity of the sewage treatment plant, degree of treatability of wastes in the sewage treatment plant, and other pertinent factors. No person shall discharge any material into any Sanitary Sewer in an amount or concentration deemed illegal by the United States Environmental Protection Agency or the Ohio Department of Health. In the event that the limitations of these organizations are more stringent than those included in the County Sanitary Engineering Department's regulations, the more stringent regulations shall apply. User compliance to the County Sanitary Engineering Department's regulations does not imply compliance to the regulations of any other governing body. The prohibited wastes include:
- 3.02.02 Any storm water, surface water, ground water, subsurface drainage, uncontaminated cooling water, or unpolluted industrial process waters. Storm water and all other unpolluted drainage shall be discharged to such sewers as are specifically designated storm sewers or a natural watercourse.
- 3.02.03 Any waters or wastes having pH lower than 6.0 or higher than 10.0 or having any other corrosive property capable of causing damage or hazard to structures, equipment, and personnel of the sewage works.
- 3.02.04 Any solid or viscous substances in quantities or of such size capable of causing obstruction to the flow in sewers or other interference with the proper operation of sewage works such as, but not limited to, ashes, cinders, sand, mud, straw, metal shavings, glass, rags, feathers, tar, plastics, wood, unground garbage, whole blood, paunch manure, hair and fleshing, entrails, fish cleanings, paper dishes, cups, milk containers, biohazard materials such as; hypodermic needles, syringes, etc., either whole or ground by garbage grinders.

3.02.05 Any waters or wastes containing objectionable or toxic substances; or wastes having a chlorine demand greater than 30 ppm. Toxic wastes discharged into the County Sanitary Sewer System shall not exceed the following limits:

Substance	PPM
Arsenic	4.0
Zinc	8.303
Cyanide	1.00
Copper	1.508
Nickel	2.880
Chromium	3.362
Phenols	5.0
Lead	0.581
Cadmium	0.136
Iron	50.0

Mercury shall not exceed 0.0 ug/L, however, a discharger with a concentration of 0.5 ug/L or less will be considered in compliance as long as the source is known and efforts are being made to eliminate the element.

- 3.02.06 Any waters or wastes containing taste or odor producing substances, in such concentrations as established by the Sanitary Engineer or, which may exceed limits set by State, Federal, or other public agencies having jurisdiction for such discharges to the receiving waters. Any radioactive wastes or isotopes of such half-life or concentration as may exceed limits established by the Sanitary Engineer or applicable State or Federal regulations.
- 3.02.07 Any unusual concentrations or inert suspended solids (such as, but not limited to, Fullers earth, lime slurries, and lime residues) or of dissolved solids (such as, but not limited to, sodium chloride and sodium sulfate).
- 3.02.08 Any excessive discoloration (such as, but not limited to, dye wastes and vegetable tanning solutions).
- 3.02.09 Any waters or wastes which exceed a five (5) day biochemical oxygen demand (BOD) of 300 mg/L or suspended solids of 250 mg/L, or a chemical oxygen demand (COD) of 400 mg/L.
- 3.02.10 Any toxic waste or waters of unusual strength or character which have not been approved for discharge by the Sanitary Engineer
- 3.02.11 Any waters and wastes containing substances, which are not amenable to treatment by reduction by the sewage treatment processes employed, are not to be discharged except by written approval of the Sanitary Engineer. Industrial discharges must meet the requirements of all other governmental agencies having jurisdiction over discharge to the receiving waters.
- 3.02.12 Any liquid or vapor having a temperature higher than one hundred four degrees Fahrenheit (104°F).
- 3.02.13 Any water or waste containing fats, wax, grease, oils, whether emulsified or not, in excess of one hundred (100) mg/L or containing substances which may solidify or become discernibly viscous

at temperatures between thirty two degrees Fahrenheit (32° F) and one hundred fifty degrees Fahrenheit (150°F) (0°C and 65°C).

- 3.02.14 Any garbage that has not been properly shredded. The installation and operation of any garbage grinder equipped with a motor of three-fourths (3/4) horsepower or greater shall be subject to the review and approval of the Sanitary Engineer.
- 3.02.15 Any gasoline, benzene, naphtha, phenols, fuel oil, or other flammable or explosive liquids, solids or gasses.
- 3.02.16 Any other discharge of any material into the Sanitary Sewer determined to be harmful to human or aquatic life or deemed detrimental to efficient operation of the Sanitary Sewer System or POTW, as specified by the Sanitary Engineer.

3.03 Judgment of Waste Quality

- 3.03.01 If any waters or wastes are discharged or are proposed to be discharged to the public sewers, which waters or wastes might contain the substances or possess the characteristics enumerated previously, and which in the judgment of the Sanitary Engineer may have a deleterious effect upon the sewage works, processes, equipment, or receiving waters, or which otherwise create a hazard to life or constitute a public nuisance, the Sanitary Engineer will require the discharge applicant to complete an industrial waste survey questionnaire for the WWTF where the discharge would be treated. The Sanitary Engineer may:
 - 1) Reject the wastes.
 - 2) Require pretreatment to an acceptable condition prior to discharge to the public sewers.
 - 3) Require control over the quantities and rates of discharge, and/or;
 - 4) Require payment to cover the added cost of handling and treating the wastes not covered by existing taxes or sewer charges, as determined by the Sanitary Engineering Department.
 - 5) Require the user to install a sampling unit along the waste stream for the discrete or composite sampling of the users wastewater discharge. Sampling location and structure must conform to the Stark County Metropolitan Sewer District's pretreatment and construction specifications.
- 3.03.02 If the Sanitary Engineer permits the pretreatment or equalization of waste flows, the design and installation of the plants and equipment shall be subject to the review and approval of the Sanitary Engineer, and subject to the requirements of all applicable codes, ordinances, and laws, including the Ohio Environmental Protection Agency, the State Department of Health, and the Army Corps of Engineers.
- 3.03.03 All deviation or waivers from the articles of Section 3.02 shall be approved in writing by the Sanitary Engineer.

3.04 Analysis and Metering

- 3.04.01 All measurements, tests, analyses, of the characteristics of waters and wastes to which reference is made in this resolution, shall be determined in accordance with the latest edition of "Standard

Methods for the Examination of Water and Waste Water", published by the American Public Health Association, and shall be determined at the control manhole provided by the user or upon suitable samples taken at said control manhole. In the event that no special control manhole has been required, the nearest down-stream manhole shall be used to obtain samples for waste quality measurement. Sampling shall be carried out by customarily accepted methods to reflect the effect of constituents upon the sewage works and to determine the existence of hazards to life, health, and property. The particular application involved shall determine the method used to obtain samples. Normally, but not always, BOD and suspended solids analysis and is obtained from twenty-four (24) hour composites of all outfalls, whereas pH's and FOG are usually determined from periodic grab samples.

3.04.02 It is not the intent of any statement contained herein to prevent any special agreement and/or arrangement between the Stark County Sanitary Engineer or Board of Stark County Commissioners and any user of the Sanitary Sewer System whereby a waste of unusual strength or character may be accepted by the County subject to payment therefore by the user.

3.04.03 Any method for cost recovery of charges shall conform to current Federal regulations.

3.05 Special Appurtenances

3.05.01 Grease, oil and sand interceptors shall be provided when, in the opinion of the Sanitary Engineer, they are necessary for the proper handling of liquid wastes containing grease in excessive amounts, or any flammable wastes, sand, or other harmful ingredients; except that such interceptors shall not be required for private living quarters or dwelling units. All interceptors shall be of a type and capacity approved by the Sanitary Engineer and shall be located as to be readily and easily accessible for cleaning and inspection. See Chapter 22 for Fats, Oils and Grease Control and Chapter 23 for Oil/Water Separators.

3.05.02 Preliminary treatment or flow-equalizing facilities provided for any waters or wastes, shall be maintained continuously in satisfactory and effective operation by the owner at his expense. The Stark County Metropolitan Sewer District reserves the right to inspect these facilities.

3.05.03 When required by the Sanitary Engineer, the owner of any property serviced by a Sanitary Sewer carrying industrial wastes shall install a suitable control manhole, together with such necessary meters and other appurtenances to facilitate observations, sampling, and measurement of the wastes. Such control manhole, when required, shall be accessibly and safely located and shall be constructed in accordance with plans approved by the Sanitary Engineer. The control manhole shall be installed by the owner at the owner's expense, and shall be maintained by the owner so as to be safe and accessible at all times.

End of Chapter

CHAPTER 4

Private Extension of Water and Sewer Lines

4.01 Application

- 4.01.01 The private party (hereinafter called the "Applicant") shall file an application with the Stark County Metropolitan Sewer District for the construction of Water and/or Sanitary Sewer Lines, (hereinafter called the "Project") in the District. (Except when the construction is necessary for, and within, an improvement under the Stark County Subdivision Engineer's authority.)
- 4.01.02 Such application shall be made on the form supplied for that purpose by the Stark County Metropolitan Sewer District.
- 4.01.03 The applicant shall submit to the Stark County Metropolitan Sewer District construction plans, drawings, specifications, cost estimates, vehicular traffic plans and such other documents as may be required for the Department's review of the Project.
- 4.01.04 The applicant shall supply the Stark County Metropolitan Sewer District with all easements required for access, operations and maintenance of the lines without charge.
- 4.01.05 Engineering, materials, construction, and testing of the Project shall conform to the County's plans, specifications, standards, rules, and regulations.
- 4.01.06 When the Stark County Sanitary Engineer approves all documents submitted and the foregoing Sections 1 through 5 have been satisfactorily accomplished, he shall so certify his approval by letter to the Stark County Commissioners.
- 4.01.07 The Stark County Commissioners may then grant permission to the Applicant to construct such Project, by Resolution, contingent upon the Applicant entering into an acceptable Contract with the County and fulfilling the requirements of these Rules and Regulations.

4.02 The Contract shall contain

- 4.02.01 Comprehensive General Liability Coverage that shall include Completed Operations --- Products Coverage, Personal Injury Coverage, and Contractual Liability Coverage to satisfy the Indemnification Clause included in the Contract. Explosion, Collapse, and Underground Hazards Liability Coverage shall be included in the General Liability Coverage when occasioned by the contractor's sub-surface operations. Comprehensive Automobile Liability Coverage shall include Non-ownership and Hired Cars Coverage. The minimum limits of liability for all coverages above shall be as follows, unless otherwise specifically required by special provisions in the construction specifications of the Contract:

AMOUNT OF CONTRACT:	UNDER \$50,000	OVER \$50,000 BUT UNDER \$500,000	OVER \$500,000	OVER \$1,000,000
				(1)
Bodily Injury Liability				
Each Person	\$750,000	\$1,000,000	\$2,000,000	
Each Occurrence	\$750,000	\$1,000,000	\$2,000,000	
Aggregate	\$1,000,000	\$2,000,000	\$5,000,000	
Property Damage Liability				
Each Occurrence	\$500,000	\$1,000,000	\$ 1,000,000	
Aggregate (Except Auto)	\$1,000,000	\$3,000,000	\$ 3,000,000	
(1) Special conditions will affect limits to be determined.				

- 4.02.02 The Applicant, his agents and Contractors shall comply with the Ohio Worker's Compensation Act for all of their employees engaged in work under the Contract.
- 4.02.03 The County shall be reimbursed by the Applicant for its inspection costs.
- 4.02.04 The Applicant shall provide a Surety Bond of sufficient amount to compensate the County for completing the entire Project.
- 4.02.05 That upon completion of construction of the said Project and final approval given by the Stark County Metropolitan Sewer District, said lines shall be conveyed to the Stark County Metropolitan Sewer District.
- 4.02.06 That, if requested by the Applicant on his original Application, the County shall collect and return to the Applicant a prorated share of the cost of such improvement in any instance where connection is made to the extension by a non-participant in the original cost of said extension. In order to qualify for reimbursement of the prorated share of construction costs by a non-participant for sanitary sewer, the extension constructed by the applicant must include service sewers to the right-of-way line or easement line abutting the non-participant's property. If the applicant does not provide a service sewer to non-participant properties, then he waives his right to reimbursement for those specific locations. No such condition is required for water service connection to a non-participant. After filing the Application, the Stark County Metropolitan Sewer District shall contact all property owners along the route of the proposed sewer to explain the benefits of participation in the original cost of the extension project. The offer to participate shall be by letter sent by Certified Mail. The property owners so participating shall be identified by name, parcel number and address in the Agreement.
- 4.02.07 That such prorated share for water project extensions shall be based on the sum of the certified costs of the extension divided by the number of parcels with frontage along the water extension project calculated on the day of plan approval by the Sanitary Engineer.
- 4.02.08 That for sewer extensions, such prorated share shall be based on the developed or developable parcel frontage along the extension multiplied by the sum of the certified costs of the extension

divided by twice the total length of the extension as constructed. The prorated share, levied against a non-participant to be reimbursed to the Applicant, shall not exceed the connection charge as referred to in paragraph "d" of the current Stark County Commissioners' Resolution requiring permits for connections, and, for a reimbursement period as stated in 4.02.11, in the event that the above mentioned connection charge be in excess of the calculated prorated share, the connection charge shall be reduced to the amount of the calculated prorated share.

- 4.02.09 For private sanitary sewer and water extension construction completed under Stark County Subdivision Regulations where the Applicant has requested a return of a prorated share of the cost of an extension, the amount to be returned shall be as set forth in Section 4.02.06, Section 4.02.07 and Section 4.02.08 above.
- 4.02.10 That to determine the costs of such project, the Applicant shall provide the Stark County Metropolitan Sewer District with certified copies of all payrolls and invoices for material, supplies, and services used on the extension project.
- 4.02.11 That the County shall return to the Applicant such prorated shares of the cost for a ten (10) year period from the date of the Agreement with the Stark County Commissioners, or until such time as the Applicant has recouped his entire cost of construction, whichever shall occur first.

4.03 Proceeding with the construction of the extension

- 4.03.01 Upon execution of such Contract, the Applicant shall file a copy of the Application and the Contract with the Stark County Auditor and shall pay the fee for each such Application (Contract) filed.
- 4.03.02 A copy of the executed documents required in Section 4.02 shall be filed with the Stark County Metropolitan Sewer District prior to commencement of any construction work.
- 4.03.03 When such Application has been approved, the Contract completely executed and both have been filed with the Stark County Auditor, the Applicant shall be given notice in writing by the Stark County Metropolitan Sewer District that he may proceed with construction of the water and/or sewer extension provided that the applicant has written acceptance for the treatment of the generated wastewater from the wastewater treatment facility along with the approved Permit(s) To Install issued by the Ohio EPA.
- 4.03.04 All construction shall conform to the plans approved by the Stark County Metropolitan Sewer District. The applicant or his agent is required to notify property owners along the route of the improvement at least three (3) days prior to start of construction. Notification will include the name and address of the contractor, contact name and number, schedule of construction and two 24/7 emergency contact names and numbers in which the residents can call. Proof of such notification is to be given to the Stark County Metropolitan Sewer District prior to the start of construction.
- 4.03.05 All construction and testing shall be under the supervision and inspection of the Stark County Metropolitan Sewer District.

4.04 After construction is complete

- 4.04.01 The Applicant's engineer shall provide the Stark County Metropolitan Sewer District with as-built drawings and measurements, consisting of one set of plans along with AUTOCAD compatible

files, both revised in accordance with the results of construction. AUTOCAD files shall be in accordance with Stark County Metropolitan Sewer District specifications and requirements.

- 4.04.02 The costs provided in Section 4.02.03 shall be paid in full before final approval is given to such Project Extension and its use permitted.
- 4.04.03 The applicant shall provide a Maintenance Bond for two (2) years duration in the amount of 5% of the total project cost as a warranty covering the installed sanitary sewer or water extension.
- 4.04.04 The Applicant, his agents and contractors shall waive all rights to place liens against the Extension Project by certifying that they have been paid in full.
- 4.04.05 Final approval of the Extension Project and use of the facility shall be contingent upon the Applicant's satisfactory fulfillment of these Rules and Regulations and the terms of the Contract.
- 4.04.06 After the date of final approval of the Extension Project, the Stark County Metropolitan Sewer District shall collect a prorated share of the cost of such improvement whenever a non-participant connects as provided in Sections 4.02.06, 4.02.07, and 4.02.08, and return such share of payment to the Applicant without a charge for-such service.
- 4.04.07 A non-participant shall not be issued a connection permit until his share of the cost has been paid to the Metropolitan Sewer District.

End of Chapter

CHAPTER 5

Procedure for Plan Approval

5.01 Plan - Physical Format

5.01.01 Standard Sheet: North American Series ANSI D - 22" X 34".

Lettering: All lettering 0.125" high or larger.

Title Block: 6" X 3" located in lower right hand corner.

Include: Sewer district, plat name, section, township, engineer's name, seal, signature, sheet number, number of sheets, and scale.

Revisions Block: 4" X 2-1/2" located directly to left of title block with provision for County Sanitary Engineer to initial any approved revisions.

Scale: Horizontal - 1" = 50' (Preferred)

Vertical - 1" = 5' (Mandatory)

Approval Block located immediately above title block shall include signature lines for:

- 1) County Sanitary Engineer
- 2) The applicable City or Municipal Engineer when connection will discharge to a municipal sewage treatment plant or the lines will occupy the right of way.
- 3) Aqua Ohio for waterlines.

Sheet Numbering Block to be in lower right-hand corner.

5.01.02 A vicinity map shall be provided to show the location of construction.

5.01.03 Each set of plans shall have a cover sheet with a key map showing sheet reference numbers.

5.01.04 Each sheet shall have a readable North arrow oriented up and/or to the right.

5.01.05 Each set of plans shall contain this note: "All sanitary sewers/ waterlines (whichever is applicable) and appurtenances shall be constructed according to Stark County Sanitary Engineering Department Specifications, in effect at time of construction."

5.01.06 Profiles for sewer/waterlines shall be shown on the same sheet as the plan. The profile shall be below the plan and shall be taken at the pipe invert. The profile shall be lined up under corresponding points on the plan. The existing and proposed grade profile shall be shown on each profile view.

5.01.07 All existing structures in the street or easement shall be shown in both plan and profile. Sizes, location, dimensions, and elevations shall be included. These structures include (but are not limited to):

- 1) Gas mains
- 2) Electric and telephone conduits
- 3) Storm sewers
- 4) Sanitary sewer line
- 5) Water lines
- 6) All other underground obstacles
- 7) Telephone poles
- 8) Electrical power poles
- 9) Street lights
- 10) All above ground structures which may affect construction

5.01.08 Manholes (and/or hydrants) shall be consecutively numbered and, for manholes, from lowest to highest elevation and station numbers shall be noted. Manhole #1 shall be the manhole next upstream when connecting to an existing manhole. Both manhole (or hydrant) and station numbers shall appear on both plan and profile. The length, grade, and size of each span of sewer shall appear on the plan and profile.

The type of pipe material, the diameter, slopes, joints, and strength shall be shown on the profile.

The location of all special features such as concrete or steel pipe encasements, siphons, elevated sewers, special cross sections, fittings, and valves shall be shown.

Details of all special appurtenances such as manholes, inspection chambers, siphons, regulators, metering devices, elevated sewers, anchors, valves, tees and bends, etc., shall be shown.

5.01.09 All subdivisions and Plat Book page shall be clearly marked including lot numbers. All properties abutting the improvement shall be shown for full width and depth.

The ownership of all property ~~not subdivided by a recorded plat~~ shall be shown on the plan, including instrument number, Deed Book, page, acreage and permanent parcel number.

All corporation lines with dimensions and other information that will fix the exact location shall be shown. Section, Township, and Range numbers shall be included.

The location, description, elevation, and tie lines of all bench marks used in connection with the project shall appear on each appropriate sheet.

Test borings shall be located where made and the date of boring shall be shown.

All survey measurements shall be in **state plane coordinates**. In accordance with the specifications and standards of the Stark County Auditor and Engineer.

Proposed sewer or water lines shall be shown as solid dark lines.

Existing lines shall be shown as dashed lines.

Existing or proposed streets and all streams or water surfaces shall be clearly shown.

All stream crossings shall be shown with streambed elevation.

5.01.10 All service sewers shall extend to the property line in the case of public projects and fifteen (15) feet inside the property line if constructed as part of a new subdivision.

5.01.11 The Stark County Sanitary Engineer's approval is subject to conditions imposed by the Ohio Environmental Protection Agency.

5.02 Sanitary Sewer Service Requests

5.02.01 A professional engineer, registered in Ohio, shall submit a preliminary plan showing lot layout and overall sewer collection plan.

5.02.02 The availability of service for the area for the use intended shall be determined by the Sanitary Engineering Department.

5.02.03 Oversize facilities as required by the Master Plan and/or the facility plans on file shall be determined by the Stark County Metropolitan Sewer District.

5.03 Revisions

Any deviation from approved plans and specifications affecting capacity, flow, or operation of units or any other such basic design change shall be approved before such changes are made. These revisions, not included on approved plans, shall be submitted well in advance of construction. "As-built" drawings clearly showing such changes shall be submitted at the completion of the work.

5.04 Construction Plans - Approval Period

Approved plans are only valid for one year. After one year, they must be resubmitted for re-approval.

5.05 Construction Plans - As-Built Drawings

5.05.01 As-built distances must not have any objects, dimensions, elevations, grades, etc., crossed out they must be erased from the drawing. Flowline, pipe grades and top of casting elevations, distances between manholes and manhole deflection angles are required.

Plugged ends of sanitary sewer lines must be located.

All as-built dimensions are to be measured in feet and tenths of a foot.

- 1) Dimension lines shall be shown on drawing except where they would add substantial confusion in interpretation. Written dimensions with an arrow pointing to the item being referred to will then be acceptable.

- 2) Dimensions shall be from centerline to centerline except for house corners and catch basins.
- 3) Written dimensions will be considered at right angles with one another unless noted or shown otherwise.
- 4) Measurements shall be on the horizontal unless noted under special circumstances.

Abbreviations will be accepted for the following:

Sanitary Manholes	San. M.H.
Catch Basin	C.B.
Curb	C.
Fire Hydrant	F. Hyd.
Directions	N, S, E, W
Telephone Pole	T. P.
Power Pole	P. P.

5.05.02 The following will be required on all “As-Built” Drawings:

- 1) Distances between sanitary manholes and between sanitary manholes and the plugged end of the line are to be shown on the plan. All distances shall be shown from center of manhole to center of manhole.
- 2) Length of span, grade, size and type of pipe, rim and invert elevations will be required in the profile.
- 3) Length of span may vary $\pm 0.5'$ before manhole location in profile must be changed. The dimension, however, must be marked clearly and correctly.
- 4) Invert elevations may vary $\pm 0.5'$ before main line in profile must be changed. The elevations, however, must be marked clearly and correctly.

5.05.03 The following is a list of objects that will be acceptable for “As-Built” dimensions references:

- 1) Fire Hydrant
- 2) Curb
 - a) All curb dimensions must be to the back of the curb and must not be to any curb or extended curb lines with a radius.
- 3) Catch Basin
 - a) Dimensions are to be to the nearest corner of the steel edge on the street side.
 - b) The street and/or corner on which the catch basin is located must be indicated.
- 4) Sanitary Manholes and/or Storm Sewer Manholes
- 5) Utility pole, if it is to be permanent.
 - a) When a dimension to a utility pole is used, the description and number of the pole must be given.
- 6) House Corner
 - a) When a dimension to a house corner is used, the address must be given.

- 7) Corner of a paved drive.
 - a) House number must be given.

5.05.04 As-built drawing submittals shall include one set of plans and AUTOCAD compatible file formats on suitable media for use with Windows operating system, in accordance with Stark County Sanitary Engineering Department requirements. In accordance with the specifications and standards of the Stark County Auditor and Engineer.

5.06 Available Capacity
 All proposed connections to existing Stark County Sanitary Sewer Systems shall include a review of the receiving sewer system to determine the effect of the proposed connection on a hydraulic capacity of the receiving sewer system. The review should include: the average daily flow at full buildout using Stark County’s Single Family Equivalent System; the peak flow using the OEPA’s “Greenbook” peak flow calculation; and the impact to the downstream collection system.

5.07 County Ownership
 Upon acceptance by the Stark County Sanitary Engineering Department, all sewerage or water facilities constructed by any person, firm, or corporation, shall be owned, operated, and maintained by Stark County Metropolitan Sewer District.

5.08 Easements
 When easements are required, they must be filed with the County Recorder's Office and a copy of the recorded document provided to the Sanitary Engineer before final approval of the project the notice to proceed is issued.

5.09 Submission of Plans

5.09.01 The number of sets of plans to be submitted for review and approval shall be in accordance with the following schedule:

	<u>No. of Sets</u>
Sanitary Sewer Only	4 2
Sanitary sewer w/pump station	2-3
Waterline only	2
Sanitary sewer and waterline	2
Sanitary sewer w/pump station & waterline	3

5.09.02 For the number of sets approved and signed plans to be submitted, add four (4) to the quantities noted in Sec. 5.09.01 above for the pre-construction meeting. A cover sheet shall be provided for all plans.

5.09.03 Once approvals from all applicable agencies have been obtained, plans shall be provided in AUTOCAD 2012 or later compatible file formats on suitable media for use with the most current Microsoft operating system, and in accordance with Stark County Sanitary Engineering Department requirements. In accordance with the specifications and standards of the Stark County Auditor and Engineer.

End of Chapter

CHAPTER 6

Materials and Specifications

6.01 Requirements

Materials used in the construction of private or public sanitary sewer or water facilities shall be equivalent to, or exceed, the materials and specifications approved by the Board of Stark County Commissioners now on file at the Stark County Sanitary Sewer District or as hereafter amended.

End of Chapter

CHAPTER 7

Construction

7.01 Requirements

Construction of any sewerage or water facilities that are to be owned and operated by the Stark County Metropolitan Sewer District shall be inspected by and meet the requirements of the Stark County Sanitary Engineering Department.

End of Chapter

CHAPTER 8

Inspection

8.01 Jurisdiction

Any and all connections to the Stark County Metropolitan Sewer District's sanitary sewer and/or water distribution systems shall be inspected by and subject to testing under the supervision of the Stark County Sanitary Engineer or his designated representatives.

8.02 Fees

The cost of all inspection performed by the Stark County Sanitary Engineering Department shall be at a rate established by the Board of Stark County Commissioners and shall be borne by the owner responsible for the construction. Said owner is required to deposit with the Stark County Sanitary Engineering Department a sum of money, payable to the Stark County Treasurer, in an amount to be determined by the Stark County Sanitary Engineer for each application, before any construction can commence. The Stark County Sanitary Engineer will require additional deposits to this fund if the original deposit proves inadequate.

When the Stark County Sanitary Engineering Department certifies that no further field **inspection**/engineering services are required for the improvement, the Stark County Sanitary Engineer will prepare a voucher in favor of the Depositor refunding any balance remaining in his account.

8.03 Acceptance

No sewer or water improvements shall be transferred to the Stark County Metropolitan Sewer District until a written acceptance is received by the owner(s) from the Stark County Metropolitan Sewer District.

8.04 Notification of Start of Construction

8.04.01 The owner shall give forty eight (48) hours' notice to the Sanitary Engineer's Inspection Division prior to the commencement of work. Notification of stoppage of work must also be given. However, the inspection division retains the right to defer the requested starting schedule to a later date.

- 1) After the purchase of the sewer permit application and prior to the connection of a building to the sanitary sewer, an inspection of the existing plumbing configuration must be completed by the Stark County Sanitary Engineering Department for compliance with the Rules and Regulations of the Sanitary Engineer's Office. Upon completion of inspection, the owner will be notified of any necessary changes required prior to the actual connection of the building to sanitary sewer. In such case, the owner will be advised by the inspector in order to arrange for a final inspection. The owner shall give a minimum of twenty-four (24) hours' notice to the Permits Department for the purpose of scheduling both the initial and final inspection.

8.04.02 All work must be completed in the presence and with the approval of the Stark County Sanitary Engineering Department.

8.04.03 All materials and workmanship in connection with any building sewer line or water service to a structure shall conform to the Specifications of the Stark County Sanitary Engineering Department as now in force or hereafter amended.

- 8.04.04 No connection shall be made to any sewer or water line without a permit from the Stark County Sanitary Engineering Department.
- 8.04.05 If the Sanitary Engineer deems that any work is progressing improperly, he may order all work stopped. Work shall not resume without permission from the Sanitary Engineer or his Agent.
- 8.04.06 If any change or modification of the plan is deemed necessary during construction, the Sanitary Engineer shall determine if such change or modification must be resubmitted for approval and revised on the plans.
- 8.04.07 All work and materials shall adhere to the Specifications of the Stark County Sanitary Engineering Department in effect at the time of construction.
- 8.04.08 If any plumber, contractor, drain layer, or waterline installer shall neglect or refuse to abide by these Rules and Regulations, the County Sanitary Engineer may cause such work to be done and charge said plumber, contractor, drain layer, or waterline installer for payment of such work. These matters shall be considered in issuing further permits and may result in the possible suspension, revocation, or non-renewal of drain layers or waterline installers' licenses, and may be considered when awarding future projects to the plumber, contractor, drain layer, or waterline installer.
- 8.04.09 No provision in this article shall be so construed as to relieve a person, firm, or corporation of furnishing all private engineering services necessary in connection with the improvements.

8.05 Testing

- 8.05.01 All work done under the authority of the Stark County Metropolitan Sewer District shall be tested in accordance with the Stark County Metropolitan Sewer District's specifications and found acceptable before the work may be placed into service.
- 8.05.02 All testing must be done in the presence of an inspector of the Stark County Sanitary Engineering Department.
- 8.05.03 All sanitary sewers and manholes must be tested per the Stark County Sanitary Engineering Department's current Specifications for Sewer Line Construction.
- 8.05.04 All waterlines must be pressure tested and disinfected in accordance with current specifications.
- 8.05.05 All non-rigid sanitary sewers of 8-inch diameter and greater shall be mandrel tested. This test shall occur a minimum of 30 days after backfill over the sewer has been completed.
- 8.05.06 All sanitary sewers 8" diameter or larger must pass internal television inspection. The contractor shall provide complete internal inspection video to the Sanitary Engineering Department. The videotaping procedure must be in accordance with Stark County Sanitary Engineering Department specifications. Videotaping of newly installed sanitary sewers shall occur a minimum of thirty (30) days after backfill over the sewer has been completed.

End of Chapter

CHAPTER 9

Building Sewers, Water Services, and Connections

9.01 Authorization

9.01.01 No unauthorized person shall uncover, make any connection with, construct an opening into, use, alter or disturb a public or private sanitary sewer manhole, flowmeter, waterline, valve or hydrant without first obtaining a permit for connection from the Stark County Sanitary Metropolitan Sewer District.

9.02 Requirements - Sewer

9.02.01 A separate and independent lateral (building/service) sewer shall be provided for each separate building. The minimum pipe size shall be six (6) inches unless the existing building/service sewer is smaller. The minimum depth at the building shall either clear the building footers or intercept the septic system, whichever is deeper.

9.02.02 The building sewer shall be constructed using the pipe size and material that meets the current specifications of the Stark County Sanitary Engineering Department. It shall be laid at a grade no less than one (1.0) foot vertical per one hundred lineal feet for a six (6) inch sewer, from the building to the public sewer. A building sewer with a diameter larger than six (6) inches shall be laid at a grade no less than the minimum grade permitted by the specifications of the Stark County Sanitary Engineering Department for the given diameter. The building sewer connection to the building drain shall be made at a point within three feet of the building foundation.

9.02.03 The owner of the premises served by a sewer shall be responsible for the operation and cleaning of the building sewer and service sewer. The repair and reconstruction of the building sewer will be the responsibility of the owner. In the case of gravity services, repair and reconstruction of the service sewer shall be the responsibility of the Stark County Metropolitan Sewer District. In the case where sewer services are pressure lines, the property owner shall be responsible for repair and reconstruction from the property line to the point of connection with the local sewer.

9.02.04 Service sewers constructed as part of new subdivisions shall be installed to a minimum of fifteen (15) feet inside the property line of each lot.

9.02.05 When a new connection into the main sewer line is made, a new wye must be placed in the mainline for 8" sewers. For larger diameter mains, saddles, or taps may be used upon approval by the Sanitary Engineer. Permission to tap any sanitary sewer line must be given by the Sanitary Engineer. Work will be completed under the inspection of the Stark County Sanitary Engineer.

9.02.06 If a service sewer is to be installed where any portion of the sewer must pass through property not owned by an applicant, the applicant must assume full responsibility for acquiring the right to pass through such property. The applicant shall submit a proposed easement document (unsigned) to the Sanitary Engineer for preliminary review. Once the easement is approved, by the Stark County Sanitary Engineer and signed by the pertinent landowners, the applicant shall provide the Sanitary Engineer with a copy of the signed and recorded document prior to a permit being issued.

9.02.07 When the building sewer installation occurs in advance of or at the same time as the building excavation (early sanitary sewer connection), but before construction of footers, supplemental

requirements shall be established by the Stark County Sanitary Engineer for said installation. In no case shall a sanitary building sewer be used to drain water from any excavation. Utilizing the sanitary sewer to drain an excavation may result in enforcement action against the drain layer up to and including revocation of the drain layers license.

- 9.02.08 All buildings connecting to the sanitary sewer system shall provide at least one full-sized vent equal in diameter to the building drain but not less than three inches for a building drain three inches or larger.
- 9.02.09 The use of air admittance valves shall be prohibited if the plumbing system is connected to the County sanitary sewer system.

9.03 Requirements - Water

- 9.03.01 When an application is made for the installation of a County service line or for water service or for the reinstatement of water service, the County shall be entitled to assume that the piping and fixtures to which the service will be supplied are in good order to receive such service but reserves the right to inspect said facilities to assure against possible damage and cross connections (See Chapter 21). Water will not be furnished where pipes are inferior, the plumbing is defective, or the faucets, water closets or other fixtures leak or are not in good working order. When such conditions are discovered, the supply of water may be shut off until repairs are made. The County, at its discretion, will periodically conduct leak surveys of the system in order to enforce this provision.
- 9.03.02 In addition to provisions included in this chapter, supplemental requirements entitled *Water Service Policies and Procedures* are in effect and will be provided.
- 9.03.03 The County cannot guarantee the customer a specific or continuous pressure, nor does it guarantee the water delivered as to quality, purity or temperature. These variables are subject to conditions that may arise in the supply operation and/or maintenance of the system at any given time.
- 9.03.04 The County shall have the sole right to determine the size, type and location of meters, meter settings, valves, service lines, and connections necessary to provide the service applied for. Exclusive operating control of all service lines from main to meter and of meter installations shall at all times remain with the County and shall not be interfered with in any respect. Section 9.03.09 provides for customer responsibilities.
- 9.03.05 The County will be responsible for tapping or making any connection with the mains or distribution pipes. All services between the main and the point of connection near the property line, including the curb stop and curb box, will be installed by the County except in such cases where the County allows others to do so by prior approval.
- 9.03.06 The customer shall not, without County consent, use water for any purpose, building or upon any premises not stated in the application for service.
- 9.03.07 The application for the installation of a County service line must state the uses for which the water is to be applied and the correct parcel and street number or other complete identification of the premises to be supplied. The application for installation of a County service line will be accepted subject to the condition that there shall exist, adjacent to the premises to be served, a supply of water sufficient to provide the service requested. A service line may not be used to

supply more than one premises or building unless specifically granted permission to do so by the Stark County Metropolitan Sewer District.

- 9.03.08 Service lines shall be installed to provide for inside meter settings except in special cases where the County has approved outside meter settings. The curb stop or outside meter vault shall be installed at a place designated by the County between the curb line and the property line. Curb stops or valves in the County's service lines are for the exclusive use and under the exclusive control of the County.
- 9.03.09 The customer shall, at his expense, install, maintain and repair the customer service line, which is that portion from the curb stop to his structure. When a leak in a customer service line is discovered, the County may turn off the water service until the leak is repaired. Without limiting the authority of the County under the preceding sentence, the County will endeavor, when the circumstances are such as to make it practicable, to give notice to the customer before discontinuing such service in order to afford him a reasonable time to make such repairs.
- 9.03.10 In case of breaks in mains, services, pumps or other water facility equipment, and for the purpose of tapping, extending, repairing, replacing or cleaning mains, water may be shut off to customers without giving prior notice.
- 9.03.11 When any premises are supplied with water from two or more standard services, which originate from different supply systems, such services must be provided with double check valves so that water can flow into the premises but cannot flow out through either of the services. See Chapter 21 for specific detail about backflow prevention devices.
- 9.03.12 The customer service line shall be laid at a minimum depth of four (4) feet below ground level. The service line shall be not less than 1-inch nominal size and shall be either "Type K" copper tubing or other County-approved water pipe. Solder-free joints shall be used on the service line from the water main to the valve located downstream of the water meter.
- 9.03.13 If a service line is to be installed where any portion of the line must pass through a property not owned by an applicant, the applicant must assume full responsibility for acquiring the right to pass through such property. The applicant shall submit a proposed easement document (unsigned) to the Sanitary Engineer for preliminary review. Once the easement is approved, by the Stark County Sanitary Engineer and signed by the pertinent landowners, the applicant shall provide the Sanitary Engineer with a copy of the signed and recorded document prior to a permit being issued.
- 9.03.14 The customer service line may be laid in a separate trench or, under special circumstances and with the approval of the Sanitary Engineer, may be laid on a ledge on either side of the sewer trench. Said ledge shall be cut into the side of the sewer trench so as to provide a shelf six (6) inches wide of solid firm soil for the entire length of the pipe. The water service line should be laid above the sewer line a minimum vertical separation of 18" measured from its outside invert to the outside crown of the sewer. The applicant shall leave the trench open and pipe uncovered until it is inspected and approved by the Sanitary Engineer.
- 9.03.15 When the installation of a customer line has been completed, the customer shall leave the service line turned off until final inspections have been completed.

9.04 Permits

- 9.04.01 Permits to connect to, open, or alter any public sanitary sewer or appurtenance or to install a customer waterline will be issued only to a valid Drain Layers Licensee of the Stark County Sanitary Engineering Department. In the case of waterline installation, the installer must provide evidence of registration with the Stark County Health Department. Where a customer installs their own waterline, permits will be issued to the customer.
- 9.04.02 The person, firm, or corporation to whom a permit is issued, will be held responsible for the proper installation of the building sewer or the waterline in accordance with these Rules and Regulations. The County of Stark, its officers, and agents shall be held harmless from any loss or damage associated with said installation.
- 9.04.03 The person, firm, or corporation to whom a permit is issued, shall be responsible for obtaining any required permits to open cut or bore under any street, road or highway, from the appropriate political body or official having jurisdiction over such street, road, or highway and shall comply with all conditions required by such permits.
- 9.04.04 Permits for uses other than single family residences shall not be issued without the approval of the building/civil plans by the Sanitary Engineer. Two full size copies of the development plans, prepared in accordance with Chapter 5 of these Rules and Regulations, shall be provided for review.

End of Chapter

CHAPTER 10

Temporary Wastewater Treatment Plants

10.01 Requirements

- 10.01.01 All persons shall be required to enter an agreement with the Stark County Commissioners for the development of any land in the Stark County Metropolitan Sewer District, which generates a sewage flow where a central receiving sewer is not available and a Temporary Wastewater Treatment Plant is to be installed. (Copies of the agreements are available in the offices of the Stark County Sanitary Engineering Department). Authority to install a Temporary Wastewater Treatment Plant must be obtained from both Stark County and the Ohio Environmental Protection Agency. The Stark County Commissioners will decide whether to enter into an agreement at their discretion.
- 10.01.02 Plant design and installation shall be subject to such requirements as the Stark County Sanitary Engineer and the Ohio Environmental Protection Agency requires, based upon locale, degree of treatment, safety, layout, auxiliary equipment required for proper operation and maintenance, access, and any other items required.

End of Chapter

CHAPTER 11

Sewage Lift Stations

11.01 Requirements

- 11.01.01 Lift stations shall not be permitted unless specifically approved by the Stark County Sanitary Engineer.
- 11.01.02 Sewage lift stations shall comply in all respects with the requirements of the Stark County Sanitary Engineer and/or the Ohio Environmental Protection Agency based on safety, layout, access, auxiliary equipment required for proper operation and maintenance, or any other item peculiar to that station which may be required in the judgement of the County Sanitary Engineer and/or the Ohio Environmental Protection Agency.
- 11.01.03 Installation of private lift stations shall be at the approval of the Stark County Sanitary Engineer. All private lift stations shall remain the property of the owner and shall be operated, maintained and replaced by the owner at owner's expense.
- 11.01.04 Developers requesting permission to install lift stations and pressure sewer mains shall submit a written request to the Sanitary Engineer for approval prior to completing preliminary plans and specifications. In addition to the written request, the developer shall submit a fifty (50) year cost effectiveness analysis comparing the cost of installation and operation and maintenance of gravity sewer mains/appurtenances and lift station/ pressure sewer mains/appurtenances if the County's general plan for the street/area does not specify pressure sewers. The study shall be completed by a professional engineer registered in the State of Ohio. If the study is approved by the Sanitary Engineer, the developer may continue the design of the lift station and pressure mains.

End of Chapter

CHAPTER 12

Private Sewage Disposal

12.01 Requirements

- 12.01.01 Where a public sanitary sewer is not available, the building sewer shall be connected to a household sewage treatment system (HSTS), small flow on-site sewage treatment system (SFOSTS) or a semi-public sewage disposal system complying with the rules and regulations of the Board of Health of the Stark County Combined General Health District (elsewhere herein, Health Department). Semi-public sewage disposal systems must comply with the Ohio EPA rules and policies.
- 12.01.02 The owner shall, at his own expense, operate and maintain a HSTS, SFOSTS or a semi-public sewage disposal facility in a sanitary manner at all times and to the satisfaction of the Stark County Health Department and/or Ohio EPA.
- 12.01.03 It shall be unlawful for any HSTS, SFOSTS or semi-public sewage disposal facility to be connected to any public sanitary, storm or combined sewer.

12.02 Connection to a Public Sewer

- 12.02.01 When a public sanitary or combined sewer becomes available to a property served by a HSTS, SFOSTS or semi-public sewage disposal system, a direct connection shall be made thereto, by and at the expense of the owner, in compliance with these Rules and Regulations and the rules and regulations of the Health Department. HSTS, SFOSTS or semi-public sewage disposal facilities shall be abandoned by a licensed drain layer in accordance with the Health Department's sewage treatment regulations within 14 days of connection to a sanitary sewer system.
- 12.02.02 Within 30 days of the date that the owner of a property served by an eligible HSTS, SFOSTS, or semi-public sewage disposal system receives notification that the collection system is available for connection, the owner may choose to submit a written request for connection deferment to the Sanitary Engineer. The Sanitary Engineer and Health Department will examine the request for eligibility and, if conditions warrant, the requirement to connect to the sanitary sewer may be deferred for a reasonable time not less than 2 years and not more than 10 years.
- 12.02.03 The Sanitary Engineer and Health Department will use the following guidelines in evaluating eligibility for the deferment:
- 1) A public sewer that becomes available to a property treating wastewater by a NPDES discharging type HSTS may be relieved of connecting to the public system until the HSTS is no more than five (5) years in age from the date of its approval by the Health Department at installation, provided it is operated in accordance with applicable State and County Laws and Regulations. The deferment of five (5) years will be counted from the time of system installation approval and not when the public sewer becomes available. However, if less than two years remain on the five (5) year period when

sewer becomes available, the property owner may be relieved for two (2) years. Any system not operated in accordance with the law or that creates a public health nuisance shall forfeit the deferment.

- 2) A public sewer that becomes available to a property treating wastewater by a non-discharging, soil absorption type HSTS may be relieved of connecting to the public system until the HSTS is no more than ten (10) years in age from the date of its approval by the Health Department at installation, provided it is operated in accordance with applicable State and County Laws and Regulations. The deferment of ten (10) years would start at the time of system installation approval and not when the public sewer becomes available. However, if less than two years remain on the ten (10) year period when sewer becomes available, the property owner may be relieved for two (2) years. Any system not operated in accordance with the law or that creates a public health nuisance shall forfeit the deferment.

12.02.04 Eligibility for deferment will be determined by the Sanitary Engineer, in consultation with the Health Department and may be declined based on the factors listed below:

- 1) The system is creating a public health nuisance as defined by the Ohio Revised Code 3718.
- 2) The system has not been operated in accordance with Ohio Sewage Treatment System Regulation, Ohio Revised Code 3718 and Ohio Administrative Code, Chapter 3701-29.

12.02.05 Properties for which deferment is declined or any system for which connection has been deferred and is not operated in accordance with the law or that creates a public health nuisance shall have the deferment revoked and be referred to the Health Department for immediate enforcement of the requirement to connect to the sanitary sewer.

12.02.06 Any property for which connection has been deferred, upon conveyance to a new owner, shall be connected to the sewer within sixty (60) days of the conveyance or sixty (60) days of possession, whichever is later.

12.03 Disposal of Septic Tank and Holding Tank Wastes

12.03.01 No person, firm, or corporation shall discharge septic tank or holding tank wastes into any water course or storm sewer.

12.03.02 No person, firm, or corporation shall discharge septic tank or holding tank wastes into any manhole or other appurtenance of any sewer which discharges either directly or indirectly into the sewage facilities of the Stark County Metropolitan Sewer District.

End of Chapter

CHAPTER 13

Private Fire Protection Service

13.01 Private Fire Protection

13.01.01

Private fire protection service includes, but is not necessarily limited to, water service to a customer's fire protection facilities such as sprinkler systems and/or fire hose connections in buildings and structures and fire hydrants other than those which qualify as public fire hydrants and are operated and maintained by the County.

13.01.02

Where a customer desires both regular water service and water service to fire protection facilities on his premises which require either or both the service line and the meter to be of a larger size or of a different type than would be approved by the County for supplying and measuring the regular water service, the fire protection service shall be supplied only through a separate service line.

13.01.03

An application for private fire protection service will be accepted subject to the condition that there shall exist, adjacent to the premises to be served, a supply of water sufficient to provide the service. The acceptance of any application for, and the furnishing of, such service shall be on the basis of pressures as they may exist in the locality, which pressures are not guaranteed by the County and may fluctuate significantly from time to time.

13.01.04

Due to the unusual requirements for safety, continuity and adequacy of private fire protection service, the use of water through private fire protection facilities must and shall be limited to the combating of fires only and shall not be used for general water supply.

13.01.05

A customer applying for private fire protection service shall present to the County a complete description of the requested service, giving the details of feeder lines and connections, hydrants, sprinklers, hose connections, etc., installed or to be installed in the customer's premises.

End of Chapter

CHAPTER 14

Razing or Moving Building

14.01 Authorization

- 14.01.01 No unauthorized person shall uncover, disconnect, alter, or disturb a public or private sanitary sewer, waterline, or appurtenance thereof without first obtaining permission from the Stark County Sanitary Engineering Department.

14.02 Requirements

- 14.02.01 Upon the demolition of a structure or the abandonment of an existing sanitary sewer line, the abandoned sewer line shall be sealed according to the specifications of the Stark County Sanitary Engineering Department. The owner of the property, or his agent, shall obtain a disconnect permit form and request that the Stark County Sanitary Engineering Department inspect and witness the disconnection and sealing. Disconnection must be made at the right-of-way line or as close to the local service sewer as possible as determined by the Stark County Sanitary Engineer's on site inspector.
- 14.02.02 All sanitary sewer lines shall be sealed according to the Stark County Metropolitan Sewer District's specifications under the direction of the Stark County Sanitary Engineer's on site inspector. Different pipe types will require different sealing techniques as presented by the inspector.
- 14.02.03 Sewer use billing will not be terminated until the disconnect permit has been issued and the disconnection witnessed by the Stark County Metropolitan Sewer District. The disconnect permit will not be issued until all current and past due sewer invoices for the property have been paid in full.

End of Chapter

CHAPTER 15

Disconnection, Connection Freeze, Reconnections

15.01 Disconnection-Sewer

- 15.01.01 All owners of buildings, or sites of former buildings connected to the Stark County Metropolitan Sewer System, which have not been issued a Razing Permit and where the sewer connection has not been sealed according to the Specifications of the Stark County Metropolitan Sewer District, shall be subject to the current sewer usage charge of the Stark County Metropolitan Sewer District until such sewer connection is properly sealed and confirmed by the Stark County Metropolitan Sewer District.
- 15.01.02 There shall be no temporary disconnections or exemptions from the sewer usage charges except in those cases in which a recognized court of law has prohibited occupancy of the building being served.
- 15.01.03 Where a disconnection is authorized, it shall be made per Chapter 14 of these Rules and Regulations. A disconnection permit shall be obtained from the Stark County Metropolitan Sewer District and will be issued only after all current and past due billing on the account are satisfied..
- 15.01.04 Disconnection shall be made at the Right of Way or edge of the easement line nearest the main sanitary sewer to which the service lateral is connected and shall be accomplished in a manner to assure that no surface or ground water can enter the system. (See Chapter 14 Section 14.02.02).
- 15.01.05 The disconnection shall be witnessed and approved by a Stark County Metropolitan Sewer District Inspector prior to backfilling the excavation.
- 15.01.06 The charge for the "Disconnect Permit" shall be as listed in Chapter 19.

15.02 Disconnection –Sewer as an Enforcement Action

- 15.02.01 As an alternative method of enforcing the provisions of Chapter 19, the Stark County Metropolitan Sewer District shall have the power to disconnect the user's sewer system from the public sewer at the service sewer connection. Upon disconnection, the District shall estimate the cost of disconnection from and reconnection to the system. The user shall then deposit this calculated cost estimation with the District before being reconnected to the system. The District shall refund any part of the deposit remaining after payment of all costs of disconnection and reconnection.

15.03 Shut-off-Water

- 15.03.01 When the County intends to interrupt water service to an area, as much advance notice (except in case of emergency) as is practicable under the circumstances shall be given to those affected by the shut-off, stating the probable duration of the service interruption.
- 15.03.02 The County may shut-off, without notice, all or any part of its service to any customer for any of the following reasons:

- 1) For the use of water for any purpose or upon any premises other than that stated in the associated water permit application.
- 2) To prevent the waste of, theft of, or to reasonably avoid the loss of water.
- 3) For tampering with any service line, meter, curb stop, curb box, seal, or other appurtenance under the control of or belonging to the County.
- 4) For continued vacancy of the premises.
- 5) For connecting the service line, or any pipe, directly or indirectly connected therewith, to any other source of supply or with any apparatus which may, in the opinion of the County, contaminate the County's water supply.
- 6) For denial of reasonable access to County personnel of the premises for the purpose of inspection, reading, repairing, or removing meters.
- 7) For 3 months of continuous delinquency or nonpayment of the water account
- 8) For any other violation of, or failure to comply with the regulations of the Stark County Metropolitan Sewer District.

15.03.03 Shut-off due to 3 months continuous delinquency

- 1) A customer approaching their third month of delinquent water payments is sent a letter from the Billing Department indicating their delinquent status as a potential for having their water service shut-off. The letter will be sent out to the service address and owner of property. No checks will be excepted after the letter is mailed and payment can only be made with credit card, cash, money order, or certified checks.
- 2) The day after bills are mailed, and three working days prior to the water being shut-off, a red door hanger is placed at the service address. (See Exhibit 1)
- 3) After three days and on the day of the shut off, but before the water is turned off, a blue card is hung on the door which has the information and instructions for getting service reinstated.
- 4) After payment, the water service will be reinstated within two working days

15.03.04 In any case in which two or more customers are supplied water through one service line the County is entitled under Section 15.03.02 to shut-off service to any or all of said customers until individual service lines and meters are installed for each customer.

15.04 Reconnection-Sewer

15.04.01 Existing building sewers may be used to connect new buildings only when they are inspected by and found compliant with these Rules and Regulations and the Specifications

of the Stark County Metropolitan Sewer District. The County shall not be held liable for any existing service sewer found compliant under these Rules and Regulations, which fails at a later date.

15.04.02 The charge for a reconnection permit shall be the same as the new permit fee for sewer connection.

15.05 Reconnection-Water

15.05.01 A service disconnected for non-payment of bills or for violation of, or failure to comply with, the regulations of the County, may be reconnected only after the customer:

- 1) Has paid all unpaid bills for water service owed to the County.
- 2) Has paid a reconnection or “turn-on fee” as set forth in the County's rate schedule.
- 3) Has corrected any conditions in violation of the regulations of the County.

15.05.02 It may be necessary for the Stark County Metropolitan Sewer District to gain entrance to a customer's home/building to repair a meter. Customers notified of such a need shall promptly make access to the meter during the County's regular business hours on any day except Saturday, Sunday and holidays. When access to the meter is not possible during regular business hours, a time and day can be scheduled and the County shall charge the customer for the actual labor cost of such meter service. If a customer denies access to their meter for a period exceeding three (3) months, the County may discontinue service to the customer upon giving a seven (7) day written notice of its intention to do so.

End of Chapter

Exhibit 1

The front side of card reads as follows:

**Stark County Metropolitan
Sewer District Water Division
Disconnection Notice**

ACCT. NO. _____

Name: _____

Address: _____

Date: _____

Water Service to this residence has been disconnected due to non-payment. See the reverse side for conditions to restore service.

Reverse side of card reads as follows:

Water service to this residence has been disconnected due to non-payment.

Water service will be restored within two working days (not including weekends and holidays) upon receipt of all past due amounts, plus a service charge. The service charge is \$30.00. These amounts must be paid at our offices at 1701 Mahoning Road NE, Canton, Ohio; Monday through Thursday between the hours of 8:00 A.M. and 4:25 P.M.

We regret this inconvenience; if you have any questions, please contact us at the phone numbers listed below.

Monday thru Friday: 8:00 to 4:25Phone: 330-451-2306

After Normal Business HoursPhone: 330-451-2320

STARK COUNTY METROPOLITAN SEWER DISTRICT

Water Division

Note: Bring this card with you when paying delinquent charges.

CHAPTER 16

Mobile Homes, Trailers, Parks

16.01 Requirements

Each Mobile Home, Trailer Home, etc., shall be considered as a single family residence or building in all Rules and Regulations of the Stark County Metropolitan Sewer District unless otherwise noted or considered by a said Rule and/or Regulation of the Stark County Metropolitan Sewer District.

16.02 Mobile Home Parks

16.02.01 Each Mobile Home Park designated as a long-term facility for mobile homes, trailer homes, etc., shall be required to obtain a permit for each pad or space designated for trailer or mobile home use before connecting to any sewer or appurtenance or waterline thereof of the Stark County Metropolitan Sewer District.

16.02.02 All connection charges required for any mobile or trailer home shall be paid at the time of issuance of the permit required for said connection.

16.03 Temporary Mobile Home Parks, Camps

Each Mobile Home Park, Camp, etc., designated as a short-term or temporary facility for mobile or trailer homes, campers, recreational vehicles, etc., shall be required to obtain the approval of the Stark County Sanitary Engineer before connecting to or discharging into any sewer or appurtenance or connecting to a waterline thereof of the Stark County Metropolitan Sewer District.

End of Chapter

CHAPTER 17

Annexation

17.01 Requirements

From time to time territory in unincorporated areas of the county which contain County Sewers and/or waterlines are annexed into municipal corporations. Such annexation does not convey ownership of County sewers or waterlines in the annexed area to the municipality. Formal and legal conveyance to the municipality of the County Facilities occurs only by specific resolution of the Stark County Board of Commissioners. Until such conveyance takes place, users of this sewer or water system shall remain County customers.

End of Chapter

CHAPTER 18

Drain Layer & Waterline Installer

18.01 Requirements

18.01.01 Any person, firm, or corporation who desires to engage in the work of construction and building public sanitary sewers, service sewers or special sanitary sewers in the Stark County Metropolitan Sewer District, must obtain a Drain Layers License from the Stark County Metropolitan Sewer District. Contractors installing water service lines and appurtenances must be registered with the Stark County Health Department.

No contractor shall be permitted to complete any sewer or water line work in the Stark County Metropolitan Sewer District until so registered.

18.01.02 Any person, firm, or corporation possessing either a Drain Layers License or registered as a plumber with the Stark County Health Department, shall obtain and submit to the Sanitary Engineer a bond in the amount required by the Stark County Commissioners to install sanitary service, building sewers and waterlines. The bond shall be released conditioned upon the faithful execution of the work undertaken as provided by these Rules and Regulations and the Specification of the Stark County Metropolitan Sewer District. The bond shall indemnify and save harmless the Stark County Commissioners and the Stark County Metropolitan Sewer District from all loss or damage occasioned by the performance of the work undertaken.

18.01.03 A minimum of forty eight (48) hours' notice must be given the Stark County Sanitary Engineering Inspection Department before initiating any construction work requiring inspection. If a forty eight (48) hour notice is not given to the Department, inspection may not be scheduled. All work must be left uncovered until the inspector has approved the work.

The Stark County Metropolitan Sewer District does NOT guarantee that inspections will be scheduled within 24-hours of notification.

18.01.04 Any work not ready for inspection at the scheduled time shall be rescheduled through the Department Office and the charges of mileage and labor associated with the inspector's mobilization to the job site will be charged to the drain layer or plumber.

18.01.05 Any work scheduled and started but not completed on the same day will be considered scheduled for completion on the following working day.

18.01.06 Any work scheduled and cancelled on the same day will be rescheduled at the convenience of the Stark County Metropolitan Sewer District.

18.01.07 Failure to comply with the above requirements may result in the revocation or suspension of the appropriate license. A licensed company that allows an unlicensed company to do work under its name will also be subject to license revocation or suspension.

18.01.08 All applicants for a drain layer's license shall take and pass an examination with a score of 70% or better. Any applicant that scores less than 100% on the examination is required to

personally review their examination and correct incorrect answers. In the event an applicant scores less than 70%, a re-examination shall be taken at a later date.

18.01.09 The drain layer or plumber's company name shall appear on the license.

18.01.10 A copy of the license shall be available on the job site at all times.

18.02 Service and Building Sewer Requirements

18.02.01 Bedding is required on all sewer pipe as specified in accordance with the most current Stark County Metropolitan Sewer District's PVC/Building Sewer Installation specifications.

18.02.02 A minimum of 4" of bedding is required below a sewer pipe.

18.02.03 Granular bedding shall extend to 1 ft. above the top of sewer pipe.

18.02.04 A minimum of 4 feet of cover is required over the pipe.

18.02.05 Gasketed PVC shall be used for service and building sewers in accordance with the most current Stark County Metropolitan Sewer District material specifications. Connection of the building sewer to the service sewer at the right-of-way may be made, in the case where dissimilar pipe materials are being joined, with stiffened adapter couplings utilizing stainless steel bands that meet the requirements of ASTM C564-70, F477-76, C425-77 or C443-85A, as applicable.

18.02.06 A building sewer may not be installed within 10 feet of a water well or water line. If 10 feet of clearance cannot be maintained, the Stark County Metropolitan Sewer District shall be consulted to assist with a resolution to the conflict.

18.02.07 The drain layer and the building/property owner shall be responsible for ensuring that all sanitary discharges, including floor and garage drains, are directed to the sewer. All interior plumbing is to be inspected by the District's Registered Sanitarian prior to connection.

18.03 Waterline installer

18.03.01 In order to qualify as a waterline installer, an applicant must be registered with the County Health Department as either a journeyman or master plumber.

18.03.02 All waterline service installation procedures and practices shall follow the latest Stark County Metropolitan Sewer District's Water Service Policies and Procedures manual.

End of Chapter

CHAPTER 19

Schedule of Charges

19.01 Schedule

Permit for Sewer or Water Connection	\$100.00
Guarantee of Sewer Permit Issuance	\$ 5.00
Drain Layer License (Annual)	\$30.00
Inspection (Hour) / Holidays, Saturdays and overtime (Hour)	\$50.00 / \$75.00
Disconnection Permit	\$30.00
Pipeline Testing Water Disposal	\$2.25/1,000 gal + \$135.00 Admin Fee
Tap Fee	--On file at the Stark County Metropolitan Sewer District
Assessment	--On file at the Stark County Metropolitan Sewer District
Monthly User Fee	--On file at the Stark County Metropolitan Sewer District
Copy of Rules and Regulations	\$ 5.00

19.02 Billing – Sewer

All users shall be billed on a monthly or bi-monthly basis as established by the Stark County Board of Commissioners.

19.02.01 Penalty

Penalties shall be added to any bill remaining unpaid ten (10) business days after rendered.

Said late bills shall be increased by ten percent (10%) and the amount of the bill as so increased shall constitute the gross bill. If the entire bill is paid within ten (10) business days after it is rendered, the net bill consisting of the charges without such increase shall constitute payment in full. If a portion of the bill is paid within the 10-day period, that portion which has not been paid within the 10-day period shall have a penalty added to that unpaid portion, said penalty being equal to ten percent (10%) of the unpaid portion, but in no case shall the penalty be less than \$0.25. If no portion of a bill is paid within the 10-day period, then the amount payable is that which constitutes the gross bill.

The last day business receipt of payment prior to penalty shall be designated on the bill and shall be not less than 10 business days after rendering. In order to avoid penalty, payment must be received by the last day designated for net payment as shown on the bill. The following guidelines shall apply for determining what constitutes payment

received on the last day designated for net payment: If payment is received in person at the Sewer Billing Department, the customer's stub is stamped with the date of receipt.

19.02.02 Effective Date for New Connection

That the effective date for a new County sewage user shall be the date of connection to the system as certified by the County's Sewer Inspector. The charge shall be for a full month's service if such connection occurs on or before the 15th of the month; if such connection occurs on or after the 16th of the month, there shall be no charge for the month.

19.02.03 Charge Continues Until Disconnected

As long as a structure is connected to the County sewer system, applicable sewer use charges apply whether occupied or vacant.

19.02.04 Charge a Lien upon Premises

That each sewer charge authorized and levied by Commissioners' Resolution is hereby made a lien upon the premises therewith and any bills not paid when due shall be deemed delinquent and together with all penalties, shall be certified by this Board to the County Auditor who shall place the same upon the real property tax list and duplicate against the property served by the connection. Such charges shall be a lien on such property from the date the same is placed upon the real property tax list and duplicate by the Auditor and shall be collected in the same manner as other taxes.

19.02.05 Charges for NSF Checks, Closed Accounts and Other Back Charges

Charges that the Stark County Metropolitan Sewer District incurs from NSF checks, closed accounts and other business transactions that involve a back charge to the Department will be transferred to the errant account for payment the next billing cycle. All fees of this type will be additive and subject to the delinquent process to the point of certification.

19.02.06 Duties of County Sanitary Engineer

That the County Sanitary Engineer is hereby charged with the responsibility for:

- 1) Administering and enforcing the Resolution of the Board of Stark County Commissioners concerning rates and charges.
- 2) Determining the classification of users, schedules, and the number of benefit units upon which rates and charges are based.
- 3) Determining changes that occur in premises or use which result in change of classification, schedule or rate.
- 4) Adjusting charges and/or penalties for just cause shown.

19.03 Water Billing

19.03.01 Monthly Meter Reading and Billing

All meters shall be read monthly and all users shall be billed monthly on the basis of the actual readings except that, if access to a user's meter is unobtainable for a timely reading during a particular month, the usage during that month shall be estimated by the Stark County Metropolitan Sewer District on the basis of the actual usage during the same calendar month in previous years or the actual usage during previous months. Upon the request of any party to the transfer of title of property to which service is provided or his agent, made at least fourteen (14) days prior to the transfer, the meter at that property shall be read and a final bill for all outstanding charges for water service shall be rendered within ten (10) business days following such request.

To encourage prompt payment of each monthly bill, a ten percent (10%) penalty shall be added to any bill unpaid ten (10) business days after rendering. All bills shall be increased by ten percent (10%) and the amount of the bill as so increased shall constitute the gross bill. If the bill is paid within ten (10) business days after it is rendered, the net bill consisting of the charges without such increase shall constitute payment in full. The last day for receipt of payment prior to the effectiveness of the penalty shall be designated on the bill and shall be not less than ten (10) business days after its rendering. Public agencies and political subdivisions shall, however, be exempt from any such penalty.

19.03.02 Effective Date for New Connection

The effective date for a new connection to the System shall be the date determined by the inspector designated by the Stark County Metropolitan Sewer District. If the effective date occurs on or before the 15th day of the month, the initial meter reading shall be taken for billing purposes at the end of the month in which the connection was made. If the effective date occurs after the 15th day of the month, the initial meter reading shall be taken at the end of the month following the month in which the connection was made.

19.03.03 Termination of Service

Accounts where monthly invoices remain unpaid longer than 90 days shall be turned off at the curb stop until the current account balance is paid. Such accounts will be charged a "turn off/turn on" charge as established by Commissioners' Resolution.

19.03.04 Charges a Lien upon Premises

All water charges authorized and imposed by Commissioners' Resolution and not paid when due shall be deemed delinquent and shall, together with all penalties thereon, be certified to the County Auditor for collection; provided that the unpaid charges shall have arisen pursuant to a service contract made directly with the owner of the property served by the connection for which the charges have been made; and provided further that, prior to any such certification to the County Auditor, any partial payment in the amount of \$10.00 or more shall be accepted. Upon the certification of the unpaid charges to him, the County Auditor shall place the certified amount on the real property tax list and duplicate against the property served by the connection. The amount certified shall be a lien on such property from the date placed on the list and duplicate and shall be collected in the same manner as other taxes, except that payment in such amount shall be accepted by the County Treasurer when separately tendered as payment for the full amount of the unpaid

charges and penalties thereon. The lien shall be released immediately upon payment of the certified amount.

19.03.05 Billing Disputes

Any user may request a meeting with the Sanitary Engineer or his designee to dispute the amount of a bill within seven (7) days after the bill is rendered, and the meeting shall be held within seven (7) days after such request. The Sanitary Engineer or his designee shall thereupon determine whether the amount of the disputed bill should be reduced, and if so, the amount of such reduction shall be credited, first against any outstanding bill of that user and, second, against the next bill rendered to that user. The Sanitary Engineer shall adjust charges and/or penalties for just cause shown.

End of Chapter

CHAPTER 20

Metered Service-Water

20.01 Meter Procedure

- 20.01.01 The County will install a water meter after the service line and plumbing has been made ready for such installation by the customer. The meter shall be operated and maintained by the County. Meters so installed shall remain the County's property and shall not be moved or tampered with in any manner.
- 20.01.02 Each service line must be separately metered and no meter may be used to serve more than one premises, except when special arrangements are made with the County for multiple units. Such special arrangement shall be entered into solely at the discretion of the County and shall provide for the metering of water service through one or more meters to two or more residential or commercial units, or combination thereof, per meter.
- 20.01.03 All meters placed in buildings shall be located in the basement, or if there is no basement, then on the first floor, as near as possible to the point of entrance of the service line. Meters shall be located in a clean, dry, secure area, not subject to freezing, in order to be easily accessible for installation, disconnection and reading.
- 20.01.04 Each meter shall be located at a point approved by the County so as to measure the supply of water delivered to the premises served. A stopcock or valve approved by the County shall be provided on the service line at the inlet side and the outlet side. A suitable backflow valve shall be provided between the meter and the stopcock or valve on the outlet side of the meter to prevent water backflow through the meter. A pressure relief valve must be inserted at some convenient point on the house piping to relieve the excess pressure due to heating water. A thermal expansion tank must be provided near the hot water tank, per plumbing code, with additional valves to allow the customer to turn off the water supply at the outlet side of the meter.
- 20.01.05 Curb stops and all other stop-locks and valves between the main and the meter are for the exclusive use of the County and shall not be used by the customer's plumber or other contractor for turning on or shutting off the water supply.
- 20.01.06 Water meters will be maintained by the County for ordinary wear and maintenance. Customers shall pay for all damage resulting from freezing, hot water backflow or negligence by the customer or customer's contractor. Damage costs may include removing, testing, repairing and reinstalling the meter.
- 20.01.07 The County reserves the rights to remove and test any meter at any time and substitute another meter in its place. In case of a disputed charge for service involving a question as to the accuracy of a meter, such meter will be removed for test upon the request of the customer and a charge shall be made as set forth in the user charge resolution. In the event that the meter so tested is found to have an error in registration greater than the limits set forth below, the fee advanced will be refunded, and the bill shall be corrected accordingly. The correction shall apply both for over and under registration.

1) All meters used for measuring quantity of water delivered to a customer shall be in good mechanical condition and shall be adequate in size and design for the type of service which they measure. Meters shall conform to AWWA Standard C700 (or latest revision) for displacement type meters and with AWWA Standard C701 (or latest revision) for turbine type meters.

2) The minimum, intermediate and maximum limits for positive displacement and turbine type water meters are as specified in AWWA Manual M6, Second Edition and are as follows:

<u>Type of Meter</u>	<u>Nominal Meter Size (in.)</u>	<u>Flow in G.P.M.</u>		
		<u>Minimum</u>	<u>Intermediate</u>	<u>Maximum</u>
Displacement	5/8	0.25	2	15
Displacement	3/4	0.50	3	25
Displacement	1	0.75	4	35
Displacement	1-1/2	1.50	8	50
Turbine	2	16	None	100
Turbine	3	24	None	150
Turbine	4	40	None	200
Turbine	6	80	None	500

20.01.08 At the discretion of the County, displacement meters shall be tested at each of the rates of flow stated above for the various size meters before installation. New meters must not register less than 95% of the water passed through at the minimum test flow. Meters shall not over-register or under-register more than 1-1/2% at the intermediate and maximum limit. A repaired meter shall not be placed in service if it registers less than 90% of the water passed through it at the minimum test flow or over-registers/under-registers more than 1-1/2% at the intermediate and maximum limit.

All meters tested in accordance with these rules for periodic or complaint testing shall be tested in the condition as found in the customer's service prior to any alteration or adjustment in order to determine the average meter error. Tests shall be made at the intermediate and maximum rates of flow and the meter error shall be the algebraic average of the errors of the two tests.

If the County finds that, as a result of the customer's willful act, a meter seal has been broken, any bypass inserted, or there is other evidence that the meter has been tampered with, water service to the building may be disconnected and restitution for the estimated water use will be billed to the violator.

Reconnection will not occur until the customer has paid the following:

- 1) A reconnection or turn-on fee as set forth in the user charge resolution.
- 2) The cost to restore the meter to proper working order.
- 3) The cost of the estimated quantity of water used based on the usage history for a comparable period of time. Unless the County can prove that tampering existed for greater than a three-month period, the County shall not backbill for a period exceeding three months or one quarter.

20.01.09 The County shall be permitted access to the meter with appropriate notification and scheduling. The notification procedure shall be as follows:

- 1) A letter shall be sent via standard mail informing the customer of the need to access the water meter. The customer shall contact the Stark County Metropolitan Sewer District to arrange County personnel to access to the meter.
- 2) If the customer does not respond within 2 weeks a second letter will be sent via standard and certified mail informing the customer of the need to access the water meter and that if a response is not received within 2 weeks the water service will be disconnected.

20.02 Meter Settings

20.02.01 A typical meter installation is shown in Figures 1 and 2. Location of all required valves and backflow prevention devices are shown. Provisions for installation of the water meter by Stark County Metropolitan Sewer District must be made by the owner/plumber as follows (in new construction the rough plumbing must be approved by the Stark County Health Department):

- 1) Meter to be positioned in a horizontal plane for optimum performance.
- 2) Meter to be reasonably accessible for service and inspection.
- 3) Meter to be reasonably protected against freezing, mechanical damage & tampering.
- 4) Meter shall not be an obstacle or hazard to the owner or interfere with public safety.
- 5) Any meter yoke not installed in accordance with all Stark County Metropolitan Sewer District requirements will be reinstalled at the sole expense of the owner/plumber.

20.03 Hydrant Meters

20.03.01 The Stark County Metropolitan Sewer District may issue hydrant meters to qualified contractors or civic organizations when alternate sources of water supply are not available. At the discretion of the Sanitary Engineer, meters are issued for a specified time period not to exceed three months. All hydrant meters issued shall be used only at the location specified on the application and may not be moved without permission from the Stark County Metropolitan Sewer District.

The limited supply of hydrant meters are issued on a first-come, first-serve basis. City, County, and State projects are given higher priority.

Hydrant meters may be requested by calling 330-451-2303. Meters may be picked up between 8:00 a.m. and 3:00 p.m. Monday through Friday. A meter deposit of \$250.00 will be collected for a ¾" meter and a deposit of \$2,500 will be collected for a 2.5" meter at the time of pickup. The customer must have a backflow prevention system validated and provide proof of validation to the Stark County Metropolitan Sewer District prior to the meter being activated.

Upon termination of use of the hydrant meter, the customer will return the meter to the Sanitary Engineer's Office and will be refunded or credited the deposit once the meter is read, tested, and examined for damage. The weekly charge for the use of the hydrant meter shall be the charge of the actual water used at the standard County rate or \$100.00 whichever is greater.

End of Chapter

FIGURE 1

DWG. NO. 38

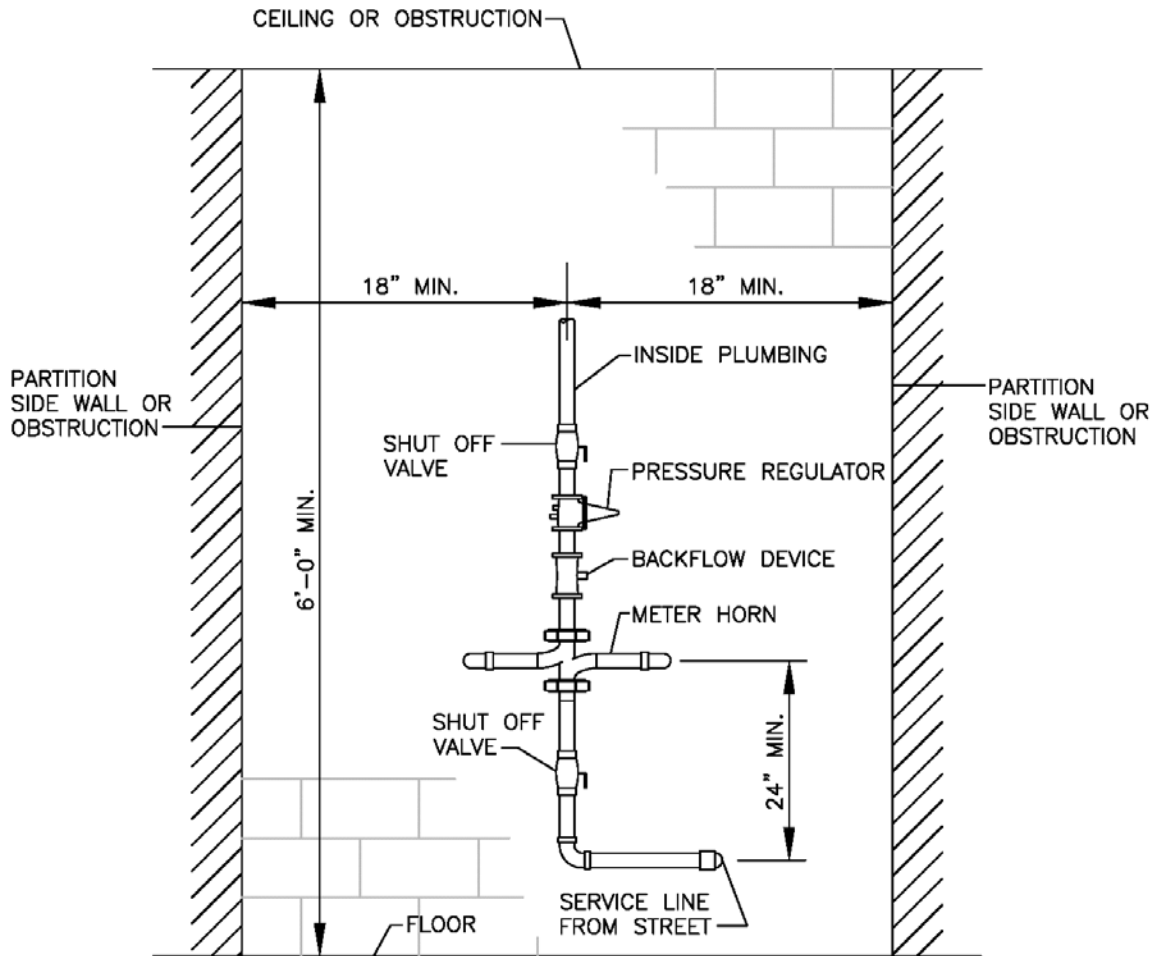

NOTES:

MINIMUM WALL CLEARANCE IS 30"

METER HORN TO BE INSTALLED WITHIN 2 FEET OF SERVICE LINE ENTRANCE FROM STREET.

C:\ENGIN\ENR\03231 Standard\SPRINGS & DETAILS\Standard Detail\DWG\Water\03231-039 IndoorWaterMeterDetail.dwg, 11/02/2014 9:22:11 AM

APRD 10/2014

REVISION	DATE	BY

STARK COUNTY SANITARY ENGINEERING DEPT	
DETAIL DWG. NO.	<u>38</u>
<u>VERTICAL STANDARD CLEARANCE FOR INDOOR WATER METER (RESIDENCE & SMALL BUSINESS)</u>	

NO SCALE

FIGURE 2

DWG. NO. 39

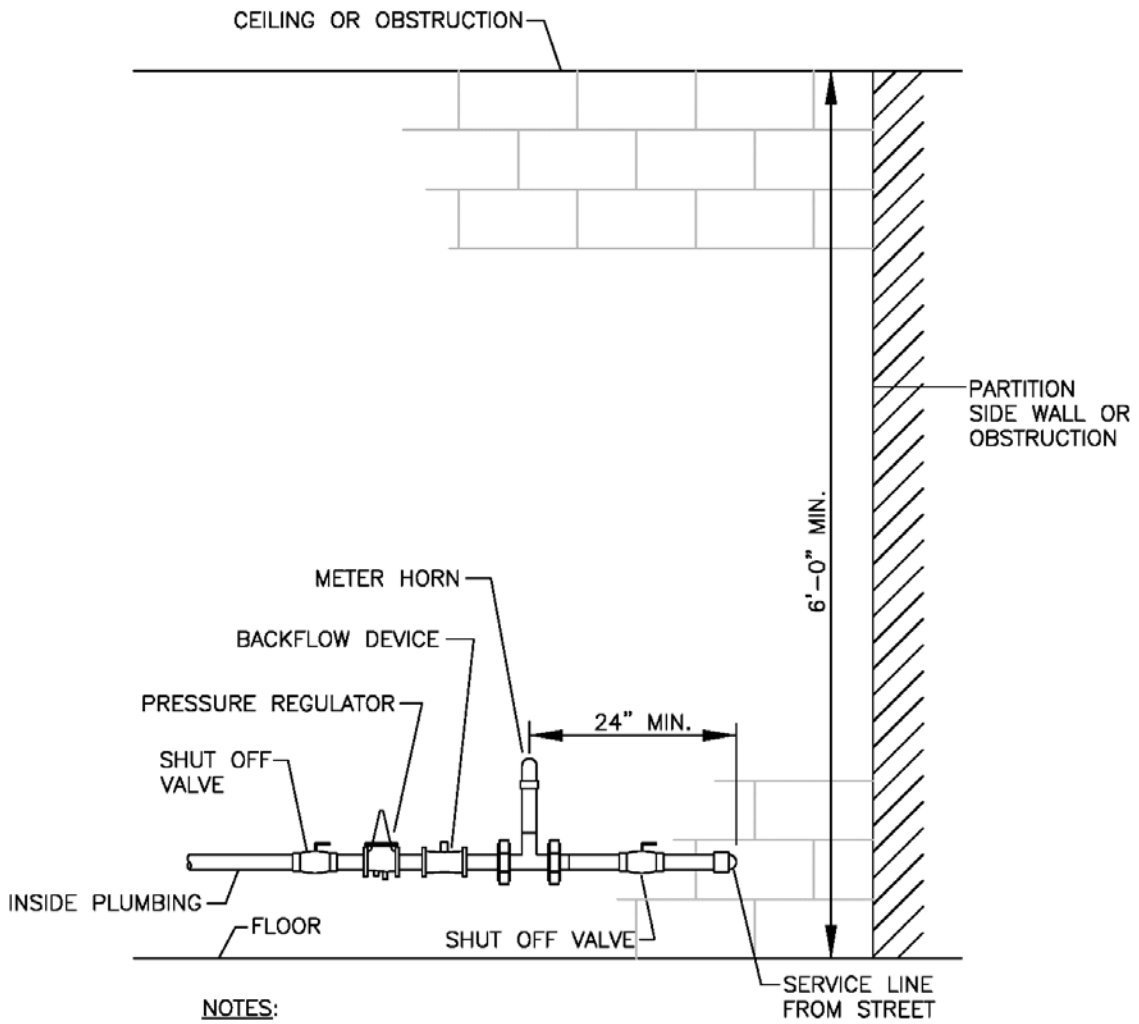

NOTES:

MINIMUM WALL CLEARANCE IS 30"

METER HORN TO BE INSTALLED WITHIN 2 FEET OF SERVICE LINE ENTRANCE FROM STREET.

APRD 10/2014

REVISION	DATE	BY

STARK COUNTY SANITARY ENGINEERING DEPT	
DETAIL DWG. NO.	39
HORIZONTAL STANDARD CLEARANCE FOR INDOOR WATER METER (RESIDENCE & SMALL BUSINESS)	

NO SCALE

C:\ENGINEERING\DESIGN\STANDARD\DETAILS\Standard Detail Drawings\Water\Water Meter\Water Meter Detail.dwg, 11/02/2014 9:28:28 AM

CHAPTER 21

Backflow Prevention and Cross Connection Control

21.01 Cross Connections

- 21.01.01 No person shall install or maintain a water service connection to any premises where actual or potential cross-connections to the County's water system may exist unless such actual or potential cross-connections are abated or controlled to the satisfaction of the County.
- 21.01.02 No person shall install or maintain any connection whereby water from an auxiliary water system may enter the County's water system. In no case shall an onsite water well be connected to the customer's water system which is connected directly to the County's water system. See Sections 21.03.02 and 21.04.01 for provisions regarding additional requirements for onsite wells.

21.02 Surveys, Investigations and Information

- 21.02.01 The County shall conduct periodic surveys and investigations of water use practices within a customer's premises to determine whether there are actual or potential cross-connections to the customer's water system through which contaminants or pollutants could backflow into the County's water system.
- 1) The County may use the information found on any water use survey questionnaire to conduct an on-site investigation if the information discovered on the survey indicates a potential cross-connection condition.
- 21.02.02 The County shall provide an on-going educational campaign to keep all residential water consumers informed of common backflow hazards created through residential water use. The educational material will provide a method by which to report suspected cross connections to the County.
- 21.02.03 The County shall have the right to enter premises served by the County's water system at all reasonable times for the purpose of making surveys and investigations of water use practices within the premises

21.03 Where Backflow and Cross Connection Protection Is Required

- 21.03.01 An approved backflow prevention device shall be installed on each service line to a customer's water system serving the premises. The minimum device required shall consist of a dual check valve meeting ASSE No. 1024 or current standard. A determination that a device affording a greater protection than that provided by dual check valve may be made based on the County's investigations. As part of the connection process, the customer is required to take out a plumbing permit issued by the Stark County Building Inspection Department. The plumbing inspector will determine the potential for cross connections and advise the Sanitary Engineering Department of its findings. He will also inspect any disconnections that may be required.
- 21.03.02 An approved backflow prevention device shall be installed on each service line to a customer's water system serving the premises where the following conditions exist:

- 1) Premises having an auxiliary water system; this definition includes onsite water well;
- 2) Premises on which any substance is handled in such a fashion as to create an actual or potential hazard to the County's water system. This shall include premises having source or systems containing process fluids or waters originating from a public water system which are not under the control of the County;
- 3) Premises having internal cross-connections that, in the judgment of the County, are not correctable, or intricate plumbing arrangements which make it impracticable to determine whether or not cross-connections exist;
- 4) Premises where, because of security requirements or other prohibitions or restrictions, it is impossible or impractical to make a complete cross-connection survey;
- 5) Premises having a repeated history of cross-connections being established or re-established.

21.03.03 An approved backflow prevention device shall be installed on each service line to a customer's water system serving, but not necessarily limited to, the following types of facilities;

- 1) Hospitals, mortuaries, clinics, nursing homes;
- 2) Laboratories;
- 3) Sewage treatment plants, sewage pumping stations, or storm water pumping stations;
- 4) Food or beverage processing plants;
- 5) Chemical plants;
- 6) Metal plating industries;
- 6) Petroleum processing or storage plants;
- 7) Car washes.

21.03.04 An approved backflow prevention device shall be installed at a point directly downstream of the water meter outlet.

21.04 Type of Protection Required

21.04.01 The type of protection required under Section 21.03 shall depend on the degree of hazard that exists as follows:

An approved air gap separation shall be installed where a public water system may be contaminated with substances that could cause a severe health hazard;

An approved air gap separation or an approved reduced pressure principle backflow prevention device shall be installed where a public water system may be contaminated with any substance that could cause a system or health hazard.

An approved air gap separation or an approved reduced pressure principle backflow prevention device or an approved double check valve assembly shall be installed where a public water system may be polluted with any substance that could cause a pollution hazard.

An approved reduced pressure principle backflow prevention device shall be installed if an onsite water well remains operational or intact (not abandoned).

21.05 Thermal Expansion Tanks

When a backflow prevention device, check valve, or pressure reducing device is installed in the cold water supply to a water heater, an expansion tank or other device designed in accordance with accepted engineering practices for thermal expansion control shall be installed.

Cost of the tank(s), installation, and any necessary repair or replacement is at the sole expense of the owner.

End of Chapter

CHAPTER 22

Fats, Oils, and Grease Control

22.01 Introduction

22.01.01 The purpose of the Fats, Oils, and Grease Fog (FOG) Control Regulations are:

- 1) To prevent the introduction of FOG into the Public Sewer that will interfere with its operation.
- 2) To prevent the introduction of FOG into the Public Sewer, the Publicly Owned Treatment Works, and, if inadequately treated, into receiving waters.
- 3) To prevent sanitary sewer overflow (SSO) that can contaminate the soil, local water bodies and any property that is exposed to sewerage.
- 4) To prevent an obstruction in the sanitary sewer causing a backup of sewage into homes and businesses.
- 5) To reduce maintenance and repair costs, which are borne by all the users of the sanitary sewer system.

22.02 Applicability

22.02.01 This regulation shall apply to all non-domestic users of the Public Sewer.

22.02.02 Grease interceptors shall not be required for residential users.

22.02.03 This regulation shall apply to both new and existing facilities generating fats, oils, or greases as a result of food manufacturing, processing, preparation, or food service. These facilities are referred to as "Food Service Establishments" in this regulation, and are required to install, use, and maintain appropriate grease interceptors as required in Section 22.03 of this regulation. These facilities include, but are not limited to, restaurants, food manufacturers, food processors, hospitals, hotels and motels, prisons, nursing homes, and any other facility preparing, serving, or otherwise making any foodstuff available for consumption.

22.02.04 FOG Generators are responsible for maintaining grease interceptors in continuous proper working condition, by removing the oil and grease buildup in the interceptor at sufficient intervals to insure compliance with Stark County Metropolitan Sewer District Rules and Regulations. Further, FOG generators are responsible for inspecting, repairing, replacing, or installing apparatus and equipment as necessary to ensure proper operations and function of grease interceptors and compliance with discharge limitations at all times.

22.03 Grease Interceptors Required

22.03.01 New Facilities. Food processing or food service facilities which are newly proposed or constructed, or existing facilities which will be expanded or renovated to include a food service facility, where such a facility did not previously exist, shall be required to design, install, operate and maintain a grease interceptor in accordance with these regulations. Grease interceptors shall be installed and inspected prior to use.

22.03.02 Existing Facilities. Existing facilities undergoing any of the following shall be required to design, install, operate and maintain a grease interceptor in accordance with these regulations, when the existing grease trap does not comply with these regulations.

- 1) Interior remodeling to accommodate expansion or operational modification.
- 2) Changes of ownership or occupancy.
- 3) Major changes in their menu; and
- 4) When an existing facility experiences difficulty achieving compliance with maintenance and/or wastewater discharge limitations.

22.04 Location and Sizing Requirements:

22.04.01 The location of grease traps shall be outside the building and provide easy access for cleaning and inspection. Sizing methods described herein are intended to assist in determining grease trap/interceptor sizes that will afford the County's sanitary sewer system a minimum degree of protection against grease and other obstructing materials. In approving a customer's plumbing or grease interceptor design, the County does not accept liability for the system's failure to treat wastewater adequately to achieve the effluent quality requirements stated in Chapter 3. It is the responsibility of the generator and/or contractors to insure the appropriate level of treatment necessary for compliance with wastewater regulations.

Minimum acceptable grease interceptor sizing shall be accomplished as follows:

- 1) Sizing according to formulas found in Section 22.04.02 below.
- 2) Where sizing formulas result in determination of a grease interceptor less than 750 gallons in capacity, this minimum size is required wherever possible. The maximum required grease interceptor size shall be 3,000 gallons.
- 3) In instances where it is physically impossible to install an outside grease trap, a letter must be submitted to the Stark County Health Department stating the reasons it cannot be installed and then a general review by the Health Department will follow to verify the validity of the claim.
- 4) In the circumstance of "single service kitchens" with no food preparation (heat/serve only), that use only disposable paper and plastic service utensils, and do not have a high temperature dishwasher; a hydro-mechanical grease trap may be used. Additionally, when an exterior grease interceptor is deemed physically impossible as stated in 22.04.01.3, a hydro-mechanical grease trap may be used. The trap must meet PDI-G 101 specifications. In these instances, the grease trap is to be readily accessible for cleaning and maintenance. (See section 22.05 below.) Grease trap will be sized as per 22.04.02.

22.04.02 Grease Interceptor sizing formulas:

It is the responsibility of the generator and his/her contractors to ensure that the wastewater discharged from their facility complies with the County's discharge limitations. For the

purpose of plan review, a general assessment of grease trap/interceptor design and size will be performed using the following formula: (Source: Appendix H of the Uniform Plumbing Code, Grease Interceptor Sizing Worksheet.)

$$\begin{matrix} \text{(# of meals/per peak hour)} & \times & \text{(waste flow RATE)} & \times & \text{(retention)} & \times & \text{(storage)} & = & \text{size} \\ \text{(1)} & & \text{(2)} & & \text{(3)} & & \text{(4)} & & \end{matrix}$$

Factors:

(1) # of meals served at peak operating hour (Seating Capacity)x(Peak Factor):

- a. Peak Factor for Fast Food Restaurant is.....1.33
- b. Peak Factor for all other food service types is...1.00

(2) Waste Flow Rate:

- a. with dishwasher..... 6 gallon flow
- b. without dishwasher..... 5 gallon flow
- c. single service kitchen..... 2 gallon flow
- d. food waste disposer.....1 gallon flow

(3) Retention times:

- a. commercial kitchen waste/dishwasher.....2.5 hours
- b. single service kitchen/single serving.....1.5 hours

(4) Storage factors:

- a. fully equipped commercial kitchen..... 8 hr. operation = 1
- b. fully equipped commercial kitchen 16 hr. operation = 2
- c. fully equipped commercial kitchen24 hr. operation = 3
- d. single service kitchen.....= 1.5

22.04.03 Example:

A 75-seat restaurant is open from 4:00 pm. until 12:00 am.
It has a dishwasher and a fully equipped commercial kitchen on a normal street.

(Number of meals)x(waste flow)x(retention)x(storage)= size requirement
(75)(1)] x (6 gallons) x (2.5 hours) x (1) = 1125 gals.

22.04.04 Hydro-mechanical Grease Trap Sizing

- 1) Determine the volume of all fixtures being drained (cubic inches).
- 2) Convert cubic inches into gallons.
- 3) Determine actual drainage load (75% of total content).
- 4) Determine flow rate for 2-minute drainage period.
- 5) Flow rate = actual drainage load :- drainage period.

TABLE 22.04.01	
Capacity of Grease Traps	
Total Flow Through Rating (GPM)	Grease Retention Capacity (Pounds)
4	8
6	12
7	14
9	18
10	20
12	24
14	28
15	30
18	36
20	40
25	50
35	70
50	100
- Proper sizing to be approved by Stark County Health Department.	

22.05 Construction/Installation:

22.05.01 All permitting, construction, and inspection activities must be completed in accordance with the Ohio Plumbing Code. Additionally, the following specifications must be incorporated into grease interceptor design.

- 1) Commercial dishwashers must be properly designed, located, installed, and operated to prevent the introduction of detergents and/or high water temperatures capable of melting grease or causing grease to pass through the interceptor. Grease interceptors are to be installed at a minimum distance of 10 ft. from sinks and dishwashers to allow for adequate cooling of the wastewater. Water temperatures must be less than 140 degrees prior to entering grease interceptor. This includes intermittent discharges from sink and equipment resulting from water change outs or end of shift cleaning.
- 2) All grease bearing waste streams should be routed through an appropriate grease interceptor, including, but not limited to: three-compartment sinks, pot/pan sinks, soup kettles, and dishwashers. Mop sinks and floor drains may be routed to the interceptor if grease waste is expected. Drains that receive "clear waste" only, such as from ice machines, condensate from coils and drink station may be plumbed to the sanitary system without passing through the grease interceptor
- 3) All exterior grease interceptors will be equipped with a minimum of one twenty (20) inch diameter access hole, and additional access holes at the inlet and outlet sides

of the tank for ease of cleaning. All interceptors shall be vented. Concrete interceptors must meet the latest version of ASTM C1613-10, Standard Specification for Precast Concrete Grease Interceptor Tanks. High Density Polyethylene (HDPE) Interceptors must meet the latest version of ASTM F2649 (latest revision) Standard Specification for Corrugated High Density Polyethylene (HDPE) Grease Interceptor Tanks. Interceptors constructed of other materials shall meet the applicable ASTM standard. The pipe exiting the grease interceptor shall be installed six (6) to twelve (12) inches from the bottom of the tank, rather than near the top of the tank, to eliminate the risk of tee/baffle removal or breakage, which would render the interceptor ineffective. The pipe shall be installed to maintain the correct water level within the tank and be equipped with clean-outs to allow for line maintenance in either direction of flow. (See appendix A.)

22.06 Cleaning and Maintenance

22.06.01 It is the responsibility of the Generator (customer) to insure compliance with Stark County Metropolitan Sewer District discharge limitations. Grease interceptors must be operated and maintained in accordance with the manufacturer's recommendations and in accordance with these regulations, unless specified in writing and approved by the Sanitary Engineer.

- 1) Grease interceptors and sanitary lift stations shall be maintained in an efficient operating condition at all times.
- 2) Each grease interceptor or sanitary lift station wet well when cleaned shall be fully evacuated by removing all solids, wastewater and grease. Grease shall be removed from the interceptor walls, the inlet pipe and the outlet pipe by pressure washing, physical scraping or other acceptable means.
- 3) No interceptor or sanitary lift station shall create a nuisance during operation or cleaning.
- 4) Self-Cleaning: Hydro-mechanical Grease interceptors only.
 - a) Grease interceptor self-cleaning operators may remove grease from their own grease hydro-mechanical grease interceptors. The following conditions shall apply:
 - aa) The grease interceptor is no more than 100 GPM size.
 - ab) Proper on-site material disposal methods are implemented (e.g. absorb liquid into solid form and dispose into trash).
 - ac) The disposal methods do not create a nuisance and are done in accordance with law.
 - ad) Grease waste is placed in a leak proof, sealable container(s) located on the premises and in an area for the transporter to pump-out; and
 - ae) Detailed records on these activities are maintained.

- b) Grease interceptor self-cleaning operators must maintain a self-cleaning plan that meets cleaning schedule outlined in this regulation. The plan shall include the following information:
 - ba) Business name and street address;
 - bb) Grease interceptor operator name, title, and phone number;
 - bc) Description of maintenance frequency, method of disposal, method of cleaning, and size (in gallons) of the grease interceptor; and
- c) A maintenance log (appendix B) shall be kept by self-cleaning operators that indicates, at a minimum, the following information:
 - ca) Date the grease trap/interceptor was serviced;
 - cb) Name of the person or company servicing the grease trap/interceptor;
 - cc) Waste disposal method used;
 - cd) Gallons of grease removed and disposed of
 - ce) Waste oil added to grease interceptor waste and
 - cf) Signature of the operator after each cleaning that certifies that all grease was removed, disposed of properly, grease trap/interceptor was thoroughly cleaned, and that all parts were replaced and in operable condition.
- d) Violations incurred by grease interceptors' self-cleaners will be subject to enforcement action and may be required to contract with a grease removal service.

22.07 Cleaning Schedules

- 22.07.01 Grease interceptors shall be cleaned as often as necessary to ensure that sediment and floating materials do not accumulate to impair the efficiency of the grease interceptor; to ensure the discharge is in compliance with local discharge limits; and to ensure no visible grease is observed in discharge.
- 22.07.02 Grease interceptors shall be completely evacuated a minimum of every sixty (60) days or more frequently when:
 - 1) Twenty-five (25) percent or more of the wetted height of the grease trap or grease interceptor, as measured from the bottom of the device to the invert of the outlet pipe, contains floating materials, sediment, oils or greases; or

- 2) The discharge exceeds BOD, COD, TSS, FOG, pH, or other pollutant levels established by the Sanitary Engineer; or
- 3) If there is a history of non-compliance.

22.07.03 Any person who owns or operates a grease interceptor may submit to the Sanitary Engineer a request in writing for an exception to the sixty (60) day cleaning frequency of their grease interceptor. The Sanitary Engineer may grant an extension for required cleaning frequency on a case-by-case basis when:

- 1) The grease interceptor owner/operator has demonstrated the specific interceptor will produce an effluent, based on defensible analytical results, in consistent compliance with established local discharge limits such as BOD, TSS, FOG, or other parameters as determined by the Sanitary Engineer, or
- 2) Less than twenty-five (25) percent of the wetted height of the grease interceptor, as measured from the bottom of the device to the invert of the outlet pipe, contains floating materials, sediment, oils or greases.
- 3) In no case shall a grease interceptor be fully evacuated, cleaned, and inspected at an interval greater than once every one-hundred twenty (120) days.

22.08 Manifest Requirements

22.08.01 Each pump-out of a grease interceptor must be accompanied by the manifest provided in Appendix C for record keeping purposes.

22.08.02 Persons who generate, collect and transport grease waste shall maintain a record of each individual collection and deposit. Such records shall be in the form of a manifest. The manifest shall include:

- 1) Name, address, telephone of transporter;
- 2) Name, signature, address, and phone number of the person who generated the waste and the date collected.
- 3) Type and amount(s) of waste collected or transported.
- 4) Name and signature(s) of responsible person(s) collecting, transporting, and depositing the waste.
- 5) Date and place where the waste was deposited.
- 6) Identification (permit or site registration number, location, and operator) of the facility where the waste was deposited.
- 7) Name and signature of facility on-site representative acknowledging receipt of the waste and the amount of waste received.
- 8) The volume of the grease waste received and

- 9) A consecutive numerical tracking number to assist transporters, waste generators, and regulating authorities in tracking the volume of grease transported.

22.08.03 Manifests shall be divided into four parts and records shall be maintained as follows:

- 1) One part of the manifest shall have the generator and transporter information completed and given to the generator at the time of waste pickup.
- 2) The remaining four parts of the manifest shall have all required information completely filled out and signed by the appropriate party before distribution of the manifest.
- 3) One part of the manifest shall go to the receiving facility.
- 4) One part shall go to the transporter, who shall retain a copy of all manifests showing the collection and disposition of waste.
- 5) One copy of the manifest shall be returned by the transporter to the person who generated the wastes within 15 days after the waste is received at the disposal or processing facility.
- 6) Copies of manifests returned to the waste generator shall be retained for five years and be readily available for review by the Sanitary Engineer.

22.08.04 All grease interceptor waste shall be properly disposed of at a facility in accordance with federal, state, or local regulation.

22.09 Compliance Testing:

22.09.01 All testing designed to satisfy the criteria set forth in these regulations shall be scientifically sound and statistically valid. All tests to determine oil and grease, TSS, BOD, COD, pH, and other pollutant levels shall use appropriate tests that have been approved by the Environmental Protection Agency which are defined in Title 40, Code of Federal Regulations, Part 136. Testing shall be open to inspection by the Sanitary Engineer, and shall meet the Sanitary Engineer's approval.

22.10 Best Management Practices and Employee Training

22.10.01 BMP's. All Food Service Establishments shall implement the following Best Management Practices (BMPs) to minimize the discharge of FOG to the sewer system.

- 1) "Dry wipe" pots, pans, dishware and work areas before washing to remove grease.
- 2) Properly dispose of food waste and solids in enclosed plastic bags prior to disposal in trash bins or containers to prevent leaking and odors.
- 3) Use of absorption products to clean under fryer baskets and other locations where grease may be spilled or dripped.
- 4) Properly dispose of grease or oils from cooking equipment into a grease receptacle such as a barrel or drum without spilling.

- 5) Kitchen exhaust filters cleaned as frequently as necessary to be maintained in good operating condition. The wastewater generated from cleaning the exhaust filter must be disposed properly through a grease interceptor or grease trap.

22.10.02 Kitchen signage. Best management and waste minimization practices shall be posted conspicuously in the food preparation and dishwashing areas at all times.

22.10.03 Training. The ownership / management shall train all employees of a food processing or food service facility on BMP's at least annually. Records of training sessions and any accompanying educational materials shall be retained by the waste generator for five years and be readily available for review by the Sanitary Engineer.

22.11 Prohibited Practices

22.11.01 No person shall introduce, or cause, permit, or allow the introduction of any surfactant, solvent or emulsifier into a grease interceptor. Surfactants, solvents, and emulsifiers are materials that allow the grease to pass from the grease interceptor into the collection system, and include but are not limited to enzymes, soap, diesel, kerosene, terpene, gasoline and other solvents. Additionally, hazardous wastes, such as acids, strong cleaners, pesticides, herbicides, or paint shall not be introduced into a grease interceptor.

22.11.02 No user may intentionally or unintentionally allow the direct or indirect discharge of any fats, oils, or greases of animal or vegetable origin into the Public Sewer in such amounts as to cause interference with the collection and treatment system, or as to cause pollutants to pass through the treatment works into the environment.

22.12 Compliance Monitoring

22.12.01 Right of Entry. The Sanitary Engineer or his authorized agents shall have the right to enter the premises of any user or potential user to determine whether the user is complying with all requirements of this chapter and any wastewater discharge permit or order issued hereunder. Users shall allow the Sanitary Engineer ready access to all parts of the premises for the purposes of inspection, sampling, records examination and copying, and the performance of any additional duties.

- 1) Where a user has security measures in force, which require proper identification and clearance before entry into its premises, the user shall make necessary arrangements with its security guards so that, upon presentation of suitable identification, the Sanitary Engineer will be permitted to enter without delay for the purposes of performing specific responsibilities.
- 2) The Sanitary Engineer shall have the right to set up on the user's property, or require installation of devices as are necessary to conduct sampling and/or metering of the user's operations. The Sanitary Engineer may also require the user to install monitoring equipment as necessary, such as FOG sensing and alarm devices complying with PDI G102. The installation of all such devices shall be at the user's expense. The facility's monitoring equipment shall be maintained at all times in a safe and proper operating condition by the user at its own expense.

- 3) Any temporary or permanent obstruction to safe and easy access to the facility to be inspected and/or sampled shall be promptly removed by the user at the written or verbal request of the Sanitary Engineer and shall not be replaced. The costs of clearing such access shall be borne by the user.
- 4) Unreasonable delays in allowing the Sanitary Engineer access to the user's premises shall be a violation of this regulation.

22.12.02 Search Warrants. If the Sanitary Engineer or his authorized agent has been refused access to a building, structure, or property, or any part thereof, and is able to demonstrate probable cause to believe that there may be a violation of this chapter, then the Sanitary Engineer may seek issuance of a search warrant.

22.13 Enforcement

22.13.01 The Board of Commissioners finds that specific enforcement provisions must be adopted to govern discharges to the County's Public Sewer system by Food Service Establishments to ensure that the County's sewer facilities are protected and are able to operate with the highest degree of efficiency, and to protect the public health and environment.

22.13.02 The Sanitary Engineer or his authorized agent will determine noncompliance with the provisions of this FOG Control Regulation through visual inspections, records review, sampling, and/or monitoring of Food Service Establishments.

- 1) If, through visual inspection, the Food Service Establishment is found to be out of compliance or cannot provide the documentation requested by the Sanitary Engineer or his authorized agent, the establishment will be given 30 days to become complaint or to provide the requested documentation before it will be considered a violation.

22.13.03 When a Food Service Establishment is found to be in noncompliance with one or more of the provisions of this regulation, a written Notice of Violation (NOV) will be issued to the Food Service Establishment with a specified time frame to come into compliance. If the Food Service Establishment fails to properly address the causes and/or sources of the noncompliance, then the Sanitary Engineer may pursue additional enforcement options, including but not limited to:

- 1) Assess noncompliance fees to the Food Service Establishment. A Food Service Establishment determined to be in noncompliance with the provisions specified in this regulation shall pay a noncompliance fee. The purpose of the noncompliance fee is to compensate the County for costs of additional inspection and follow-up, clean up, sampling, monitoring, laboratory analysis, and administrative processing incurred as a result of the noncompliance.
- 2) Compliance Schedule. The Sanitary Engineer may enter into a Compliance Schedule with a Food Service Establishment. A Compliance Schedule may contain terms and conditions including but not limited to requirements for installation of a grease control device and devices to facilitate sampling, immediate and regular pumping and maintenance of grease control device, submittal of drawings or reports, submittal of waste hauling records, implementation of best management and waste minimization practices, payment of fees, or other provisions to ensure

compliance with this regulation. The Sanitary Engineer shall not enter into a Compliance Schedule until such time as all amounts owed by the Food Service Establishment to the County, including user fees, noncompliance sampling fees, and/or other amounts due are paid in full, or an agreement for deferred payment secured by collateral or a third party, is approved by the Sanitary Engineer.

- 3) Injunctive Relief. When the Sanitary Engineer finds that a user has violated or continues to violate any provision of this regulation, or order issued hereunder, or any other pretreatment standard or requirement, the Sanitary Engineer may petition the Court of Common Pleas for the issuance of a temporary or permanent injunction, as appropriate, which restrains or compels the user to comply with the performance standards stated in this regulation, or order imposed under this regulation. The Sanitary Engineer may also seek such other action as is appropriate for legal and/or equitable relief, including a requirement for the user to conduct environmental remediation. A petition for injunctive relief shall not be a bar against or a prerequisite for taking any other action against a user.
- 4) Terminate sewer service. After other means have failed to gain compliance, the Sanitary Engineer may terminate the user's sewer service. All costs for physical termination shall be paid by the owner or operator of the Food Service Establishment or Designee, as well as costs for reinstating service.

End of Chapter

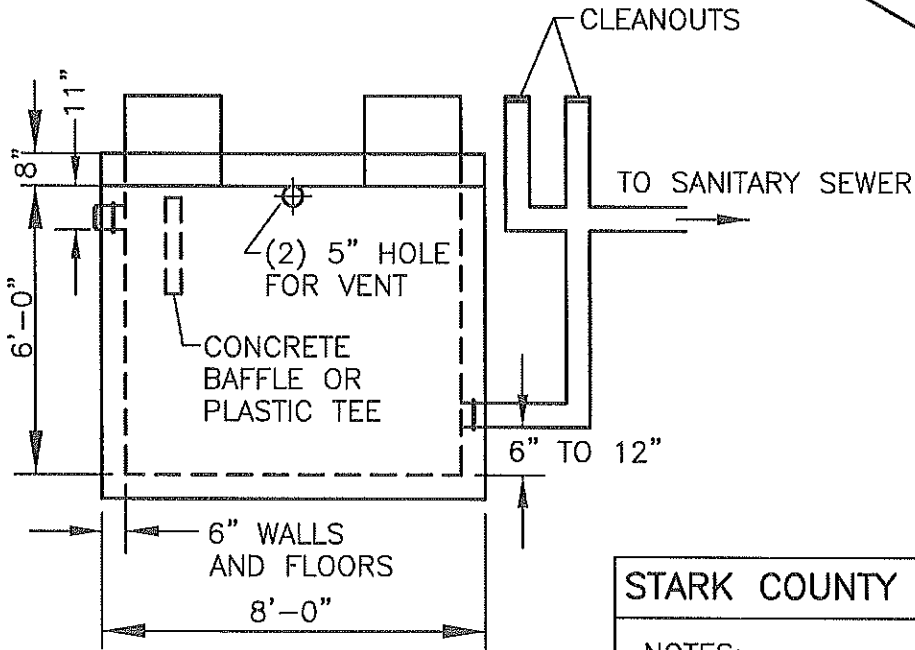
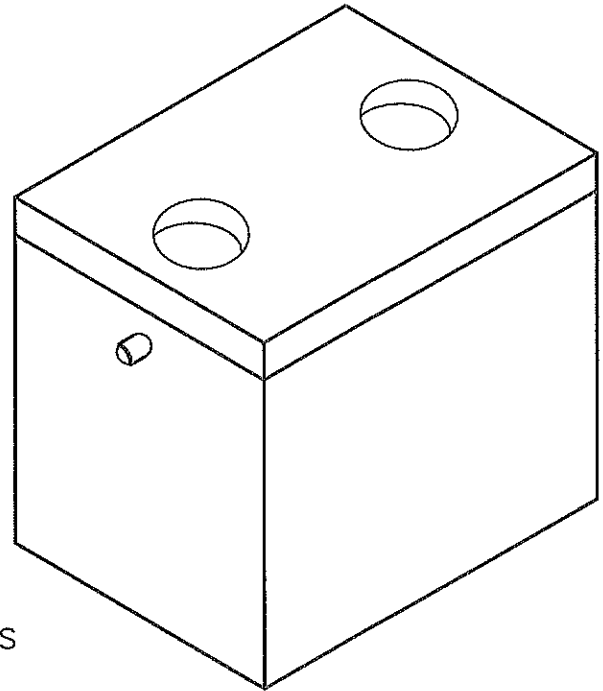
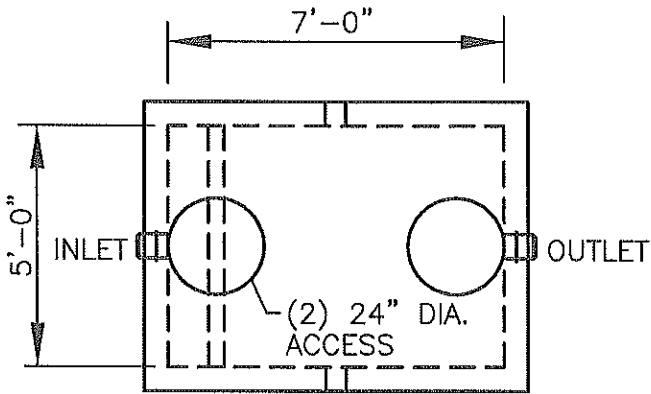

STARK COUNTY SANITARY ENGINEERING

NOTES:

GREASE INTERCEPTOR TO BE CONSTRUCTED IN ACCORDANCE WITH ASTM C1613-10.

BOTTOM OUTLET REQUIRED AS SHOWN TO PREVENT REMOVAL OF AN INTERNAL OUTLET TEE.

CLEANOUTS MUST BE INSTALLED TO FACILITATE BLOCKAGE REMOVAL IN EITHER DIRECTION.

TYPICAL GREASE INTERCEPTOR

GREASE TRAP CLEANING AND MAINTENANCE LOG

FACILITY NAME: _____ CONTACT NAME _____

FACILITY ADDRESS: _____ PHONE _____

ACCT. NO: _____ GREASE REMOVAL DEVICE SIZE: _____

CLEANING COMPANY: _____ PHONE: _____ ADDRESS: _____

(If Applicable)

	DATE	TIME	EMPLOYEE OR COMPANY	GALLONS REMOVED	METHOD OF DISPOSAL	COMMENTS/NOTED DEFECTS	WITNESS (Initials)
1							
2							
3							
4							
5							
6							
7							
8							
9							
10							
11							
12							
13							
14							
15							
16							
17							
18							
19							
20							

Fats, Oils & Grease (FOG) Waste Disposal Tracking Form

WASTE HAULER INFORMATION:
 NAME: _____ PHONE NO: _____
 ADDRESS: _____
 VEHICLE TAG NO: _____ TANK CAPACITY: _____ GALLONS

CUSTOMER INFORMATION:
 BUSINESS/COMPANY: _____
 PHYSICAL ADDRESS: _____
 TELEPHONE NO: _____
 TYPE OF DEVICE AT LOCATION: _____

INTERCEPTOR CONDITION:
 BAFFLE UNOBSTRUCTED & INTACT { } YES { } NEEDS REPAIR _____
 COVER ACCESSIBLE, IN GOOD CONDITION & SECURE { } YES { } NEEDS REPAIR _____
 OUTLET & INLET PIPES INTACT { } YES { } NEEDS REPAIR _____
 WALLS & BOTTOM IN GOOD CONDITION { } YES { } NEEDS REPAIR _____

ESTIMATED WASTE THICKNESS & VOLUME REMOVED FROM INTERCEPTOR, TRAP & OWS DEVICE:
 OIL/GREASE: _____ INCHES BOTTOM SOLIDS: _____ INCHES
 TOTAL DEVICE DEPTH: _____ INCHES VOLUME PUMPED: _____ GALLONS

CERTIFICATION:
 I certify that by checking this box and signing below all information listed above is true and accurate.
 I further certify the device listed above was thoroughly pumped and cleaned and no removed waste was system pumped back into the device or into the collection system.

Customer Printed Name: _____ Date: _____
 Customer Signature: _____
 Driver Printed Name: _____ Date: _____
 Driver Signature: _____

DISCHARGE APPROVAL:
 On the dates and times stated below, the wastes listed on this tracking form were approved for discharge, and were disposed by the hauler at the following and permitted disposal/treatment facility:
 Facility Name: _____
 Waste was received on this date: _____ Time: _____ Invoice/Ticket No: _____
 Operator Signature: _____ Printed Name: _____

CHAPTER 23

Oil/Water Separation

23.01 Introduction

23.01.01 Information contained within this document is based on standard industry practices and guidance found in both the 1997 International Plumbing Code (IPC) Commentary, the Uniform Plumbing Code (UPC) and the Ohio Administrative Code (4101:3-10-01). Location of Oil/Water Separators shall be outside the building and provide easy access for cleaning and inspection.

23.02 Applicability:

23.02.01 These requirements are applicable to all establishments servicing any type of equipment where petroleum-based oils, greases and fuels may be used or dispensed. This includes, but is not limited to, automobile/truck service or washing facilities, body repair shops, industrial facilities where oily or flammable liquid wastes are produced, non-alarmed elevator pits and any establishment that generates greater than 200 mg/L of total suspended solids in the waste stream, which is destined for a public sanitary collection system, including those establishments that are undergoing:

- 1) New construction
- 2) Interior remodeling to accommodate expansion or operational modifications
- 3) Changes of ownership/occupancy
- 4) Any facility which may be experiencing difficulty achieving compliance with maintenance and/or wastewater discharge limitations

23.03 Sizing Requirements:

23.03.01 Sizing methods described herein are intended to assist in determining oil/water separator sizes affording the Stark County Metropolitan Sewer District sanitary sewer system a minimum degree of protection against oils, fuels, grit and other obstructing materials. In approving a customer's plumbing or oil/water separator design, the County does not accept liability for the failure of a system to adequately treat wastewater to achieve the required effluent quality. It is the responsibility of the generator and/or contractors to insure the appropriate level of treatment necessary for compliance with wastewater regulations. Minimum acceptable oil/water separator sizing shall be accomplished as follows:

- 1) Where sizing formulas result in determination of an oil/water separator less than 500 gallons in capacity, this minimum size is required.
- 2) In instances where it is physically impossible to install an outside oil/water separator, a letter must be submitted to the Stark County General Health District stating the reasons it cannot be installed and then a general review by the Health Department will follow.

- 3) Oil/water separator sizing formulas: It is the responsibility of the generator and his/her contractors to ensure that the wastewater discharge from their facility complies with the Stark County Metropolitan Sewer District's discharge limitations. For the purpose of plan review, a general assessment of oil/water separator design and size will be performed using the following formulas. These formulas have been demonstrated as industry standards capable of achieving the Stark County Metropolitan Sewer District's discharge criteria when systems are maintained in proper condition.
 - a) The oil/water separator must have a minimum of 6 ft³ for the first 100 ft² of floor space to be drained.
 - b) For each additional 100 ft² of drained floor space, the oil/water separator size shall be increased by 1 ft³.
 - c) The minimum size for the oil/water separator is 500 gallons.

23.04 Construction/Installation

23.04.01 All permitting, construction and inspection activities must be completed in accordance with the Stark County Plumbing code. Additionally, the following specifications must be incorporated into oil water separator design:

- 1) The oil/water separator shall be constructed with a minimum of one baffle.
- 2) The oil/water separator shall have a depth of not less than 2 feet below the invert of the discharge drain. The outlet opening of the separator shall not have less than an 18-inch water seal.
- 3) All concrete oil/water separators will be equipped with a minimum of one 20-inch diameter access hole, and additional access holes at the inlet and outlet sides of the tank to ease cleaning. All oil/water separators must be sealed using watertight access ways and be vented with at least 2-inch diameter vent line. The vent line must be directed outdoors and must be at least 6-inches higher than the spill line of the lowest floor drain.

23.05 Customer (Generator) Responsibilities:

23.05.01 It is the responsibility of the customer (waste generator) to insure compliance with the Stark County Metropolitan Sewer District discharge limitations.

23.05.02 Hazardous wastes, such as acids, strong cleaners, pesticides, herbicides, paint, solvents, or gasoline shall not be directly disposed of where they would go through the oil/water separator or grit trap. Care must be taken in system design to insure proper venting, sealing and the reduction in wastewater velocity to maximize oil/fuels and oily type waste capture in the tank.

23.05.03 Generators are responsible for maintaining oil/water separators in continuous proper working condition, by removing the oils/fuels and grit buildup in the separator at sufficient intervals to insure compliance with Stark County Metropolitan Sewer District Rules and regulations Chapter 3, Section 3.02.13. Further, generators are responsible for inspecting, repairing, replacing, or installing apparatus and equipment as necessary to ensure proper operations and function of oil/water separators and compliance with discharge limitations at all times.

- 23.05.04 The Stark County Metropolitan Sewer District and the Stark County General Health Department District requires oil/water separator maintenance records be maintained on site for review and inspection by each agency for the life of the system.
- 23.05.05 The use of enzymes, solvents, and emulsifiers are prohibited, as they will only change the form of oils allowing them to be carried out of the separator with the wastewater and deposited downstream in the collection system.

End of Chapter

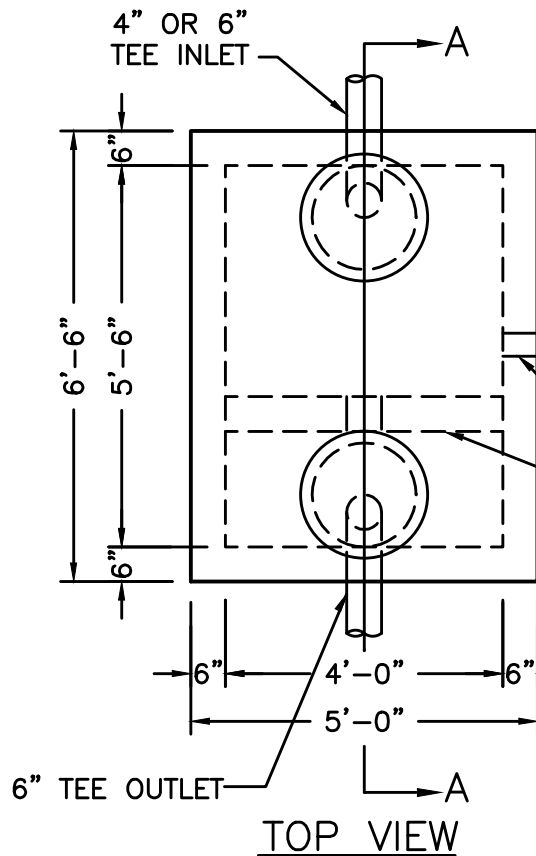

TOP VIEW

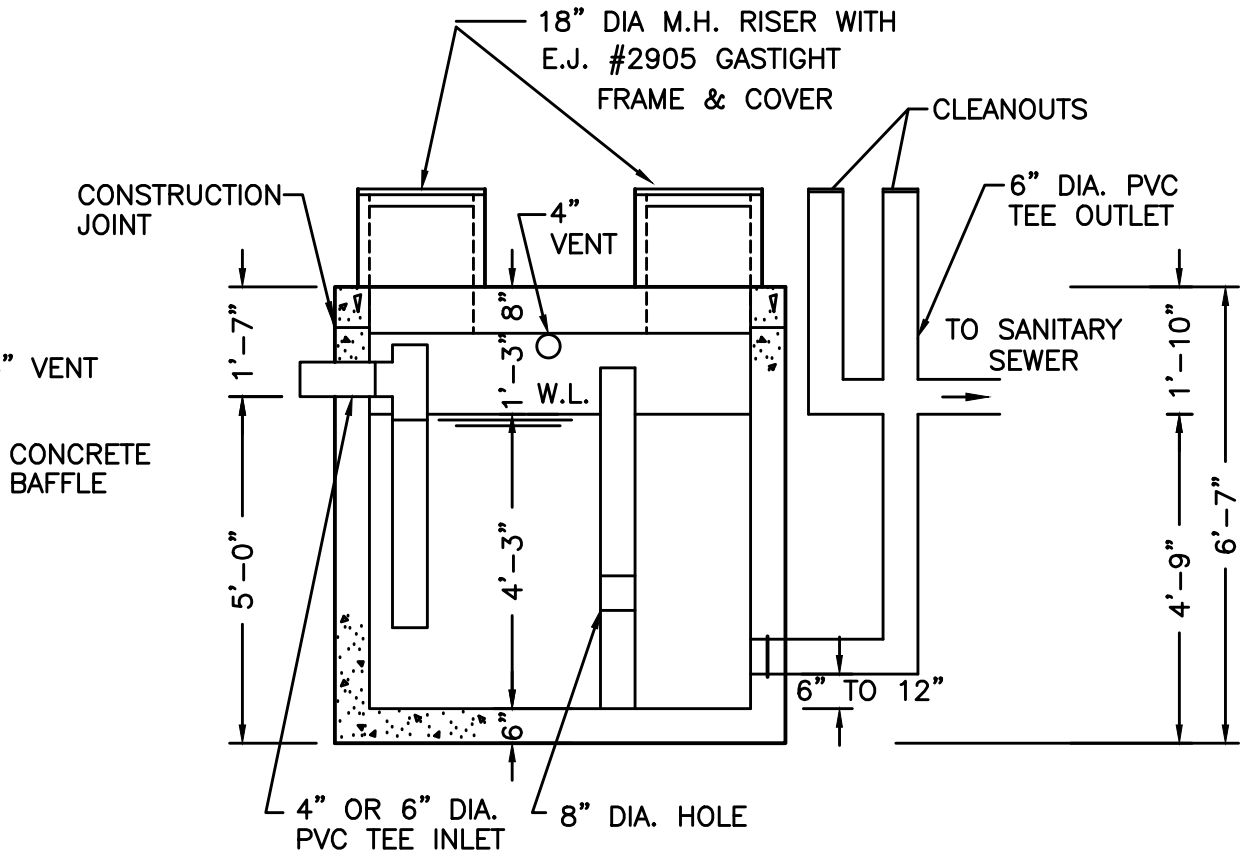

SECTION A-A

NOTES:

1. REINFORCED PRECAST CONCRETE SHALL HAVE A COMPRESSIVE STRENGTH OF 5000 PSI AT 28 DAYS.
2. 18" DIA. RISER AVAILABLE IN 12" + 24" HEIGHTS.
3. CONSTRUCTION JOINT TO BE SEALED WITH 1" CONSEAL CS-101 SEALANT.
4. VENT SHALL BE TERMINATED OUTSIDE AND ABOVE THE HIGHEST FLOOR DRAIN. THE VENT SHALL BE SITUATED SO THAT NO SURFACE WATER ENTERS.
5. ALL PVC PIPES SHALL CONFORM TO ASTM D3034
6. ALL PIPE PENETRATIONS SHALL CONFORM TO ASTM C923 AND SHALL BE A-LOK, KOR-N-SEAL OR APPROVED EQUAL.

BOTTOM OUTLET REQUIRED AS SHOWN TO PREVENT REMOVAL OF AN INTERNAL OUTLET TEE.

CLEANOUTS MUST BE INSTALLED TO FACILITATE BLOCKAGE REMOVAL IN EITHER DIRECTION.

**500 GALLON OIL & WATER SEPARATOR
HEAVY DUTY**

DRAWN BY: ARM	SCALE: 3/8"=1'-0"	DRAWING NO.:
DATE: 10/6/2015	REV:	

(BASED ON MACK INDUSTRIES GREASE TRAP TANK)

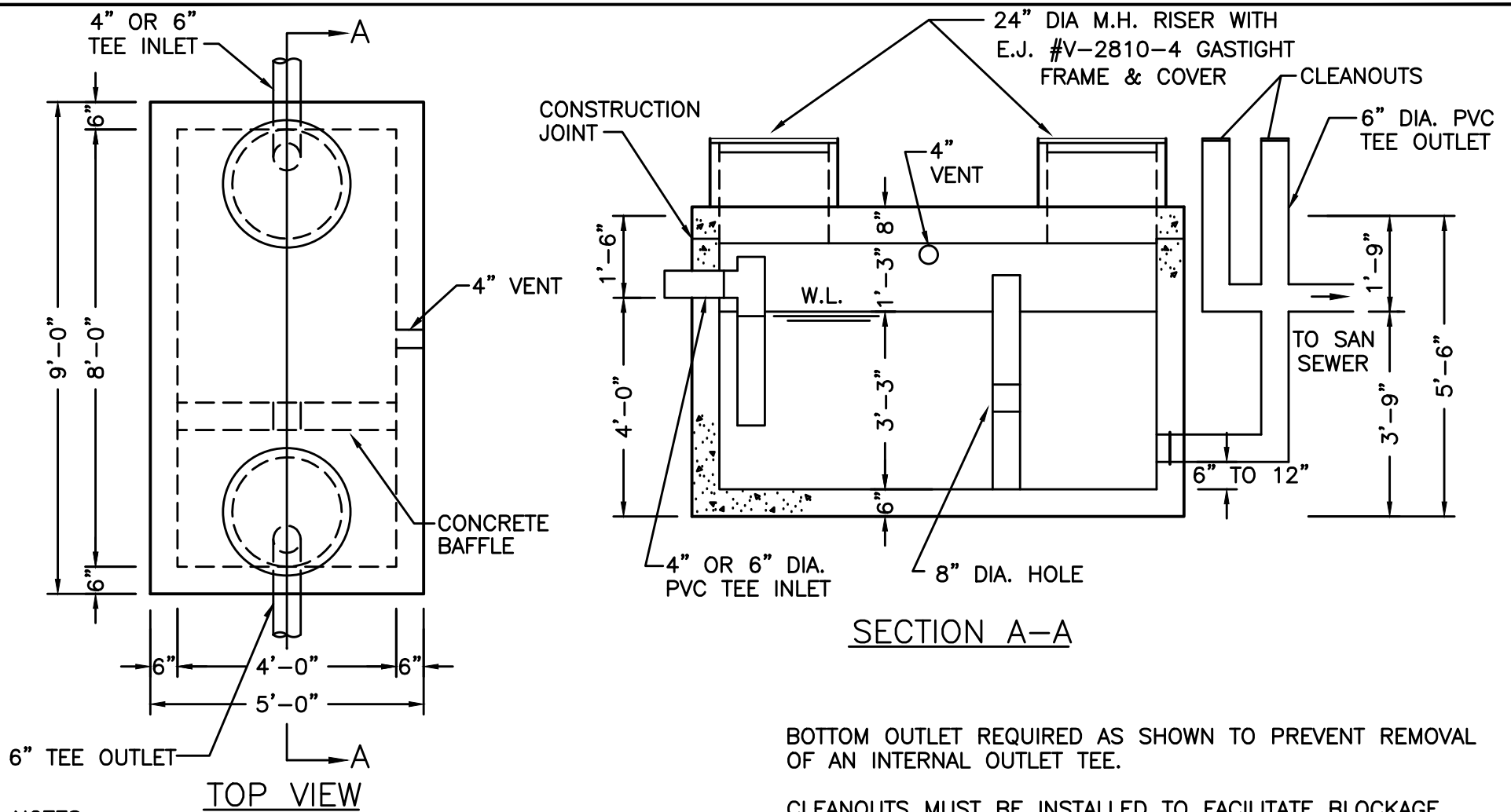

BOTTOM OUTLET REQUIRED AS SHOWN TO PREVENT REMOVAL OF AN INTERNAL OUTLET TEE.

CLEANOUTS MUST BE INSTALLED TO FACILITATE BLOCKAGE REMOVAL IN EITHER DIRECTION.

NOTES:

1. REINFORCED PRECAST CONCRETE SHALL HAVE A COMPRESSIVE STRENGTH OF 5000 PSI AT 28 DAYS.
2. 18" DIA. RISER AVAILABLE IN 12" + 24" HEIGHTS.
3. CONSTRUCTION JOINT TO BE SEALED WITH 1" CONSEAL CS-101 SEALANT.
4. VENT SHALL BE TERMINATED OUTSIDE AND ABOVE THE HIGHEST FLOOR DRAIN. THE VENT SHALL BE SITUATED SO THAT NO SURFACE WATER ENTERS.
5. ALL PVC PIPES SHALL CONFORM TO ASTM D3034
6. ALL PIPE PENETRATIONS SHALL CONFORM TO ASTM C923 AND SHALL BE A-LOK, KOR-N-SEAL OR APPROVED EQUAL.

(BASED ON MACK INDUSTRIES GREASE TRAP TANK)

750 GALLON OIL & WATER SEPARATOR HEAVY DUTY		
DRAWN BY: ARM	SCALE: 3/8"=1'-0"	DRAWING NO.:
DATE: 10/6/2015	REV:	

TOP VIEW

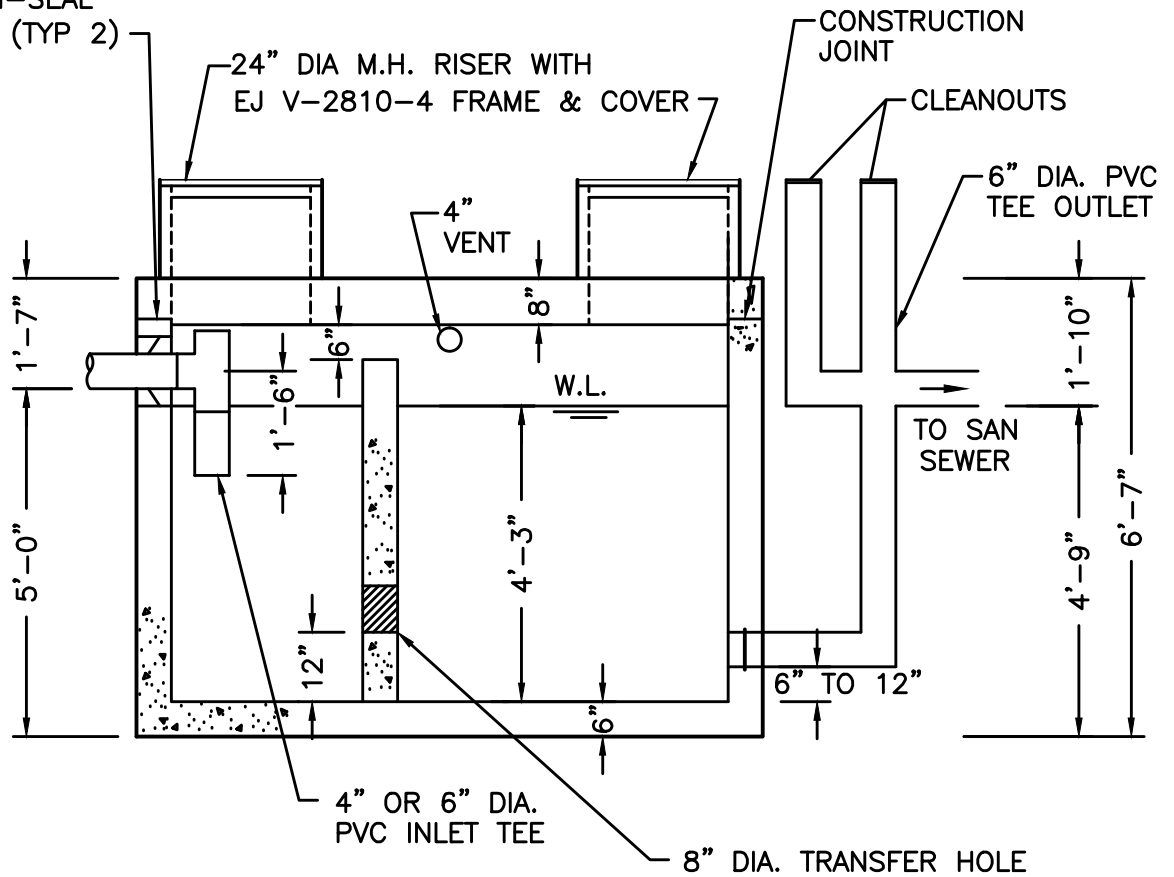
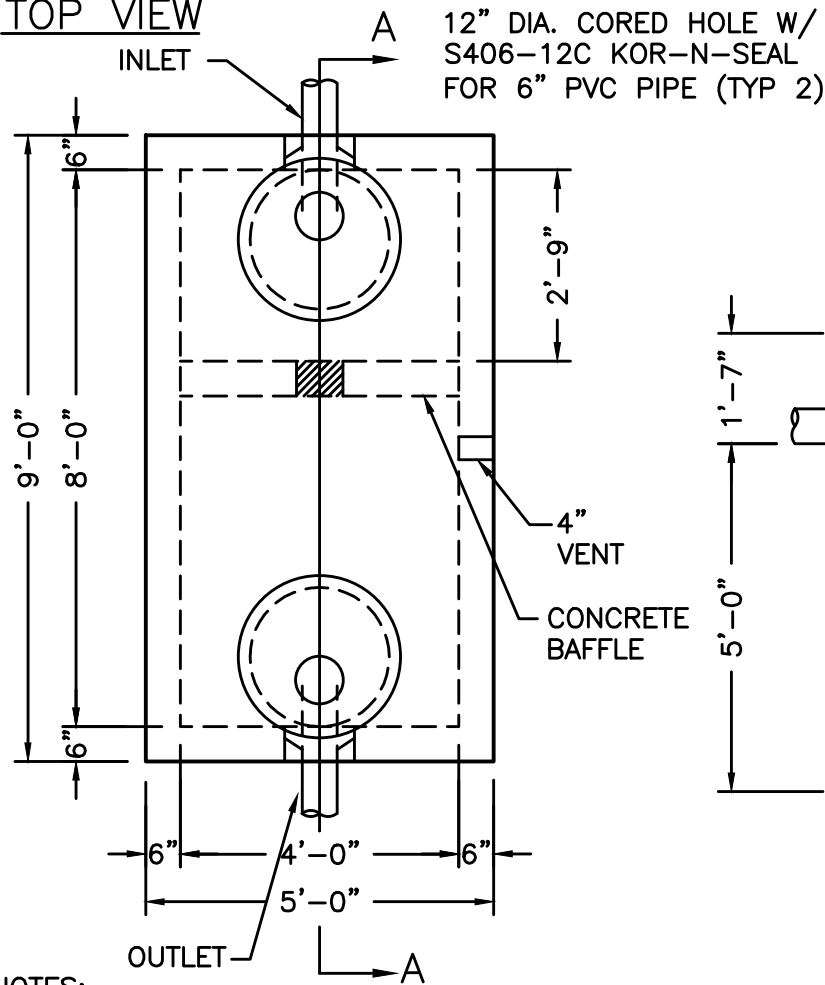

SECTION A-A

BOTTOM OUTLET REQUIRED AS SHOWN TO PREVENT REMOVAL OF AN INTERNAL OUTLET TEE.

CLEANOUTS MUST BE INSTALLED TO FACILITATE BLOCKAGE REMOVAL IN EITHER DIRECTION.

(BASED ON MACK INDUSTRIES GREASE TRAP TANK)

NOTES:

1. REINFORCED PRECAST CONCRETE SHALL HAVE A COMPRESSIVE STRENGTH OF 5000 PSI AT 28 DAYS, AND CONTAIN XYPEX WATERPROOFING ADMIXTURE.
2. CONCRETE REINFORCED TO MEET H-20 LOADING, #5 BARS AT 8" C-C, EACH WAY, CONTINUOUS AROUND CORNERS.
3. 24" DIA. RISER AVAILABLE IN 12", + 24" HEIGHTS.
4. CONSTRUCTION JOINT TO BE SEALED WITH 1" CONSEAL CS-102 SEALANT.
5. VENT SHALL BE TERMINATED OUTSIDE AND ABOVE THE HIGHEST FLOOR DRAIN. THE VENT SHALL BE SITUATED SO THAT NO SURFACE WATER ENTERS.
6. ALL PVC PIPES SHALL CONFORM TO ASTM D3034.
7. ALL PIPE PENETRATIONS SHALL CONFORM TO ASTM C923 AND SHALL BE A-LOK, KOR-NSEAL OR APPROVED EQUAL.

**1000 GALLON OIL & WATER SEPARATOR
STARK COUNTY**

DRAWN BY: ARM

SCALE: 3/8"=1'-0"

DATE: 10/6/2015

REV:

CHAPTER 24

Outdoor Sanitary Connections

24.01 General

The Stark County Metropolitan Sewer District prohibits any form of outdoor connection to the sanitary sewer having the potential to conduct clean water into the sanitary collection system. However, the District recognizes that there may be a limited need for an outdoor connection. These applications are specific and listed below with associated limitations.

24.02 Outdoor Dumpster Drain

Restaurant dumpster storage area drains may be connected to the sanitary sewer with the following conditions:

- 24.02.01 The dumpster must be enclosed by walls on three sides with a door/gate(s) on the fourth side.
- 24.02.02 The enclosed dumpster area must be 100% under roof.
- 24.02.03 All areas surrounding the dumpster enclosure must be graded to drain away from the dumpster area so that no surface storm water shall enter the dumpster enclosure. An asphalt berm shall be constructed along the outside of the door/gate in order to restrict surface storm water flow from entering the enclosure.
- 24.02.04 The sanitary sewer shall drain the entire area within the dumpster enclosure and shall be connected to the facility's grease trap.
- 24.02.05 The dumpster drain shall have a trap installed and may require a vent to properly drain. All building codes shall be followed in plumbing the outdoor drainage system.
- 24.02.06 All facilities that utilize a dumpster drain will be charged an additional 0.5 SFE for the service.

24.03 Street Sweeping Containment Drain

In order to satisfy the Clean Water Act, drainage from street sweeping areas shall not flow into normal storm water conveyance systems. The drainage should be treated at a wastewater treatment facility. The Stark County Metropolitan Sewer District will allow street sweeping drainage into its collection system with the following limitations:

- 24.03.01 The street sweeping containment area must be enclosed by walls on three sides with a gate(s) on the fourth side.
- 24.03.02 The enclosed street sweeping containment area must be 100% under roof. The roof may be removable temporarily to allow dumping and cleaning or high enough to allow these activities, however, in the case of a high permanent roof, the roof must cover 20% more than the enclosed area to restrict blowing precipitation.
- 24.03.03 All areas surrounding the street sweeping containment enclosure must be graded to drain away from the enclosure so that no surface storm water shall enter the enclosed street sweeping containment area. An asphalt berm shall be constructed along the outside of the gate(s) in order to restrict surface storm water flow from entering the enclosure.

- 24.03.04 The sanitary sewer shall drain the entire area within the enclosed street sweeping containment area and shall be connected to the facility's building sewer line.
- 24.03.05 The enclosed street sweeping containment drain shall have a trap installed and may require a vent to properly drain. All building codes shall be followed in plumbing the outdoor drainage system.
- 24.03.06 The enclosed street sweeping containment area drain must be protected with a grate that will exclude solids greater than ½ - inch. Grit entrapment must be included in the containment area design.
- 24.03.07 All facilities that utilize an enclosed street sweeping containment area drain will be charged for the service contingent upon the square foot area of enclosed drainage site.

End of Chapter

CHAPTER 25

Petition Process for Sanitary Sewers

25.01 Introduction

25.01.01 Within parameters set forth in the Ohio Revised Code, the Board of Stark County Commissioners (SCC) is authorized to construct sanitary sewers where it finds that they are necessary to preserve and promote the public health and welfare. In order to properly evaluate the necessity for a specific project, the current state of public health and welfare, and the public interest in a specific project, there is hereby created a petition process for the purpose of invoking the Board's consideration of the necessity of the project petitioned for.

25.02 Petition Initiation (Phase I)

25.02.01 The boundary of the service area of the Stark County Metropolitan Sewer District, as prescribed in the State of Ohio's 208 Clean Water Plan, is not co-terminus with the boundary of the District. No petition for a sanitary sewer project located outside of the service area will be considered until that territory is added to the service area by resolution of the Board. No petition for sanitary sewer located, in whole or in part, inside a municipal corporation will be considered until such consideration is requested by resolution or ordinance of the municipality's legislative body.

25.02.02 Upon request by a person or persons interested in obtaining sanitary sewer service, the Sanitary Engineer will undertake to analyze the property and neighboring territory to determine the feasibility of the requested project. Feasibility will be evaluated using the following criteria:

- 1) Availability; the reasonable proximity of the petitioned territory for connection to an existing sewer.
- 2) Capacity; the ability within the existing sewer facilities to accept flows from the petitioned territory.
- 3) Methodology; the necessary method of service, whether by connection to an existing sewer trunk by gravity or sanitary lift station; or treatment of wastewater generated within the territory by a stand-alone wastewater treatment plant.
- 4) Affordability; the cost of the petitioned project in relation to the cost to property owners under the Board's assessment resolution, the cost/benefit ratio of potential customers served and the overall size of the project.

25.02.03 If the project is determined to be feasible, the Sanitary Engineer will establish a Petition Area. The Petition Area will be determined by: (1) the number of properties that can physically be served by gravity sewer, (2) the amount of capacity available in the general sewer shed, (3) the required method of wastewater disposal, (4) the number of properties that can be reasonably assessed to make the project affordable.

25.02.04 The Sanitary Engineer will prepare an initial Petition Area plan, determine the assessment boundary for the petitioned territory and note the addresses of all owners

to be canvassed.

The Sanitary Engineer may adjust the Petition Area at any time during the Petition process. All participants in the previous and proposed petition areas will be informed of any change prior to the next step of the process.

25.03 Petition Process

25.03.01 Following preparation of the petition by the Sanitary Engineer, the petition document will be delivered to the interested party (the petitioner), either at the office of the Sanitary Engineer or by regular US mail.

25.03.02 The petitioner will be provided an informational sheet to distribute to property owners in the Petition Area outlining this process. The petitioner will be instructed as to obtaining signatures expressing interest from property owners.

25.03.03 The petitioner will have six (6) months from the date of delivery of the petition (either the date received in person or the date of mailing) in which to circulate the petition and obtain signatures of at least 70% of property owners within the Petition Area. The expiration date will be indicated on the petition.

25.03.04 If, after six (6) months from the date of delivery of the petition to the petitioner, the petitioner has not delivered to the Sanitary Engineer the petition containing the signatures of at least 70% of property owners within the Petition Area, the petition effort will have failed. No subsequent petition encompassing all or any part of the Petition Area will be prepared or accepted for consideration until the passage of eighteen months from the date the original petition was delivered to the petitioner.

25.03.05 Public Information Meeting (Phase II)

1) Upon receipt of a petition containing the signatures of 70% of the property owners in the Petition Area, the Sanitary Engineer will schedule a neighborhood meeting to discuss the details of the proposed sanitary sewer project. Notice of the meeting, together with a card upon which an owner may express a preference for or against the sewer project, will be sent to all affected residents. Subjects discussed at the meeting will include:

- a. The petition area and how the area was determined
- b. A preliminary drawing (not the final design) of the proposed sewer alignment
- c. Estimated project costs
- d. Estimated aggregate assessment to property owners
- e. Ancillary costs to property owners, including connection charge, drain layer costs, assessment charge and monthly service fee.
- f. Proposed Construction Schedule
- g. General Questions

- h. Explanation of the preference cards, which will be used to determine if the residents are willing to accept and finance a sanitary collection system
 - Cards may be turned in at the end of the meeting or taken home and mailed later.
 - All cards must be postmarked by the end of the day referred to in the neighborhood meeting notice.
 - Additional cards will be available at the meeting.
 - Cards will be tallied at the office of the Sanitary Engineer and if the preferences “in favor” exceed 50%, the project will continue to Phase III.
 - If no card is returned, it is assumed the individual is opposed to the Project.
- 2) Upon receipt of a petition containing the signatures of 70% of the property owners in the Petition Area which lies, in whole or in part, within a municipal corporation, the Sanitary Engineer will not schedule a neighborhood meeting until the municipal corporation has adopted an ordinance or resolution in accordance with Revised Code § 6117.04 authorizing the acquisition, construction, maintenance, and operation of the sanitary sewer facilities proposed, and any adjustments necessary for compliance with the 208 Clean Water Plan.

25.03.06 Project Preparation (Phase III)

- 1) Upon expression of preference by more than 50 % of property owners in the petitioned territory in favor of the petitioned sewer project, the Board may adopt a resolution authorizing the Sanitary Engineer to prepare detailed plans, specifications and tentative assessments.
- 2) In accordance with the Ohio Revised Code, upon consideration of the detailed plans, specifications and tentative assessments, the Board may adopt a resolution declaring that the improvement is necessary for the preservation and promotion of the public health and welfare, and determining whether or not special assessments are to be levied and collected to pay any part of the cost of the improvement.
- 3) Upon the adoption of a resolution of necessity for the petitioned sewer, the project will proceed in accordance with Ohio statute, regulations of Ohio and U.S. EPA and existing agreements between the Board and other political subdivisions or municipal corporations.

End of Chapter