

**OHIO ADMINISTRATIVE CODE**  
**CHAPTER 3701-29**



**Department  
of Health**

**SEWAGE TREATMENT SYSTEM RULES**

**OHIO DEPARTMENT OF HEALTH**  
**Bureau of Environmental Health and Radiation**  
**Protection**

**JANUARY 1, 2015**

(OAC 3701-29-13 revised effective September 30, 2019)

**OHIO DEPARTMENT OF HEALTH  
OHIO ADMINISTRATIVE CODE CHAPTER 3701-29  
SEWAGE TREATMENT SYSTEM RULES**

**TABLE OF CONTENTS**

		Page No.
3701-29-01	Definitions .....	2
3701-29-02	Scope, responsibility for compliance, and applicability of rules .....	11
3701-29-03	Registration of installers, service providers, and septage haulers .....	13
3701-29-04	Survey to determine compliance .....	17
3701-29-05	Fees and fee categories .....	19
3701-29-06	General provisions and prohibitions .....	21
3701-29-07	Soil evaluation and soil evaluators .....	25
3701-29-08	Subdivisions and new lots .....	28
3701-29-09	Site review and permits for STS installation and operation .....	30
3701-29-10	STS designers and designs .....	35
3701-29-11	Flow estimation and waste strength .....	37
3701-29-12	Tanks, pumps and controls, and building sewers .....	39
3701-29-13	Product standards and approval .....	45
3701-29-13 Appendix A	Low Pressure Dosed Sand Filter .....	50
3701-29-13 Appendix B	Time Dosed Sand Filter .....	64
3701-29-14	Effluent quality standards .....	72
3701-29-15	General soil absorption standards .....	73
3701-29-15.1	Low Pressure Distribution .....	82
3701-29-15 Appendix A	Leaching Trenches .....	85
3701-29-15 Appendix B	Sand Mounds .....	90
3701-29-15 Appendix C	Drip Distribution .....	95
3701-29-16	Site drainage .....	100
3701-29-16 Appendix A	Engineered Drainage .....	103
3701-29-17	Gray water recycling systems .....	107
3701-29-18	Privies and holding tanks .....	111
3701-29-19	STS operation and management, and owner education .....	112
3701-29-20	Septage and sewage management .....	115
3701-29-21	STS abandonment .....	118
3701-29-22	Variances and more stringent standards .....	120
3701-29-23	Verification of compliance, enforcement and hearings .....	121

**3701-29-01 Definitions.**

As used in this chapter:

- (A) "AASHTO" mean the American association of state highway and transportation officials.
- (B) "Alter" or "Alteration" means the same as division (A) of section 3718.01 of the Revised Code. For the purposes of this chapter, the terms "alter" or "alteration" shall include, but not be limited to a change in the nature of influent waste strength; a change in system components; an expansion of the treatment or dispersal system, and may include a change in the volume of the daily design flow.
- (C) "ANSI" means the American national standards institute.
- (D) "Approved Leaching Trench Products Utilizing a Non-gravel Fines-Free Distribution System" means products which have received the approval of the director through one of the two processes described in rule 3701-29-13 of the Administrative Code.
- (E) "Aquifer" means a consolidated or unconsolidated geologic formation or series of formations that are hydraulically interconnected and that have the ability to receive, store, or transmit water.
- (F) "ASTM" means the American society for testing and materials or ASTM international.
- (G) "Average Daily Flow" means the actual average flow of sewage through the sewage treatment system in a twenty-four hour period, typically assumed to be sixty per cent of the daily design flow.
- (H) "Bedrock" means hard stratum that underlies unconsolidated surface materials or soil.
- (I) "Bedroom" means a room that is designed or used as a sleeping room or any room that that could reasonably be used as or finished as a sleeping room as determined by the board of health. The board of health may consider the room's architectural features when making the determination.
- (J) "Biochemical oxygen demand, five-day" or "BOD<sub>5</sub>" means the quantitative measure of the amount of oxygen consumed by bacteria while stabilizing, digesting, or treating biodegradable organic matter under aerobic conditions over a five-day incubation period; expressed in milligrams per liter (mg/L).
- (K) "Board of health" means the board of health of a city or general health district or the authority having the duties of a board of health in any city as authorized by section 3709.05 of the Revised Code, or the authorized representative of such a board or authority.
- (L) "Black water" means the portion of the wastewater stream that originates from toilet fixtures, dishwashers, dish sinks, and food preparation sinks.
- (M) "BNQ" means bureau de normalisation du Quebec
- (N) "Carbonaceous biochemical oxygen demand" or "CBOD<sub>5</sub>" means an index of the amount of oxygen that will be consumed by the decomposition of organic matter in sewage. The CBOD<sub>5</sub> test is one of the commonly used indicators of waste strength.
- (O) "CEN" means European committee for standardization
- (P) "Cesspool" means an excavation (deeper than it is wide) which receives sewage and from which the sewage seeps into the surrounding soil through the bottom and openings in the side of the pit.
- (Q) "CFU" means the number of bacteria colony forming units, or colonies, or individual bacteria that can be counted or estimated in a membrane filter coliform test.

- (R) "Coarse aggregate" means materials that meet AASHTO Standard M43 sizes four through fifty-seven and shall be washed with not more than five per cent passing the number two hundred (seventy-five micrometers) sieve as determined by ASTM C117, "Test Method for Material Finer than 75- $\mu$ m (No. 200) Sieve in Mineral Aggregates by Washing" and shall be durable with a hardness of three or greater on the Moh's scale of hardness.
- (S) "Component" means an independent portion of the sewage treatment system. Sewage treatment system components include, but are not limited to, septic tanks, approved pretreatment products, tertiary treatment, and soil absorption.
- (T) "Composting toilet" means a system designed to store and compost human urine and feces primarily by unsaturated, aerobic microbial digestion to a stable soil-like material called "humus." These systems are commonly designed to accommodate fecal and urinary wastes, toilet paper and small amounts of organic carbonaceous material added to assist their function.
- (U) "CSA" or "CAN/CSA" means the Canadian standards association or CSA international.
- (V) "Cut bank" means a steep slope formed typically by stream erosion or construction.
- (W) "Daily design flow" means the peak estimated volume of sewage for any twenty-four hour period received by a STS used for system design.
- (X) "Department of health" means the department of health of the state of Ohio.
- (Y) "Designer" means a person who creates plans for the installation, alteration, repair or replacement of a sewage treatment system or a gray water recycling system.
- (Z) "Device" means an approved sub-unit of a sewage treatment system component. For example, agitators and blowers are devices in a pretreatment component, and distribution boxes, drop boxes, and lift stations are devices in a soil absorption component.
- (AA) "Director of health" means the director of the department of health of the state of Ohio and includes any authorized representative of the director.
- (BB) "Distribution" means the process of conveying sewage or effluent to one or more components or devices.
- (CC) "Domestic septage" means the liquid or solid material removed from a sewage treatment system, composting or portable toilet, privy, sewage holding tank, holding tanks for campers and recreational vehicles, or type III marine sanitation device as defined in 33 C.F.R. 159.3. Domestic septage does not include grease removed from a grease trap.
- (DD) "Drainage" or "dry well" means an excavation or structure (deeper than it is wide) which receives liquids and from which the liquid seeps into the surrounding soil through the bottom and openings in the side of the pit.
- (EE) "DRAINMOD" means a computer simulation model developed at North Carolina State University, in Raleigh, North Carolina. The model simulates the hydrology of poorly drained, high water table soils on an hour-by-hour, day-by-day basis for long periods of climatological records. The model predicts the effects of drainage and associated water management practices on water table depths, the soil water regime and crop yields.
- (FF) "Dwelling" means the place which is occupied by a person or persons as their primary residence or secondary residence that may be seasonal or recreational.

- (GG) “Effective size” or “D<sub>10</sub>” means particle diameter of which ten per cent of the sample is finer by weight as determined by a sieve analysis.
- (HH) “Effluent” means liquid flowing out of a STS component or device.
- (II) “Engineered drainage system” means a drainage system designed to meet the specifications of paragraph (F) of rule 3701-29-16 of the Administrative Code.
- (JJ) “Fecal coliform” means bacteria common to the digestive systems of warm-blooded animals that are cultured in standard tests. Counts of these organisms are typically used to indicate potential contamination from sewage or effluent or to describe a level of needed disinfection.
- (KK) “Fill soil” means human-constructed deposits of natural earth material derived from soil that has been moved from its naturally occurring position or place.
- (LL) “Fine earth” means soil that can pass a two millimeter sieve.
- (MM) “Fine textured soil” means soil with a USDA soil textural class of sandy clay, silty clay or clay.
- (NN) “Flood plain” or “special flood hazard area” means the land in the floodplain subject to a one per cent or greater chance of flooding in any given year, otherwise known as the one hundred-year flood plain. Special flood hazard areas are designated by the federal emergency management agency on flood insurance rate maps, flood insurance studies, flood boundary and floodway maps and flood hazard boundary maps as zones A, AE, AH, AO, A1-30, and A99. Special flood hazard areas may also refer to areas that are flood prone and designated from other federal, state, or local sources of data including but not limited to historical flood information reflecting high water marks, previous flood inundation areas, and flood prone soils associated with a watercourse as defined in Chapter 1521. of the Revised Code.
- (OO) “Flood way” as defined in Chapter 1521. of the Revised Code means the channel of a river or other watercourse and the adjacent land areas that have been reserved in order to pass the base flood discharge. A floodway is typically determined through a hydraulic and hydrologic engineering analysis such that the cumulative increase in the water surface elevation of the base flood discharge is no more than a designated height. The floodway is an extremely hazardous area, and is usually characterized by, but is not limited to, any of the following: moderate to high velocity flood waters, high potential for debris and projectile impacts, or moderate to high erosion forces.
- (PP) “Flow restrictive layer” means a layer above which saturated flow is expected to move primarily laterally, such as:
- (1) A layer that has an infiltrative loading rate of “0” on Table 3 of rule 3701-29-15 of the Administrative Code;
  - (2) Fine textured soils composed of primarily smectite or other highly expansive clays with weak to no structure or which have slow to very slow permeability in addition to expansive clays;
  - (3) A layer with greater than sixty per cent rock fragment size particles where the spaces between the rock fragments are primarily filled with fine textured soils;
  - (4) Bedrock that is deemed by the soil evaluator to be relatively impermeable and free of fractures; or

- (5) Any other layer deemed restrictive by the soil evaluator including but not limited to dense glacial till, dense lacustrine deposits, fragipans, compacted soil, or soil with a consistence stronger than firm or hard that is not well drained.
- (QQ) "Gray water" means wastewater discharged from lavatories, bathtubs, showers, clothes washers, and laundry sinks that does not contain food wastes or urine or fecal matter.
- (RR) "Gray water recycling systems" or "GWRS" means systems that treat and reuse or recycles back into the environment wastewater discharged from lavatories, bathtubs, showers, clothes washers, and laundry sinks that does not contain food wastes or bodily wastes. For the purposes of this chapter, bodily waste is considered to be human urine or fecal matter.
- (SS) "Gravity Distribution" means using the force of gravity to convey effluent to one or more components or devices; gravity distribution to trenches may be parallel or sequential.
- (TT) "Ground water" means all water occurring in an aquifer.
- (UU) "Hardscape" means any constructed surface area on the landscape of a site such as a driveway, parking area, patio, building slab, or other similar surface area.
- (VV) "Highly permeable material" means a layer through which effluent is expected to pass too quickly to provide adequate treatment, such as:
- (1) Soils with greater than fifteen per cent rock fragment size particles and a soil texture of: loamy sand, loamy coarse sand, coarse sand, sand, fine sand or very fine sand;
  - (2) Soils with greater than sixty per cent rock fragment size particles and the spaces between the rock fragments are filled with air, or soils other than fine textured soil; or
  - (3) Any other layer deemed by the soil evaluator as highly permeable material.
- (WW) "Household sewage treatment system" or "HSTS" means any sewage treatment system, or part of such a system, that receives sewage from a single-family, two-family, or three-family dwelling. For the purposes of this chapter structures that are served by a household sewage treatment system shall also include:
- (1) A dwelling and related structure, such as a barn or personal garage, when the users of the structure are only the residents of the dwelling, and provided the related structure is not used as a dwelling.
  - (2) A dwelling with a home business when the nature of the home business is such that it does not produce sewage.
  - (3) Vacation rental cabins, provided there is a separate HSTS for each cabin.
  - (4) A bed and breakfast, residential facility, or other residence as described in divisions (B)(2), (B)(4), and (B)(13) of section 3717.42 of the Revised Code.
  - (5) Group homes occupied by no more than sixteen unrelated individuals, including, but not limited to, a hospice and pediatric respite care facility as defined in rule 3701-19-01 of the Administrative Code, a foster home, group home, group home for children, Indian foster home, residential facility, children's residential center, or residential parenting facility as defined in Chapter 5101:2-1 of the Administrative Code, or a type A home as defined in rule 5101:2-13-02 of the Administrative Code, a residential facility defined in rule 5122-30-03 of the Administrative Code, or a residential facility defined in section 5123.19 of the Revised Code.

- (XX) "Hydraulic linear loading rate" or "HLLR" means the volume of effluent applied daily along the landscape contour expressed in gallons per day per linear foot. The HLLR is used to determine the required length of the distribution system parallel to surface contours.
- (YY) "Hydraulically connected" means a condition where a highly permeable material is connected to an aquifer and allows free movement of water or effluent under a hydraulic gradient.
- (ZZ) "IAPMO" means the international association of plumbing and mechanical officials.
- (AAA) "In situ soil" means soil in its naturally deposited location or reclaimed or fill soils that have developed pedogenic features adequate to treat and disperse wastewater.
- (BBB) "Incinerating toilets" means self-contained components that reduce non-water-carried human urine and feces to ash and vapor, including the necessary venting, piping, electrical, and/or mechanical devices. The process is fueled by gas, fuel oil, or electricity.
- (CCC) "Infiltrative distance" means the distance from the level where the effluent enters the in situ soil to level of the uppermost limiting condition.
- (DDD) "Infiltrative surface" means the point or area of application of effluent to the soil or sand fill for purposes of treatment, dispersal, or both.
- (EEE) "Inspection" means the on-site evaluation or analysis of the design, installation, and operation of a sewage treatment system.
- (FFF) "Installer" means any person who engages in the business of installing or altering or who, as an employee of another, installs or alters any sewage treatment system or gray water recycling system.
- (GGG) "Instantaneous loading rate" means volume of effluent discharged from each orifice during a dosing event in a pressurized distribution system measured in gallons per dose per orifice.
- (HHH) "Interceptor drain" means a drain designed to intercept the horizontal flow of subsurface water to reduce its impact on a down gradient soil absorption component
- (III) "Limiting condition" means a flow restrictive soil layer, bedrock, a water table, seasonal water table, ground water or highly permeable material that limits or precludes the treatment or dispersal of effluent in the soil of a property where a sewage treatment system is located.
- (JJJ) "Lot" means a legally recorded parcel of land.
- (KKK) "Low pressure distribution" means application of effluent over an infiltrative surface via pressurized orifices and associated devices and parts including pumps, filters, controls, valves, and piping.
- (LLL) "Manufacturer" means any person that manufactures sewage treatment systems, or components or devices within a sewage treatment system.
- (MMM) "Monitoring" means the activity of verifying performance requirements and may include, but is not limited to, sampling of effluent from, or inspection of a sewage treatment system component. For the purpose of this chapter, monitoring activities shall be conducted by either the board of health or a registered service provider.
- (NNN) "NPDES" means national pollutant discharge elimination system.

- (OOO) "NRCS" means the natural resources conservation service.
- (PPP) "NSF" means national sanitation foundation or NSF international.
- (QQQ) "O&M" means operation and maintenance.
- (RRR) "Ohio EPA" means Ohio environmental protection agency
- (SSS) "Order one soil survey" means a first order soil survey as described in chapter two of the NRCS, soil survey manual.
- (TTT) "Owner" means the owner of the sewage treatment system or the property where a proposed sewage treatment system is to be installed.
- (UUU) "Parallel Distribution" means pressure or gravity distribution of effluent that proportionally and simultaneously loads multiple sections of a treatment and/or dispersal component.
- (VVV) "Perennial stream" means natural waters of the state with a defined stream bed and bank and constant source of flowing water.
- (WWW) "Perimeter drain" means a subsurface drain installed around a soil absorption component that is designed to enhance drainage of the area. A perimeter drain does not uniformly lower the seasonal water table beneath a soil absorption area to increase the vertical separation distance.
- (XXX) "Person" includes an individual, corporation, business trust, estate, trust, partnership, and association as set forth in section 1.59 of the Revised Code and also includes any state, any political subdivision of a state, and any department, division, board, commission, agency, or instrumentality of a state or political subdivision.
- (YYY) "Portable toilet" means a waterless toilet with a tank that typically contains a chemical to limit decomposition of non-water-carried human excreta during storage prior to pumping.
- (ZZZ) "Pretreatment components" means manufactured or built components of a STS that are designed to reduce contaminants, nutrients, or biological agents from sewage to produce a higher quality effluent. For the purposes of this chapter pretreatment component does not include a septic tank, but does include products designed to be placed within an existing septic tank.
- (AAAA) "Privy" means a self-contained waterless toilet used for disposal of non-water-carried human excreta that consists of a shelter built above an approved tank installed in the ground into which human excreta is deposited.
- (BBBB) "Repair" means act of fixing or replacing substandard or damaged devices to restore a sewage treatment system or component to proper working condition, and does not require a permit.
- (CCCC) "Replacement" means the installation of a new sewage treatment system to replace an existing system. For the purposes of this chapter, the replacement or relocation of a soil absorption component or the treatment component providing the majority of the treatment shall be considered a replacement. For the purposes of this chapter, the addition of a treatment component to a discharging system not currently under a NPDES permit shall be considered a replacement.
- (DDDD) "Replacement area" means an area identified and set aside during the development of a site that is sufficient for the installation of a replacement STS.
- (EEEE) "Responsible management entity" means a person other than the owner of the property served by the STS that has assumed the managerial, financial, and technical responsibilities of the STS to



ensure the long-term, operation in accordance with this chapter, including but not limited to water and sewer districts, government entities, and utility or private management companies.

- (FFFF) “Rock fragments” means unattached pieces of geologic or pedogenic material, two millimeters in diameter or larger that are strongly cemented or more resistant to rupture.
- (GGGG) “Safety hazard” means the presence of conditions that, if left uncontrolled, can result in (present a risk of) bodily harm or death including, but not limited to: unsecured electrical devices or wiring; collapsed, deteriorated, or cracked devices or components; collapsed, deteriorated, cracked, missing or unsecured device or component covers; and unsecured, open excavations.
- (HHHH) “Sanitary sewerage system” means pipelines or conduits, pumping stations, force mains, and all other constructions, devices, appurtenances, and facilities that convey sewage to a central sewage treatment plant and that are required to obtain a permit under Chapter 6111. of the Revised Code.
- (IIII) “Seasonal water table” means soil that has water seasonally occupying one hundred per cent of the void spaces indicated by greater than or equal to five per cent redoximorphic depletions with soil colors of two chroma or less that is not hydraulically connected to an aquifer.
- (JJJJ) “Septage hauler” means any person who engages in the collection, transportation, disposal, and/or land application of domestic septage. A septage hauler may also evaluate and report on the condition of any tank they are pumping.
- (KKKK) “Septic tank” means a water-tight, covered receptacle for treatment of sewage that receives the discharge of sewage from a building, separates settleable and floating solids from the liquid, digests organic matter by anaerobic bacterial action, stores digested solids through a period of detention, allows clarified liquids to discharge for additional treatment and final dispersal, and attenuates flows.
- (LLLL) “Sequential distribution” means distribution method in which effluent is loaded into one trench and fills it to a predetermined level before passing through a relief line or device to the succeeding trench; the effluent does not pass through the distribution media of the preceding trench before it enters succeeding trenches.
- (MMMM) “Serial distribution” means distribution method in which effluent is loaded into one trench and fills it to a predetermined level before passing through a relief line or device to the succeeding trench; effluent passes through the distribution media before entering succeeding trenches which may be connected to provide a single uninterrupted flow path.
- (NNNN) “Service and maintenance” means all routine or periodic action taken to assure that an existing sewage treatment system operates as it was intended including the in-place correction, cleaning, or replacement of damaged or worn out devices with approved devices. Service and maintenance shall include the replacement of mechanical devices such as agitators, compressors, and pumps; replacement of broken device lids, risers, and baffles; the installation or cleaning of an outlet filter; the pumping of a sewage treatment system component by a registered septage hauler; and all other actions not defined as an alteration or replacement, as determined by the board of health.
- (OOOO) “Service provider” means any person who services, monitors, evaluates or samples, but does not install or alter, sewage treatment systems or gray water recycling systems. For the purpose of this chapter, service provider shall include a homeowner servicing his own system to meet the requirement of a service contract for product approval or demonstration of maintenance for an O&M program established in accordance with rule 3701-29-19 of the Administrative Code.
- (PPPP) “Sewage” means liquid waste containing animal or vegetable matter in suspension or solution that originates from humans and human activities. Sewage includes liquids containing household

chemicals in solution commonly discharged from a residence or from commercial, institutional, or other similar facilities.

- (QQQQ) "Sewage treatment system" or "STS" means a household sewage treatment system, a small flow on-site sewage treatment system, or both, as applicable.
- (RRRR) "Small flow on-site sewage treatment system" or "SFOSTS" means a system, other than a household sewage treatment system that treats not more than one thousand gallons of sewage per day and that does not require a national pollutant discharge elimination system permit issued under section 6111.03 of the Revised Code or an injection well drilling or operating permit issued under section 6111.043 of the Revised Code. For the purposes of this chapter, structures that are served by a small flow on-site sewage treatment system shall also include:
- (1) More than one dwelling or arrangements such as a dwelling and a detached garage with living space.
  - (2) More than one vacation rental cabin.
  - (3) A dwelling and related structure, such as a barn or personal garage, when the structure is used by persons other than, or in addition to the residents of the dwelling.
  - (4) A dwelling with a home business when the nature of the home business is such that it produces sewage, including but not limited to, home businesses that provide a public restroom for use by nonresidents.
- (SSSS) "Soil" means the naturally occurring pedogenically developed and undeveloped regolith overlying bedrock.
- (TTTT) "Soil depth credit" means the use of the design mechanisms of elevation, pretreatment, and/or distribution as substitutes for all or a portion of the required in situ soil treatment to compensate for insufficient vertical separation distance within the infiltrative distance.
- (UUUU) "Soil evaluator" means a person who conducts an evaluation of the soil for the purpose of siting and designing an STS.
- (VVVV) "Soil infiltration loading rate" or "SILR" means the daily volume of effluent applied per unit area of in situ soil expressed in gallons per day per square foot. The "soil infiltration loading rate" may also be referred to as the basal loading rate or the infiltration loading rate. The soil infiltration loading rate determines the minimum square footage of the soil absorption area.
- (WWWW) "Soil texture" means the USDA description of soil based on the relative proportion of sand, silt and clay in the soil.
- (XXXX) "Subdivision" means that which is defined by section 711.001 of the Revised Code.
- (YYYY) "Surge capacity" means the tank capacity located between the reserve capacity and maximum drawdown point.
- (ZZZZ) "TAC" means the sewage treatment systems technical advisory committee established in section 3718.03 of the Revised Code.
- (AAAAA) "Tank capacity" means the storage capacity of a sewage tank or tanks.
- (BBBBB) "Timed dosing" means delivery of discrete volumes of effluent at prescribed time intervals.

- (CCCCC) "Topsoil" means the upper most part of the soil commonly referred to as the plow layer, the A layer, the A horizon, or its equivalent in uncultivated soils.
- (DDDDD) "Total suspended solids" or "TSS" means the dispersed particulate matter in a sewage sample that may be retained by a filter medium. Suspended solids may include both settleable and unsetttable solids of both inorganic and organic origin.
- (EEEEEE) "Treatment train" means an approved combination of treatment processes and components that are combined together in sequence to treat sewage to a specified effluent quality standard.
- (FFFFF) "UIC" means underground injection control and relates to the Ohio EPA underground injection control program authorized by sections 6111.043 and 6111.044 of the Revised Code.
- (GGGGG) "UL" means underwriters laboratories incorporated.
- (HHHHH) "Uniformity coefficient" or "UC" means a ratio of the uniformity of a mixture of sand particles calculated by dividing the size of the opening where sixty per cent of a sample passes by the size of the opening where ten per cent of a sample passes on a weight basis. The higher the UC, the less uniform the sand.
- (IIIII) "Update" means changing any discharging HSTS that was installed prior to January 1, 2007 that uses a system/manufacturer model that has been approved by the director to meet the conditions of the general household NPDES permit issued by Ohio EPA absent post aeration, disinfection, and/or sampling mechanisms and can be updated to be an identical system to such approved by the director by installing these additional components.
- (JJJJJ) "USDA" means the United States department of agriculture.
- (KKKKK) "USEPA" means the United States environmental protection agency.
- (LLLLL) "Vertical separation distance" or "VSD" means the distance from the level of the infiltrative surface of the distribution system of a soil absorption system, or component thereof, to the level of a limiting condition in the soil.
- (MMMMM) "Water table" means the surface of the saturated zone below which all interconnected voids are filled with water and at which the pressure is atmospheric.
- (NNNNN) "Waters of the state" means that which is defined in division (H) of section 6111.01 of the Revised Code as all streams, lakes, ponds, marshes, watercourses, waterways, wells, springs, irrigation systems, drainage systems, and other bodies or accumulations of water, surface and underground, natural or artificial, regardless of the depth of the strata in which underground water is located, that are situated wholly or partly within, or border upon, this state, or are within its jurisdiction, except those private waters that do not combine or effect a junction with natural surface or underground waters.

**3701-29-02 Scope, responsibility for compliance, and applicability of rules.**

- (A) The scope of the rules includes the performance of sewage treatment systems, gray water recycling systems, and persons, agencies, and organizations as these relate to the effective management of these systems throughout the state, including the siting, design, installation, alteration, operation, monitoring, service and maintenance, repair, and abandonment of a STS or GWRS.
- (B) Unless otherwise specified, the rules apply to both HSTS and SFOSTS, referred to jointly as STS, and where applicable, GWRS.
- (C) In accordance with section 3718.012 of the Revised Code, a sewage treatment system that was in operation prior to the effective date of these rules shall not be required to be replaced with a new sewage treatment system, and shall be deemed approved if the system does not cause a public health nuisance, or if the system is causing a public health nuisance as provided in section 3718.011 of the Revised Code, repairs are made to the system that eliminate the public health nuisance as determined by the applicable board of health. Repairs must be completed in accordance with the requirements of this chapter. A board of health may require components, be added or exposed to determine compliance with this chapter. Nothing in this section prohibits the required upgrade of an existing STS when additional flows are being added or when substantial changes to the structure occur. Additionally, nothing in this section exempts a STS from compliance with the requirements specified in paragraph (E) of rule 3701-29-06 of the Administrative Code.
- (D) Chapter 3701-29 of the Administrative Code shall apply to all STS or GWRS installed, altered, or operated after the effective date of this chapter. All STS repairs shall be completed in compliance with this chapter.
- (E) In cases where a board of health has provided written approval for a HSTS design prior to the effective date of this chapter, the board of health shall permit the installation of the system at the applicant's request under the following conditions:
  - (1) There is written documentation that the HSTS design was approved by the board of health and the written approval has not expired.
  - (2) The HSTS shall not conflict with provisions of the NPDES program established in section 6111.03 of the Revised Code or rules adopted or permits issued pursuant to section 6111.03 of the Revised Code.
  - (3) Other than the siting and HSTS specifications previously approved by the board of health, the provisions of this chapter shall apply.
  - (4) The installation permit for the HSTS is issued by the board of health prior to the first day of January 2017.
- (F) For purposes of this chapter, and for the approval or denial of the installation, operation, or alteration of a sewage treatment system under this section, economic impact means all of the following, as applicable:
  - (1) The cost to the property owner for the installation of the proposed sewage treatment system, including the cost of progressive or incremental installation of the system for STS repair or replacements;
  - (2) The cost of an alternative system, including but not limited to the cost of progressive or incremental installation of the system for STS repair or replacements, that when installed and maintained properly, will not create a public health nuisance compared to the proposed sewage treatment system, and is in compliance with this chapter and Chapter 3718. of the Revised Code;

- (3) The costs of repairing the sewage treatment system, including the cost of progressive or incremental repairs, as opposed to replacing the system with a new system; and
  - (4) The annual and long term cost of operation and maintenance of the system.
- (G) In accordance with division (B)(1) of section 3718.02 of the Revised Code, when a board of health proposes to adopt more stringent rules, economic impact must be considered to justify any potential increase in cost of a STS. For the purpose of this rule, economic impact means demonstration by the board of health of one or more of the following:
- (1) The presentation of quantitative data showing an identifiable concern with existing or future STS such that the proposed rule is necessary to mitigate or prevent the occurrence of public health nuisance conditions;
  - (2) The presentation of quantitative data showing that the proposed rule is necessary to meet effluent quality standards for discharging STS that have received coverage under the household general NPDES permit; or
  - (3) That the proposed rule is necessary to achieve a demonstrable change in established water quality standards for the area served by the health district.
- (H) A board of health may regulate the siting, design, installation, operation, monitoring, maintenance and/or abandonment of SFOSTS in accordance with section 3718.021 of the Revised Code. When the rules specifically address SFOSTS, the provisions apply to those SFOSTS that are under the jurisdiction of a board of health having met the following requirements:
- (1) The board of health has determined that all applicable provisions of the rules related to SFOSTS can be fully implemented under its authority.
  - (2) The board of health has sent a letter of notification to the director of health and the director of the Ohio environmental protection agency at least sixty days prior to the date when the board of health will assume authority for SFOSTS. The letter of notification shall include the intended date for transfer of jurisdiction and shall indicate compliance with paragraph (H)(1) of this rule.
- (I) Certain design standards contained in Chapter 3701-29 of the Administrative Code for SFOSTS differ from those standards for on-site systems regulated under Chapter 3745-42 of the Administrative Code due to affirmative maintenance requirements for SFOSTS under this chapter. Differences in design standards between these two chapters of the Administrative Code should not be construed as a conflict of law.
- (J) Unless otherwise specified in this chapter, the persons responsible for compliance with the rules, including but not limited to the siting, design, installation, alteration, operation, monitoring, service and maintenance, repair and/or abandonment of a STS, shall be the owner and/or responsible management entity and/or any person performing a related service or activity, including but not limited to an installer, service provider, septage hauler, soil evaluator, or designer for the work they perform on the system. Enforcement action may be taken against the owner and/or any person who performs a related service or activity.
- (K) The department of health and the board of health are responsible for implementation of this chapter. The department of health shall provide written technical guidance and rule interpretation to the board of health upon request.

**3701-29-03 Registration of installers, service providers, and septage haulers.**

- (A) Except as provided in paragraph (M) of this rule, only persons registered by the board of health as an installer, septage hauler, or service provider shall perform the duties defined in paragraphs (FFF), (JJJJ), or (OOOO) of rule 3701-29-01 of the Administrative Code, respectively.
- (B) Installers, septage haulers, and service providers shall register with the board of health for each category of work prior to performing the duties defined in paragraph (FFF), (JJJJ), or (OOOO) of rule 3701-29-01 of the Administrative Code within the board's jurisdiction. A registration shall not be transferable and shall expire at the end of the calendar year.
- (C) An application for registration as an installer, septage hauler, or service provider shall be made to the board of health and shall include:
- (1) The registration fee established by a board of health in accordance with rule 3701-36-14 of the Administrative Code;
  - (2) Proof of compliance with testing requirements related to the category of registration established by the department of health. If a registration is revoked or suspended in accordance with paragraph (L) of this rule, the board of health may require the registrant to demonstrate compliance with testing requirements before a registration is reinstated or a new registration is issued by the board of health.
  - (3) Proof of compliance with any system specific training, qualification, or certification required as a condition of a system's approval by the director, or one of the following:
    - (a) Provide proof of status as an Ohio waste hauler association qualified service provider, or proof of certification in the national association of wastewater transporters O&M or inspector programs;
    - (b) Other certification programs developed and/or authorized by the director; or
    - (c) Hold a current Class A, I, II, III or IV treatment works operator certification from Ohio EPA as authorized under Chapter 3745-7 of the Administrative Code.
  - (4) Proof of no less than five hundred thousand dollars general liability insurance coverage. In the case of dual or multiple registrations as an installer, septage hauler, and/or service provider, the required general liability insurance shall apply to multiple registration categories.
  - (5) Beginning with the registration year starting on January 1, 2016, proof of completion of at least six continuing education hours during the previous calendar year through educational programs approved by the department of health or demonstration of competency obtained through one of the following mechanisms:
    - (a) Installers may provide proof of status as a certified installer of onsite wastewater treatment systems through the national environmental health association;
    - (b) Septage haulers may provide proof of status as a vacuum truck technician through the national association of wastewater transporters;
    - (c) Service providers may provide proof of status as an Ohio waste hauler association qualified service provider, or proof of certification in the national association of wastewater transporters O&M or inspector programs; or
    - (d) Other continuing education programs as authorized by the director.

Registrants shall provide proof of compliance with this paragraph at the time of registration renewal. In the case of dual or multiple registrations as an installer, septage hauler, and/or service provider, required continuing education hours may apply to multiple registration categories as approved by the department of health.

- (6) Proof of a surety bond or other financial assurance options approved by the director of health which provides statewide coverage for all work performed on a STS in any local health district in the state of Ohio, on a form provided by the director of health.
- (a) The surety bond or financial assurance shall establish a contractual relationship between the principal and the surety or guarantor, and shall be executed by the applicant as principal and a surety company authorized to do business in the state as surety or the guarantor.
- (b) The surety bond or financial assistance shall be for the benefit of any aggrieved party for damages incurred as a result of a violation of this chapter. For purposes of this rule, aggrieved party means system owner or the agent of the system owner where the system owner has contracted with an installer, service provider or septage hauler and whose STS is not installed, altered, serviced, maintained or abandoned in compliance with the provisions of this chapter.
- (c) The surety bond or financial assistance shall be issued to provide insurance coverage for the calendar year of the registration application for any work performed in all local health districts in Ohio. The surety bond shall provide that the aggregate liability of the surety for any and all breaches of the conditions of the bond shall in no event exceed the penal sum of the bond for each calendar year for which the bond is issued. The financial assurance shall provide that the aggregate liability of the financial assurance for any and all breaches of the conditions of the financial assurance shall in no event exceed the penal sum of the financial assurance for each calendar year for which the financial assurance is issued.
- (d) If the surety bond or financial assurance for the registration is canceled, the registrant shall immediately submit to each board of health where a registration has been issued proof of a new surety bond or financial assurance in accordance with the requirements of this rule. The surety company or guarantor of the financial assurance shall give ninety days written notice to the director of health prior to the effective date of cancellation. In the event that a surety bond or financial assurance is canceled and the registrant does not submit proof of a new bond or financial assurance to the board of health, the registration shall be suspended and the registrant shall cease from performing the duties of a registered contractor.
- (e) An installer, service provider, and septage hauler shall maintain a separate surety bond or financial assurance in the amount as required in Table 1 for each category of registration. If an installer also registers as a service provider, then the surety bond for the service provider registration shall be reduced to fifteen thousand dollars.

**Table 1. Contractor bonding requirements.**

Number of systems (annually)	Installer		Service Provider		Septage Hauler	
	HSTS	SFOSTS	HSTS	SFOSTS	HSTS	SFOSTS
One system	Equal to system cost	\$25,000	N/A	\$25,000*	\$25,000	\$25,000
More than one system	\$40,000		\$25,000*		\$25,000	

\* STS service provider bond requirement reduced to \$15,000 for service providers with dual registration as STS installer and STS service provider.

- (f) Any person who alleges to be an aggrieved party shall give written notification to the surety or guarantor of the financial assurance, the board of health where the work was performed, and the installer, service provider, or septage hauler as applicable within eighteen months of the date of completion of the work on the STS. The board of health may conduct an investigation as necessary to determine if a violation of this chapter has occurred.
- (7) Any forms, permits, plans, service records or other documentation for prior system installation, alteration, service or repairs that have not been submitted to the board of health as required.
- (8) Any other information as required by the board of health or department of health.
- (D) A registrant that is a partnership, corporation, or other business association, shall designate one partner, officer, or other responsible full-time employee who shall be the company's representative registrant.
- (E) Registration is not required of any person who performs labor or services as an employee under the direct supervision of a registered contractor. For purposes of this rule "direct supervision" means that a registered contractor instructs and controls the person claimed to be supervised, the person is an employee of the registered contractor, and that the registered contractor is responsible for the actions of that person and is reasonably available if and when needed, even though such registered contractor may not be physically present at the work site.
- (F) Subcontractors who perform work under contract for a registered installer, septage hauler, or service provider for electrical or plumbing work are not required to obtain a registration as a registered installer, septage hauler, or service provider.
- (G) When the registered service provider performs the duties of a service provider on only the registrant's personal residence, the service provider shall be exempt from paragraphs (C)(4), and (C)(6) of this rule and the board of health may waive paragraphs (C)(1) and (C)(5) of this rule, or require continuing education applicable to the product as specified by the manufacturer. A registered service provider that performs the duties of a service provider on only the registrant's personal residence shall be subject to paragraph (J) of this rule.
- (H) When the registered installer performs the duties of an installer on only the registrant's personal residence, the board of health may waive paragraphs (C)(1), (C)(4), and (C)(6) of this rule.
- (I) In addition to the other requirements of this chapter, registered septage haulers shall comply with the following:
  - (1) Registered septage haulers shall obtain a permit from the board of health in accordance with paragraph (B) of this rule for each vehicle used to haul septage within the board's jurisdiction and comply with all applicable septage disposal and land application regulations;
  - (2) Registered septage haulers shall provide a completed application to include the tank capacity of each vehicle to the board of health;
  - (3) Vehicles shall be marked with company name and phone number that is readily legible during daylight hours from a distance of fifty feet while the vehicle is stationary, in accordance with the "Federal Motor Carrier Safety Administration" regulations as described in 49 C.F.R. 390.21(c)(3);
  - (4) All septage hauling equipment shall be maintained in proper operating condition. All tank seal safety specifications shall be met to prevent leakage or spills while in operation, transit, or storage; and
  - (5) When a vehicle is used by the registrant in multiple jurisdictions, the registrant may choose to have the vehicle inspected by the county or combined health district in which the company is based



utilizing an inspection form created by the director and submit the inspection form to other boards of health in lieu of multiple inspections per vehicle.

- (J) Every registrant shall maintain and submit to the board of health such complete and accurate records as may be required for determining compliance with all applicable rules of this chapter.
- (K) Every registrant shall comply with any reporting or records retention requirements established by the board of health and this chapter. Service providers shall provide all O&M records, including sampling results, if applicable, as required under rule 3701-29-19 of the Administrative Code to the board of health. For sewage treatment systems that include a pretreatment component, any service agreement for the pretreatment component shall include the maintenance and monitoring of all system components.
- (L) A registrant shall comply with Chapter 3718. of the Revised Code, restrictions on system approvals by the director of health, all provisions included in a permit issued by the board of health, all board of health orders, and any conditions placed on the contractor's registration.
  - (1) A board of health may inspect installers, service providers or septage haulers during their work to ensure compliance with this chapter.
  - (2) When the board of health finds that a registrant is or has engaged in practices in violation of this chapter, the board of health shall provide the registrant with written notification of the alleged violation, indicate that the registration may be revoked or suspended, and afford an opportunity for a hearing if the registrant does not agree to voluntary compliance.
  - (3) The board of health may deny, revoke or suspend a registration when a registrant fails to timely correct violations in compliance with this chapter, or if the registrant has a history of recurrent violations of this chapter, or has been convicted of violations of this chapter.
  - (4) The board of health shall notify the department of health within sixty days following the suspension or revocation of a registration.
- (M) The owner of a campground licensed in accordance with Chapter 3729. of the Revised Code who engages in the collection and transportation of domestic septage within the premises of the campground shall not be required to register under this rule provided the following conditions are met:
  - (1) The domestic septage is not transported across or on a public roadway;
  - (2) All septage hauling equipment shall be maintained in proper operating condition and designed to prevent spills while in operation, transit or storage; and
  - (3) All septage hauling equipment shall be available for inspection by the board of health.

**3701-29-04 Survey to determine compliance.**

- (A) The director of health shall survey each STS and gray water recycling program of the city and general health districts at least once every three years to determine whether there is substantial compliance with the requirements of Chapter 3718. of the Revised Code pertaining to health districts and the provisions of Chapter 3701-29 of the Administrative Code. The board of health shall provide all requested information to complete the survey.
- (B) The director shall obtain and consider comments from the association of Ohio health commissioners in developing a survey methodology. The survey methodology shall be provided to each board of health and shall include:
- (1) A review of any locally adopted regulations for consistency with this chapter, the administrative aspects of the STS and gray water recycling program including application, site and plan review, permitting and inspections, operational oversight, staff resources and knowledge of the technical aspects of the program, cost analysis and fee adoption, registration of installers, service providers and septage haulers, related reports, sampling, investigations, and enforcement activities;
  - (2) A field review of STS and gray water recycling inspections for siting or installation and during operation to evaluate overall compliance with STS and gray water recycling siting, design, installation, operation, monitoring, maintenance, and abandonment as set forth in this chapter; and
  - (3) Field training and education for board of health program staff.
- (C) The director shall survey the STS and gray water recycling program in accordance with the survey methodology and shall determine whether the board of health is in substantial compliance and qualified to administer and enforce this chapter. After the survey is complete, the director shall propose to classify the health district as either approved, provisional, or disapproved, and shall provide a survey report with recommendations or guidelines to correct program deficiencies and shall provide a survey report to the health district or board. If the director proposes to classify the health district or authority as provisional, the director shall provide:
- (1) A set time frame for correcting the deficiencies;
  - (2) Procedures for program disapproval that the department will pursue if the health district or authority fails to correct the major deficiencies revealed by the survey; and
  - (3) An opportunity to request an informal hearing with a representative of the director to discuss the deficiencies in compliance with paragraph (D) of this rule.
- (D) If the health district or authority wishes to request an informal hearing concerning the director's proposed determination, the district or authority shall submit a written request to the director no later than fifteen days after the date of mailing the proposed determination. The informal hearing shall be conducted before the director or the director's authorized representative no later than thirty days after the director of health received the request for hearing. At the hearing, a representative of the health district or authority may present information orally and in writing. The director shall issue a written decision no later than thirty days after the conclusion of the informal hearing.
- (E) The department shall reevaluate a health district or authority's provisional STS and gray water recycling program in the established time frame to determine if the program is in compliance. If in compliance, the director shall classify the health district or authority as approved. If the deficiencies have not been corrected, the director shall propose to disapprove the health district or authority, or shall propose to revoke the approval, whichever is appropriate.

- (F) The director may reinstate a health district or authority as approved to administer and enforce the STS and gray water recycling program if the health district or authority can demonstrate to the satisfaction of the director an ability to adequately administer and enforce the provisions of this chapter.
- (G) Upon determining that a health district or authority is so qualified, the director shall approve the district or authority and place such district or authority on an approved list. The director may resurvey any approved district or authority when, in his opinion, such resurvey is necessary and remove from such approved list any district or authority found not to be adequately carrying out the provisions of this chapter.
- (H) If after a survey as provided for in this rule, the director determines that a health district or authority is not qualified to carry out the provisions of this chapter, he shall certify that fact to the board of health and disapprove the health district or authority to administer and enforce the STS and gray water recycling program. If a health district or authority is not eligible to be placed on the approved list, the director may designate another qualified health district or authority as the department in such health district or shall administer and enforce this chapter in such health district.
- (I) If a health district is removed from the approved list, the board of health shall pay to the director or to the board of health designated by the director to serve as the department in such health districts, all fees previously paid to the board under this chapter in the previous twelve months that have not been expended or encumbered. All fees paid to the director or to the designated board of health shall be used as specified in rule 3701-29-05 of the Administrative Code.

**3701-29-05 Fees and fee categories.**

- (A) Boards of health of city or general health districts shall establish fees in accordance with section 3709.09 of the Revised Code for the purpose of administering and enforcing the requirements of this chapter. The fees shall be established using the categories prescribed in paragraph (D) of this rule and the cost methodology prescribed by rule 3701-36-14 of the Administrative Code.
- (B) All fees collected by the board of health under this chapter shall be deposited in a special fund of the health district to be used exclusively by the board of health to pay the cost of administering and enforcing this chapter as provided in division (A)(1) of section 3718.06 of the Revised Code.
- (C) A portion of each permit fee for the installation of a new or replacement HSTS, SFOSTS, or GWRS and/or for the alteration of an existing HSTS, SFOSTS, or GWRS shall be collected by a board of health and shall be transmitted to the director for deposit into the general operations fund created pursuant to section 3701.83 of the Revised Code to pay the costs of administering and enforcing this chapter and Chapter 3718. of the Revised Code as provided in division (A)(2) of section 3718.06 of the Revised Code. A board of health shall collect this fee at the same time that it collects the fee established under paragraph (A) of this rule and as set forth below:
- (1) Upon the effective date of this rule, twenty-five dollars of each permit fee for the installation of a new or replacement HSTS, SFOSTS, or Type 2, 3 or 4 GWRS and fifteen dollars of each fee for the alteration of an existing HSTS, SFOSTS, or Type 2, 3 or 4 GWRS collected by a board of health shall be transmitted by the board of health to the director for deposit into the general operations fund.
  - (2) Beginning January 1, 2016, fifty dollars of each permit fee for the installation of a new or replacement HSTS, SFOSTS, or Type 2, 3 or 4 GWRS and twenty-five dollars of each fee for the alteration of an existing HSTS, SFOSTS, or Type 2, 3 or 4 GWRS collected by a board of health shall be transmitted by the board of health to the director for deposit into the general operations fund.
  - (3) Beginning January 1, 2017, seventy-four dollars of each permit fee for the installation of a new or replacement HSTS, SFOSTS, or Type 2, 3 or 4 GWRS and thirty-five dollars of each fee for the alteration of an existing HSTS, SFOSTS or Type 2, 3 or 4 GWRS collected by a board of health shall be transmitted by the board of health to the director for deposit into the general operations fund.
- (D) Boards of health shall establish fees in accordance with section 3709.09 of the Revised Code when any of the following services or functions are provided:
- (1) An application for a site review of an HSTS, SFOSTS or GWRS.
  - (2) An application for a soil evaluation for an HSTS, SFOSTS or GWRS.
  - (3) An application for a design for an HSTS, SFOSTS or GWRS.
  - (4) Permit for the installation of a new or replacement HSTS and GWRS.
  - (5) Permit for the alteration of an existing HSTS and GWRS.
  - (6) Permit for the installation of a new or replacement SFOSTS.
  - (7) Permit for the alteration of an existing SFOSTS.

- (8) Permit for the operation of an HSTS and SFOSTS, which may vary based on the length the permit is valid and/or complexity of the system.
  - (9) Registration of installers, service providers and septage haulers, which may vary based on category of registration.
  - (10) Vehicle permits for septage haulers.
  - (11) Inspection of a GWRS or a STS as authorized in division (A)(7) of section 3718.02 of the Revised Code or for re-inspection to ensure compliance with this chapter as allowed in rule 3701-29-09 of the Administrative Code.
  - (12) Abandonment of a STS or GWRS.
  - (13) Application for a variance.
  - (14) Collection and examination of effluent samples taken to determine compliance with this chapter.
  - (15) A site review, evaluation and approval/disapproval of land application of septage.
  - (16) Review of a subdivision or lots in accordance with rule 3701-29-08 of the Administrative Code.
  - (17) Additional fees may be established by the board of health of a city or general health district pursuant to section 3709.09 of the Revised Code for the purposes of managing the STS program.
- (E) When the board of health determines that the installation of a new or replacement STS or GWRS or the alteration of an existing STS or GWRS has commenced prior to a permit being issued or a person performs the duties of an installer, septage hauler, or service provider prior to obtaining registration or a vehicle permit as required in rule 3701-29-03 of the Administrative Code, a board of health shall specify an amount to be added to the applicable fees established in this rule in accordance with section 3709.09 of the Revised Code.
- (F) A board of health of a city or general health district shall certify the amount collected under division (A)(2) of section 3718.06 of the Revised Code and paragraph (C) of this rule and transmit this amount to the treasurer of the state on forms approved by the director of health according to the schedule outlined in section 3709.092 of the Revised Code.

**3701-29-06 General provisions and prohibitions.**

- (A) The siting, design, installation, alteration, operation, monitoring, maintenance, repair, and abandonment of a STS or GWRS shall comply with this chapter.
- (B) A STS or GWRS, as applicable, shall not be installed, altered, or operated without an approved permit from the board of health.
  - (1) A board of health shall not permit or otherwise authorize the use of a STS or GWRS that would violate the conditions of these rules or is not in compliance with paragraph (C) of rule 3701-29-02 of the Administrative Code
  - (2) The STS or GWRS owner is responsible for ensuring that a STS or GWRS is maintained in proper working condition.
  - (3) The STS or GWRS owner shall comply with the conditions specified in an installation, alteration, and/or operation permit issued by the board of health, including, but not limited to requirements for securing a service contract and other maintenance requirements.
- (C) All sewage and human excreta generated from within a dwelling or building shall be conveyed to an approved STS or a sanitary sewerage system. All or a portion of the gray water from the dwelling or building may be conveyed to an approved GWRS installed and operated in accordance with rule 3701-29-17 of the Administrative Code.
- (D) A HSTS shall serve only a one family, two-family, or three-family dwelling. A SFOSTS may serve multiple dwellings or structures. In the case where two or more dwellings or structures are served by a SFOSTS, the entire SFOSTS shall be owned and operated by one person.
- (E) A STS or GWRS shall comply with the following performance requirements and prohibitions:
  - (1) Shall be maintained in proper working condition.
  - (2) Shall comply with the conditions specified in an installation and/or operation permit issued by the board of health.
  - (3) No STS or GWRS or part thereof shall create a public health nuisance, as defined in section 3718.011 of the Revised Code, or safety hazard. No STS or GWRS or part thereof shall cause an exceedance of water quality standards for surface water or drinking water.
  - (4) No STS or GWRS permitted for installation, replacement, or update on or after January 1, 2007 shall discharge to any ditch, stream, pond, lake, natural or artificial waterway, drain tile, other surface water conveyance or to the surface of the ground unless authorized by an NPDES discharge permit pursuant to Chapter 6111. of the Revised Code or otherwise specified in this chapter.
  - (5) No sewage or effluent shall be discharged to an abandoned well, drainage well, a dry well or cesspool, a sink hole or other connection to ground water. If classified as a class V injection well, a HSTS serving a two or three family dwelling or a SFOSTS shall comply with 40 C.F.R. 144 (as published in the July 1, 2005 Code of Federal Regulations) and the UIC registration requirements pursuant to Chapter 3745-34 of the Administrative Code. Existing GWRS that use dry wells in a campground licensed in accordance with Chapter 3729. of the Revised Code are authorized for use until such system fails or creates a public health nuisance as defined in paragraph (C) of rule 3701-29-17 of the Administrative Code.

- (6) No STS or GWRS shall receive water from roof, foundation, clear water sumps, swimming pools, or other sources that do not convey or generate sewage from the structures served by the STS. An appropriately sized STS may receive brine discharge from a water softener unless otherwise prohibited by a manufacturer through the product specific approval by the director of health, a permit issued by the board of health, or as required to repair a failing system.
  - (7) No STS shall be permitted for the holding, treatment, or dispersal of industrial waste or storm water for industrial activities. For the purpose of this rule, the normal use of housekeeping products does not constitute industrial waste.
  - (8) The owner of an existing, discharging HSTS shall obtain coverage under the Ohio EPA household general NPDES permit prior to any replacement or update of the system as defined under paragraph (I) of rule 3701-29-01 of the Administrative Code.
- (F) A STS shall use soil absorption as the means for final treatment and/or dispersal, except for HSTS when the soil absorption component cannot meet the requirements of this chapter and the following conditions and limitations are met:
- (1) Soil absorption is required for all STS permitted for use in any new lot or new subdivision created after January 1, 2007.
  - (2) When soil absorption for a system is not feasible in accordance with this chapter for a replacement HSTS for an existing dwelling or a new HSTS for an existing lot, a discharging HSTS shall only be permitted by the board of health in compliance with NPDES requirements.
  - (3) New or existing soil absorption components may be used to receive a portion of the effluent from a discharging HSTS that has received coverage under the Ohio EPA household general NPDES permit provided the quality of the discharged effluent is maintained and the HSTS design does not compromise director of health approvals in compliance with rule 3701-29-13 of the Administrative Code.
- (G) STS shall be sited in compliance with this chapter including the following:
- (1) Soil absorption replacement areas shall meet the following requirements:
    - (a) Except when designing a replacement STS for an existing dwelling on an existing lot, sufficient suitable area shall be available to accommodate a STS including a designated area for complete relocation and replacement of a STS. The minimum horizontal isolation distances as required in paragraph (G)(3) of this rule, and any additional horizontal isolation distance determined by the board of health as necessary to accommodate lateral flow due to shallow limiting conditions identified in the soil evaluation conducted in accordance with rule 3701-29-07 of the Administrative Code shall be met for the STS and designated replacement area.
    - (b) If a reduction is used during the design of a STS, the owner shall ensure that any area for system expansion of the original STS is protected. If possible, replacement areas should be designed utilizing the full daily design flow, not a reduced system.
    - (c) The replacement area shall be identified during design. The replacement area shall be set aside and protected during the construction process and from additional development and/or damage by the owner.
    - (d) An owner may request a reevaluation of the size or location of the replacement area from the local health department if new technologies become available that provide a smaller soil absorption area if the owner proposes another use of the designated replacement area.

- (e) Boards of health shall not waive the requirement for sufficient area to accommodate for complete relocation and replacement of a STS when reviewing the creation of new lots and subdivisions in accordance with rule 3701-29-08 of the Administrative Code.
- (2) Sites on which private water systems are to be installed shall be of sufficient area to provide horizontal isolation of the private water system from both the proposed STS and the area intended for any STS relocation or replacement on this or adjacent sites as required in paragraph (G)(3) of this rule.
  - (3) A STS shall maintain the following minimum horizontal isolation distances:
    - (a) All components of a STS shall be at least ten feet from any utility service line, roadway or road surface, driveway or other hardscape, property line or right-of-way boundary, properly sealed well, any building or other structure, areas with recorded easements, intermittent streams, swales, geothermal horizontal closed loop systems, irrigation lines and GWRS.
    - (b) A STS soil absorption component shall be at least fifty feet from any surface water impoundment, lake, river, wetland, perennial stream, and road cut-banks or stream cut-banks.
    - (c) All components of a STS shall be at least fifty feet from any water supply source and vertical open and closed loop geothermal heating and/or cooling system.
    - (d) Sewers and wastewater drains outside of the foundation of a building shall be located a minimum of ten feet from a water supply source or water distribution line when attainable except within five feet of the foundation where both lines enter a building and in circumstances when the water line and sewer line must cross. When a sewer line crosses a water service line, the following applies:
      - (i) Provide a minimum vertical distance of twelve inches between the outside of the water service line and outside of the sewer. This shall be the case where the water line is either above or below the sewer with preference to the water line located above the sewer.
      - (ii) At crossings, one full length of water pipe shall be located so both joints will be a minimum of ten feet from the sewer line and a twenty-foot section larger diameter pipe sleeve shall be installed on either the water service line or the sewer line and the pipe sleeve sealed at both ends. A water service line and sewer line shall not share the same trench except where they must cross.
    - (e) Watertight non-treatment devices or components for replacement systems may be installed within the required horizontal isolation distance provided they will not directly affect surface or subsurface water sources or other structures.
    - (f) Any more stringent horizontal isolation distance included as a condition of an approval by the director of health or defined in these rules for specific STS or treatment components.
  - (4) Except when the repair or replacement of the STS cannot be sited on the same parcel, a sewage treatment system shall be sited on the same parcel as the structures or dwelling served by the STS. The following conditions shall apply to any STS repair or replacement not sited on the same parcel:
    - (a) A permanent, recorded, legal easement shall be required for any portion of a STS, including the discharge line(s) from the system or associated drains, not sited on the same parcel as the structures or dwelling served by the STS. When an easement is required under this paragraph, a STS installation permit shall not be issued by the board of health until a certified copy of the legally recorded easement is provided.



- (b) When a portion of a STS is sited on a parcel other than the parcel containing the structure(s) or dwelling(s) served by the STS and both parcels have a common owner, the parcels shall either be merged or otherwise reconfigured, or recorded on the property deed.
- (c) An easement or merger of parcels shall no longer be required when the STS is abandoned in accordance with rule 3701-29-21 of the Administrative Code and the required dwelling(s) or structure(s) are connected to a public sewer.

(H) STS shall not be sited under the following conditions:

- (1) A new STS shall not be sited in an area identified as a flood way, and only below grade soil absorption components of a new STS may be sited within any part of the one hundred-year flood plain except where prohibited by federal, state, or local regulations or ordinances.
  - (2) A STS shall not be sited within a jurisdictional wetland subject to a U.S. army corps of engineers 404 permit and/or Ohio EPA 401 certification or within an isolated wetlands subject to sections 6111.02 to 6111.028 of the Revised Code.
  - (3) A STS shall not be sited within the sanitary isolation radius of a public water system well as determined in accordance with rule 3745-09-04 of the Administrative Code. A SFOSTS shall have additional design and/or O&M requirements when sited within the inner management zone of a drinking water source protection area determined to be highly susceptible to contamination by the Ohio EPA source water assessment and protection program for a community or non-transient non-community public water system as defined in rule 3745-81-01 of the Administrative Code.
  - (4) A STS shall not be sited in soil and site conditions that prohibit compliance with this chapter.
- (I) A STS shall not be sited, permitted, or installed where a sanitary sewerage system is accessible, unless otherwise excepted by law. Whenever a sanitary sewerage system becomes accessible to a dwelling or structure served by a STS, the dwelling and/or structures shall be connected to the sanitary sewerage system and the STS abandoned in accordance with rule 3701-29-21 of the Administrative Code.
- (1) In determining the accessibility of a sanitary sewerage system a board of health may consider the availability of connection, local or state ordinances or rules prohibiting or requiring connection, the technical feasibility of connection, the ability of the sanitary sewerage system and associated treatment facility to accept additional flows, and the distance from the foundation wall of the structure from which sewage originates to the nearest boundary of the right-of-way within which the sewer is located.
  - (2) The board of health shall consult with appropriate sewer entity personnel as necessary to determine sanitary sewerage accessibility.
- (J) The conditions and schedule for connection to a sanitary sewer which may be established by the board of health shall not conflict with findings and orders by the Ohio EPA or orders from the county commissioners or other local authority.

**3701-29-07 Soil evaluation and soil evaluators.**

- (A) Soil evaluators shall have the knowledge and experience to facilitate the review of site and soil conditions, information provided by the homeowner, and these rules to identify appropriate areas for the siting of STS or GWRS. Soil evaluators shall be knowledgeable of the requirements of this chapter, available STS technologies, and the science of pedology. Soil evaluations shall be completed by:
- (1) A soil scientist or soil classifier certified by the soil science society of America (SSSA) completing the soil evaluation while acting as an independent agent of the owner or board of health;
  - (2) A SSSA associated professional soil scientist that is supervised by a SSSA certified soil scientist completing the soil evaluation while acting as an independent agent of the owner or board of health;
  - (3) A soil professional registered by a state or national organization with equivalent minimum qualifications and/or demonstration of competency for soil evaluation as approved by the director of health;
  - (4) A registered sanitarian employed by the board of health having jurisdiction where the soil evaluation is to take place completing the soil evaluation on behalf of the board of health when the employee is determined by the board of health to be capable of meeting the tasks in paragraph (C) of this rule; or
  - (5) Other persons approved under a certification program or other training program as approved by the director of health.
- (B) Any board of health that completes soil evaluations in compliance with paragraph (A) of this rule may adopt a fee for the cost associated with performing the soil evaluation provided the fee is in compliance with rule 3701-36-14 of the Administrative Code. Nothing shall prevent an owner from securing a soil evaluation from an independent agent in compliance with paragraph (A) of this rule in lieu of a soil evaluation completed by the board of health and the associated fee.
- (C) For the purposes of this chapter, soil evaluators shall perform the following tasks required for soil evaluations through submission of complete and accurate soil evaluations:
- (1) Describe all limiting conditions within the soil depth investigated as defined in paragraph (III) of rule 3701-29-01 of the Administrative Code;
  - (2) Use the NRCS field book for describing and sampling soils to describe:
    - (a) Munsell color table to accurately describe soil color (hue, value, and chroma) and redoximorphic features (concentrations and depletions) to accurately estimate depth to saturated soil;
    - (b) Describe soil horizons and the depth of each horizon;
    - (c) Describe the soil texture of each horizon (class, percentage clay, percentage rock fragments);
    - (d) Describe the structure of each soil horizon (grade, size and shape of structural units);
    - (e) Describe the moist consistence of the soil for each horizon;
    - (f) Describe the slope and surface contours as applicable to STS or GWRS designs;
  - (3) Describe and document the extent of the suitable soil; and

- (4) Have sufficient knowledge of this chapter.
- (D) The soil evaluator shall visit the site where the STS or GWRS is to be located during the soil evaluation to observe the site conditions and observe and document the soil profile at a sufficient number of locations as determined by the board of health and the soil scientist to accurately reflect the variation in soil and site conditions across the proposed sewage treatment system soil absorption areas, by the use of soil borings and/or excavations of sufficient depth to determine the presence of all limiting conditions but no greater than sixty inches.
- (1) The soil evaluator shall document the soil profile using a form prescribed by the department of health for the most representative soil borings and/or excavations and identify the area for which each soil boring and/or excavation is representative.
  - (2) The location of described soil borings and/or excavations and the representative area for each soil boring and/or excavation shall be staked or flagged on site by the soil evaluator. Staking of representative areas may not be required when they can be identified using natural or in-place markers.
  - (3) Documentation submitted to the board of health shall be legible and contain sufficient detail to demonstrate compliance with the provisions of this chapter.
- (E) At a minimum the soil evaluation shall include:
- (1) A site drawing. The site drawing shall be scaled or include sufficient dimensions to identify locations of all soil borings and/or excavations, locations of the representative area for described soil borings and/or excavations and applicable site features as determined by the board of health. The evaluator may use previously prepared or otherwise available drawings such as a survey prepared by a registered professional surveyor, an aerial photograph or digital orthophotograph prepared from a geographical information system, or other similar drawing. The drawing shall include the assessment and documentation of the following:
    - (a) Any existing dwellings and/or structures and any proposed dwellings and/or structures, if known;
    - (b) Any site disturbances such as excavated or fill areas, existing driveways and other hardscapes and proposed hardscapes, or related site disturbances, if known;
    - (c) Location of all private water systems, abandoned wells, or geothermal systems if known, and surface water features on the lot and within fifty feet of the areas identified for possible system installation;
    - (d) North orientation arrow;
    - (e) Identification of all soil borings and/or excavations;
    - (f) Identification and dimensions of spatial areas for which each soil profile description is representative and where the soil has capacity for the treatment and/or dispersal of effluent. The soil evaluation shall include the entire lot or sufficient area to support a primary system and replacement area on the site;
    - (g) Identification of areas with conditions that would prohibit or impact the siting of a STS or GWRS in accordance with this chapter including, but not limited to: sinkholes, wetland vegetation, bedrock outcrops, areas with a slope greater than twenty five per cent, soils prone to slippage on slopes greater than six per cent, and existing or abandoned drainage tiles, if known; and

- (h) Identification of known or observed easements and right-of-ways.
- (2) Record of the site and soil characteristics for each soil boring and/or excavation location designated in this paragraph using the nomenclature from the NRCS field book for describing and sampling soils on a form prescribed by the director of health, including but not limited to:
- (a) Site descriptions, including but not limited to, landscape position, slope, vegetation, drainage features, rock outcrops, erosion and other natural features;
  - (b) Detailed soil profile descriptions, including but not limited to, color, texture, grade, shape, structure, consistence, and the depth of each soil horizon or layer including fill or mine spoils where present;
  - (c) The identification of limiting conditions as defined in paragraph (III) of rule 3701-29-01 of the Administrative Code;
  - (d) If evident or visible, provide documentation of any relevant surface hydrology, geologic and hydrogeologic risk factors such as bedrock outcrops, sinkholes or karst features on the specific site or in the surrounding area that may indicate vulnerability for surface water and ground water contamination; and
  - (e) Provide documentation of any geologic risk factors affecting the soil's ability to treat and/or disperse effluent including dense tills and fragipan.

**3701-29-08 Subdivisions and new lots.**

- (A) The board of health review required in paragraph (C) of this rule shall be coordinated, as applicable, with authorities having responsibility for the requirements established in Chapter 711. of the Revised Code, zoning, recording of parcels of land, or other land use authorities. The board of health shall consult with appropriate sewer entity personnel such as a municipal or county sanitary engineer to confirm sewer accessibility as described in paragraph (I) of rule 3701-29-06 of the Administrative Code, and plans for sewer extensions by a municipality, sanitary district, regional water and sewer district, or other management entity or wastewater planning authority responsible for sanitary sewerage.
- (B) Any person proposing a subdivision or new lot(s) for review by the board of health shall submit an application and sufficient information to determine compliance with the requirements of this chapter. Minimum information to be submitted or completed for review shall include the following:
- (1) Completed application and any associated fees;
  - (2) Staked or marked locations of proposed lot corners/property lines on site;
  - (3) A scaled drawing. Any person proposing a subdivision may use previously prepared or otherwise available drawings such as a survey prepared by a registered professional surveyor, an aerial photograph or digital orthophotograph prepared from a geographical information system, a soil evaluation or other similar drawing for preliminary review. The drawing shall include the assessment and documentation of the following:
    - (a) The acreage of each proposed lot and the total land area of the proposed subdivision;
    - (b) Proposed lot lines with detail on site conditions including vegetation, and drainage features;
    - (c) Any site information deemed necessary by the board of health related to prior or existing land use including existing and proposed: easements, utilities, structures, wells, foundations, roads, drainage features, water bodies;
    - (d) Identification of one or more system type(s) that might be feasible on the proposed lots in accordance with this chapter; and
    - (e) For new lot or subdivision proposals having more than five lots, or for a fewer number when required by the board of health, the scaled drawing shall also include topographic detail with contour lines sufficient to determine slope and adequate length along the contour in the areas considered suitable for STS.
  - (4) A soil evaluation completed in accordance with rule 3701-29-07 of the Administrative Code for each proposed lot;
  - (5) If required or accepted by the board of health, an order one soil survey of sufficient detail to provide the soil profile information required in paragraphs (D) and (E) of rule 3701-29-07 of the Administrative Code. The preparation of an order one soil survey does not eliminate the need to conduct site specific soil evaluations for individual lots in paragraph (B)(4) of this rule in the subdivision during the system permitting process; and
  - (6) When a proposed subdivision includes the creation of at least twenty-five lots, or for any fewer numbers of lots as required by the board of health, the request shall include written consultation from Ohio EPA concerning the subdivision's accessibility to existing sanitary sewerage systems as described in paragraph (I) of rule 3701-29-06 of the Administrative Code, and risks to surface and ground water resources.

- (7) When subdivisions are proposed within the boundaries of an inner management zone of a public water system, or located within a hydrogeologically sensitive area as delineated on a ground water pollution potential map from the Ohio department of natural resources, the application shall include the map or inner management zone information and how the proposed density and design of the STS shall ensure adequate treatment of effluent prior to discharge to groundwater.
- (C) Proposed subdivisions and new lots shall be reviewed by the board of health to determine compliance with this chapter, including, but not limited to the following:
- (1) For subdivisions proposed within inner management zones of public water systems or areas with high ground water pollution potential, the board of health may require, but is not limited to, alternative STS designs, increased O&M frequencies, a responsible management entity and/or establish a household sewage treatment district in accordance with paragraph (F) of rule 3701-29-19 of the Administrative Code.
  - (2) No lot shall be created which requires a NPDES permit for a discharging STS. All created lots shall meet the requirements of rule 3701-29-06 of the Administrative Code.
  - (3) All proposed STS will meet soil absorption sizing requirements in rule 3701-29-15 of the Administrative Code.
- (D) When a board of health determines that the provisions of this chapter cannot be met or the submitted information is found to be incomplete or inaccurate, the board of health shall provide written documentation of noncompliance to the person proposing a subdivision or new lot(s).
- (E) When the board of health determines that the provisions of this chapter can be met, the board of health shall provide written documentation of compliance to the person proposing a subdivision or new lot(s) subject to STS installation permit approval by the board of health. The written documentation of compliance with this chapter and the board of health review required by this rule shall not preclude the denial of an installation permit pursuant to rule 3701-29-09 of the Administrative Code if conditions change.
- (F) Upon receiving preliminary approval, a survey prepared by a registered professional surveyor shall be required prior to final approval of the subdivision.

**3701-29-09 Site review and permits for STS installation and operation**

- (A) Prior to accepting an application for a permit to install a new or replacement STS or alter an existing STS, the board of health shall require a site review.
- (1) A site review shall include:
    - (a) The completed application and associated fee(s);
    - (b) A soil evaluation completed in accordance with rule 3701-29-07 of the Administrative Code. The board of health may waive the requirement for a soil evaluation based on small lot size, for an alteration, or for an incremental repair plan;
    - (c) A STS design completed in accordance with rule 3701-29-10 of the Administrative Code; and
    - (d) When the applicant is requesting approval of a system subject to paragraph (C) of this rule, an incremental replacement plan shall be submitted with the site review request.
  - (2) The board of health shall review the application information and conduct an on-site evaluation to determine whether the proposed STS design is in compliance with this chapter. When the board of health determines that a proposed STS is subject to the NPDES or UIC requirements of rule 3701-29-06 of the Administrative Code, the board of health shall determine compliance with NPDES or UIC requirements prior to issuing a permit in accordance with paragraph (B) of this rule.
  - (3) The board of health shall disapprove a site review application if:
    - (a) The application information, soil evaluation, STS design, or site review by the board of health indicates that the provisions of this chapter cannot be met;
    - (b) The STS design, soil evaluation, or application information is incomplete, inaccurate or not in compliance with this chapter;
    - (c) The site conditions observed during the site review are such that the provisions of this chapter cannot be met; or
    - (d) The incremental replacement plan is not acceptable to the board of health, if applicable.
  - (4) The board of health shall approve a site review application when the submitted information and site visit by the board of health demonstrate that the provisions of this chapter can be met. A site review approved after the effective date of these rules shall be valid for five years from the date of approval provided there are no changes to the site conditions or the STS design, including the sewage source.
- (B) No person shall install a new or replacement STS or alter an existing STS without an installation or alteration permit issued by the board of health.
- (1) A permit shall include:
    - (a) The completed application and associated fee;
    - (b) An approved site review completed in accordance with paragraph (A) of this rule; and
    - (c) Proof of registration with the Ohio EPA Class V injection well program, if applicable.

- (2) The owner of the STS and/or an authorized agent shall be responsible for all coordination between the local health district, designer, soil evaluator, installer, and Ohio EPA, if applicable.
  - (3) When considering an application for a permit to install a new or replacement STS or alter an existing STS, the board of health shall review the site review, proposed design, and the site conditions at the location where the system is to be installed.
  - (4) The board of health may deny the approval of an installation or alteration permit if there are changes that affect the siting and design of the STS or the site review application information and may require re-application including a fee to reapply.
  - (5) The board of health shall approve the application for the installation of a new or replacement STS or the alteration of an existing STS when the site conditions are consistent with a site review approved by the board of health. The board of health may specify permit terms and conditions governing the siting, design, installation, alteration, operation, monitoring, maintenance, or abandonment of the STS, unless such terms and conditions conflict with Chapter 3718. of the Revised Code or this chapter.
  - (6) An approved installation permit or alteration permit issued by the board of health shall be valid for one year from the date of issuance. The board of health may extend the permit period for an additional six months for permits issued pursuant to this rule. Permits issued by the board of health are transferable upon the sale of the property for which the permit is issued.
  - (7) An approved installation or alteration permit may be revoked by the board of health prior to its expiration if a change in site conditions, the quality of the installation or alteration work, or if other conditions arise that are not in compliance with this chapter.
- (C) The board of health may work with a system owner to develop a plan for incremental repair and/or replacement of a STS when the STS is creating a nuisance condition and/or failing. An incremental repair and/or replacement plan shall be used to establish a phased approach to either repair, alter or replace a STS over a period of time as specified in the plan and as approved by the board of health. When a STS is creating a public health nuisance, an incremental repair and replacement plan shall require sufficient repairs and/or alterations to the STS to minimize or correct the nuisance conditions or system failure in a timely manner. The following shall also apply to incremental repair and replacement of a STS:
- (1) An alteration permit, as applicable, shall be required for each phase of work to be completed on a STS as required in this rule and any prior permit issued for work on the STS has already expired. Permits issued by the board of health as part of an incremental replacement plan are transferable upon the sale of the property for which the permit is issued.
  - (2) The board of health may include conditions in an incremental replacement plan, including but not limited to:
    - (a) The period of time over which the incremental repair and/or replacement will occur, and the established timeframes for addition or replacement of components or other agreed upon steps in the plan;
    - (b) Requirement of a soil evaluation that meets the requirements of rule 3701-29-07 of the Administrative Code;
    - (c) An evaluation of water usage to determine options for reducing the hydraulic load to the STS including, but not limited to the installation of reduced water use fixtures, or voluntary reductions in water usage during phases of the plan;



- (d) An evaluation of waste strength, if applicable, to determine the need for additional pretreatment prior to dispersal to the soil;
  - (e) Phased installation of STS components or devices that include, but are not limited to providing pretreatment of effluent, improving dispersal of effluent to the soil absorption component, adding capacity to the soil absorption component, replacing the soil absorption component or otherwise reducing public health nuisance conditions or system failure; and
  - (f) Annual or periodic inspections. The board of health may require payment of inspection fees for additional inspections required as a condition of a permit that includes an incremental replacement plan.
- (D) The installation of a new or replacement STS or the alteration of an existing STS shall only be conducted by a registered installer under an installation or alteration permit issued by the board of health.
- (1) The installation or alteration shall comply with the approved site review, any conditions of the installation or alteration permit, any conditions of a product approval, the design, and this chapter.
  - (2) Prior to beginning construction of the STS the installer and owner or authorized agent shall review all information on the site review, STS design, and soil evaluation and consult with the appropriate entities concerning questions regarding STS location and construction. If changes to the permitted system design are necessary, the owner or authorized agent and installer shall consult with the board of health and designer before proceeding with the system installation. A new design may be required in such cases.
  - (3) If any disturbance or damage has occurred to the soil absorption area, installation shall not proceed and the installer and owner or authorized agent shall contact the board of health. The board of health shall either approve or deny any proposed modifications to the approved design based on the disturbance or damage that has occurred.
- (E) The board of health shall inspect the installation of the system in a timely manner to reduce the potential damage that can occur from leaving the system open without final cover. Additional inspections during the progress of the installation may be required as a condition of the installation permit, a product approval, or this chapter. The board of health may require advance notification from the installer to accommodate inspections. The construction drawing, any applicable system start-up information, or other required or necessary documentation shall be available at the time of inspection. Evidence of the system approval shall be provided to the installer and owner.
- (F) A drawing(s) of the completed system installation shall be provided by the registered installer for a completed STS installation or alteration. The drawing(s) shall be legible and signed by the installer indicating that the STS was installed in accordance with these rules and shall include a record on eight and a half inch by eleven inch or larger pages with copies provided to the owner and the board of health for inclusion in the permit file. Use of the STS design with construction notes and measurements may be acceptable. The drawing(s) shall also include the following items, as applicable:
- (1) Any changes to the approved STS design including, but not limited to, distances from installed STS components to any items having applicable horizontal isolation distances. A change in location of a STS from that designated on the STS design shall not be made without prior approval by the board of health and shall not violate horizontal isolation distances required by this chapter.
  - (2) A designated vertical reference point or benchmark with its location marked at the site.
  - (3) Plan view drawing for installed STS components per the STS design, including identification of specific products that were installed as part of the STS.

- (4) Any additional information for components and materials may be required by the board of health including but not limited to manufacturer or supplier provision of component installation or O&M instructions and verification of compliance with any start-up procedures or aggregate specifications.
- (G) The board of health shall approve the installation of the system if all conditions of the permit, product approval, STS design and this chapter are met. The board of health may provide a partial approval of the installation when additional work and an additional inspection are necessary to ensure compliance with the permit, product approval, STS design, and/or this chapter. The board of health may require payment of the inspection fee(s) for additional inspection(s) for installations that are partially approved until the installation is approved or the installation permit expires. The board of health may allow for an inspection after the permit has expired, and may change the status of the permit to approved or disapproved upon completion of the inspection.
- (H) The board of health shall inspect the completed system again not later than twelve months after the approval of the installation to observe the system's operation.
  - (1) The board of health shall make an assessment to determine if the system is operating properly and not causing a public health nuisance or safety hazard.
  - (2) The board of health shall certify to the director not later than sixty days after the inspection, that the inspection was performed.
- (I) No person shall operate a STS or a type 2, 3 or 4 GWRS without an approved and valid operation permit from the board of health. The owner, and/or a responsible management entity when applicable, shall comply with the terms and condition of the permit.
  - (1) Any person requesting renewal of an operation permit shall submit:
    - (a) The application fee;
    - (b) Any applicable application form if required by the board of health; and
    - (c) Proof of compliance with any permit conditions.
  - (2) The board of health shall specify any terms and conditions of the operation permit consistent with this chapter governing the operation, monitoring, maintenance, and abandonment of the STS including:
    - (a) Maintenance, operation, and monitoring requirements, including frequency of maintenance;
    - (b) Required effluent quality standards, as applicable; and
    - (c) Requirements for a service contract. An operation permit shall require a service contract for a STS under the following conditions and as otherwise required by the board of health:
      - (i) Any HSTS subject to a NPDES permit; or
      - (ii) When required as a condition of a STS component or system approval granted by the director of health.
  - (3) An operation permit shall be in effect upon board of health approval of an installation, a replacement, or an alteration of a STS.

- (4) An operation permit shall expire at the frequency determined by the board of health, not to exceed ten years.
  - (5) An operation permit may be renewed, suspended, or revoked by the board of health subject to the requirements of this chapter and the terms and conditions of the permit.
- (J) The board of health, not later than sixty days after the issuance of an installation, operation, or alteration permit, shall notify the director that the permit was issued utilizing an electronic system developed by the director. In the absence of an electronic system to collect this information, submission of the fee transmittal forms required in rule 3701-29-05 of the Administrative Code shall satisfy this requirement for notification.
- (K) The board of health shall retain all received records on the installation, alteration, or abandonment of a STS until the STS is permanently abandoned. Operation, maintenance and sampling records generated by the jurisdiction shall be maintained for a minimum of seven years. Records may be maintained in paper or electronic form.

**3701-29-10 STS Designers and Designs**

- (A) STS designs shall be prepared and submitted by persons capable of reviewing the soil evaluation, site conditions, information provided by the homeowner, and these rules to facilitate the choice of an appropriate, site specific STS and complete the STS design in compliance with paragraph (B) of this rule. Designers shall be knowledgeable of the requirements of this chapter and obtain education as necessary or required by manufacturer for all STS technologies they intend to design. Designers may complete the STS design while acting either as an agent of a board of health, or as an independent agent of the homeowner. Any board of health that employs staff qualified to prepare STS designs and offers this service may adopt a fee for the preparation of the design and all associated costs, provided the fee complies with the cost methodology required in rule 3701-36-14 of the Administrative Code.
- (B) For the purposes of this chapter, STS designers shall demonstrate the ability to perform the following tasks required for STS designs through the submission of complete and accurate designs to the board of health:
- (1) Estimate STS flows including, daily design flows, and any expected variations and estimate pollutant concentrations and mass loads exceeding typical residential sewage strength as defined in paragraph (C) of rule 3701-29-11 of the Administrative Code.
  - (2) Interpret and evaluate all site specific information including the soil evaluation, site conditions, site prohibitions and information provided by the owner to determine feasible STS options that will meet the requirements of this chapter.
  - (3) Evaluate site hydraulics and understand how the proposed STS integrates with the site topography and grade to site the STS.
  - (4) Select devices and components capable of meeting performance requirements based on knowledge of these rules and STS technologies approved by the director of health;
  - (5) Provide approximate installation and operation costs of feasible STS options to assist the owner in selection of the STS to design.
  - (6) Prepare a detailed design including all items outlined in paragraph (C) of this rule which fully complies with this chapter.
  - (7) Delineate by staking or flagging the proposed soil absorption areas on the site as they relate to topography and contour.
  - (8) Be available to clarify any questions with and make adjustments to the system design, layout, or operational concerns. It may be necessary for the designer to meet with the owner, soil scientist, installer, service provider, or local health department during, prior, and after the installation.
- (C) The designer or designee shall visit the site where the STS is to be located during the design process. The proposed location of a soil absorption component shall be staked or flagged on site to facilitate protection by the owner or his agent and to demonstrate that it can be installed as designed. Documentation submitted to the board of health shall be legible and contain sufficient detail to demonstrate compliance with the provisions of this chapter. At a minimum the STS design shall include:
- (1) A description of the dwelling and/or structure(s) to be served by the STS;
  - (2) Details on daily design flow, soil loading rates based on soil evaluation, length along contour, absorption area dimensions, and if needed, pump selection/sizing, and pressure distribution network information;

- (3) Rationale if varying from standards for items such as design flow, waste strength, or length along contour;
- (4) Identification and a description of all materials and system devices and components including septic tanks, dosing tanks, distribution piping, diversion mechanisms, and distribution materials;
- (5) Identification of applicable sizing requirements for all STS devices and components;
- (6) If applicable, identification of the approved system manufacturer and model to be used, manufacturer O&M instructions, and means of access for O&M equipment to service the STS;
- (7) Construction and installation notes for the system installer including manufacturer installation instructions, if applicable;
- (8) Copies of or electronic access to O&M requirements, manuals, and instructions for the owner and service provider;
- (9) A legible scaled site drawing on eight and a half inch by eleven inch or larger paper showing the layout of the STS on the site. The drawing shall illustrate:
  - (a) The proposed location of STS devices and components including the location of the soil absorption component as staked or flagged on site;
  - (b) The designated area for complete relocation and replacement of the STS as staked on site as required by paragraph (G) of rule 3701-29-06 of the Administrative Code;
  - (c) The approximate location of all items designated in paragraph (G) of rule 3701-29-06 of the Administrative Code and demonstrate that required isolation distances are met to both the proposed STS and the replacement area;
  - (d) The location of all surface features that may affect the operation or installation of the STS including, but not limited to, disturbed areas, drainage features, wooded areas, and hardscapes;
  - (e) The approximate location of soil borings and/or soil test pits; and
  - (f) North directional arrow;
- (10) If necessary or applicable at least one enlarged, detailed plan view drawing of the system. The drawing(s) shall illustrate:
  - (a) The proposed location and configuration of the system with proposed absorption area dimensions and elevations;
  - (b) Ground surface elevations and component elevations as necessary to ensure compliance with this chapter; and
  - (c) Any additional information requested by the board of health;
- (11) If applicable, pump selection information including the pump curve and system performance curve;
- (12) If applicable, pressure distribution network description and calculations; and
- (13) Any additional information required by the board of health.

**3701-29-11 Flow estimation and waste strength**

- (A) The owner or owner's agent shall provide information to the board of health and/or the system designer on the sources of sewage from the dwelling or structures to be served by a STS to document system design flow and waste strength in accordance with these rules. The board of health may require submission of building and plumbing plans including plumbing fixture details and other information as needed.
- (B) The daily design flow estimate for a STS shall comply with the following general provisions unless otherwise specified:
- (1) Except as provided in paragraphs (B)(4) and (B)(5) of this rule, the daily design flow for a HSTS shall be one hundred twenty gallons per day per bedroom with a minimum design flow of two hundred forty gallons per day.
  - (2) For a SFOSTS with periodic large daily flow, effluent may be stored to avoid exceeding the one thousand gallon per day treatment limit provided the peak design flow does not exceed three thousand five hundred gallons per day. When effluent is stored to avoid exceeding the one thousand gallon per day treatment limit, the design shall use time dosing and the appropriate tank capacity to store effluent during peak flows.
  - (3) The daily design flow for a SFOSTS shall be determined in accordance with table A-1 of rule 3745-42-05 of the Administrative Code or alternative daily design flow established by the director of health. The board of health may consider flow monitoring data in addition to or in place of the minimum design flow requirement in table A-1. If flow monitoring is used as the method of determining daily design flows, then daily design flow shall be at least one and a half to two times the measured average daily flows.
  - (4) An increase in the daily design flow estimate for a STS shall be required by the board of health when there is an indication that the flows established in accordance with paragraph (B)(1) or (B)(2) of this rule may be exceeded. Any required increase in daily design flow shall be documented on the installation permit and operation permit.
  - (5) A reduction in daily design flow for a STS may be approved by the board of health when information submitted indicates conditions that justify reduced flow such as low-flow fixtures, alternative toilets, or other circumstances that may warrant a reduction in daily design flow. Justification for a proposed reduction in daily design flow shall be included in the site review application and, if approved, shall be documented on the installation permit and operation permit. When actions are taken to reduce the flow to a STS, the design shall address increased waste strength due to the reduced flows.
- (C) The waste strength estimate for a STS shall be determined for design purposes. Waste strength for sewage received by a HSTS shall be considered typical residential sewage strength when, after primary treatment, the waste strength does not regularly exceed the TSS content of three hundred thirty milligrams per liter, the BOD<sub>5</sub> content of two hundred fifty milligrams per liter, or the fats, oils, and grease content of twenty five milligrams per liter. Waste strength estimates for SFOSTS shall be determined from the waste strength ranges in table A-1 of rule 3745-42-05 of the Administrative Code.
- (D) Any waste prohibited by UIC regulations for introduction into a SFOSTS shall be source separated and regulated by Ohio EPA.
- (E) When the waste strength for a STS is expected to exceed or has exceeded the typical residential sewage strength:

- (1) The use of additional treatment components that are approved by the director of health shall be included in the STS design prior to soil treatment and/or dispersal or a pretreatment component approved by the director for meeting specified effluent quality standards. The method of treatment to reduce waste strength shall be justified in the design, reviewed by the board of health for compliance with this chapter, and if approved, shall be documented on the installation permit and operation permit.
  - (2) Alternative soil loading rate values that vary from these rules may be used to address concerns of increased CBOD<sub>5</sub> loading from a STS. These alternative soil loading rates shall be documented and justified in the design including waste strength characterization information. Board of health approval for any increase in loading estimates shall be documented on the installation permit and operation permit.
- (F) A grease interceptor or automatic grease removal devices located inside buildings shall meet the requirements of rule 4101:3-10-01 of the Administrative Code. A sewage tank approved under rule 3701-29-12 of the Administrative Code may be used as an external gravity grease interceptor to reduce fats, oils and grease loading from a STS. The external grease interceptor shall be located, designed, and installed in a manner that will allow access for inspection and maintenance, including the following:
- (1) A source segregated inlet line, when feasible;
  - (2) The tank shall be sized to allow for a minimum of thirty minutes of retention time based on the peak flow from fixtures contributing fats, oils and grease; and
  - (3) Watertight access risers extended to grade with secure covers.
- (G) Removal of a garbage disposal may be used to address concerns of increased nutrient, total suspended solids, and biochemical oxygen demand loading and concerns with an increased frequency of septage removal.

**3701-29-12 Tanks, pumps and controls, and building sewers.**

- (A) Tanks subject to this chapter including, but not limited to, septic tanks, dosing tanks, pump vaults, HSTS holding tanks and privy vaults, grease traps or other applicable tanks shall be manufactured to be watertight and structurally sound in accordance with division (A)(17) of section 3718.02 of the Revised Code.
- (B) Except as otherwise specified in rule, tanks shall be composed of materials, manufacture, physical design requirements and joint and tank connections that are in accordance with one of the following:
- (1) ASTM C 1227;
  - (2) IAPMO/ANSI Z1000; material property standard;
  - (3) CAN/CSA-B66;
  - (4) ASTM Standard C 1613 for concrete grease interceptors; or
  - (5) Other standards approved by the director.
- (C) Septic tanks used in a STS shall be labeled in accordance with ASTM C 1227, IAPMO/ANSI Z1000, or CAN/CSA-B66 and shall comply with the following requirements and specifications:
- (1) Minimum liquid capacities:
    - (a) One to two bedrooms – one thousand gallons in one or two compartments.
    - (b) Three bedrooms – one thousand five hundred gallons in two tanks or compartments.
    - (c) Four to five bedrooms – two thousand gallons in two tanks or compartments.
    - (d) Six or more bedrooms – two thousand five hundred gallons plus an additional two hundred fifty gallons of tank capacity for each bedroom in two tanks or compartments.
    - (e) SFOSTS – one thousand gallons minimum in two tanks or compartments with at least two and one half times the daily design flow.
  - (2) In two compartment tanks, the first compartment shall not be less than one half or more than two-thirds of the total capacity of the septic tank and the transfer port in the center wall shall ensure transfer of liquid from the clear zone only. When using two tanks, the septic tanks shall be connected in series.
  - (3) The septic tank outlet, or the outlet of the last septic tank in series, shall include an effluent filter device that retains solids greater than one sixteenth inch in size. Effluent filter devices shall be certified to ANSI/NSF Standard 46 or be approved by the director. Effluent filter devices shall be sized to meet the estimated daily design flow for the system that the septic tank is used in.
- (D) Access openings, watertight risers, and lids shall be installed above the inlet and outlet of the tank in accordance with the following:
- (1) Access openings and risers shall provide a minimum twelve inch clear opening and allow adequate space for pumping of the tank and inspection and maintenance except for access openings of pretreatment components as specified in paragraph (J) of rule 3701-29-13 of the Administrative Code. Clear opening means the point at the smallest diameter within the access opening.



- (2) The connection of the riser to the tank and the connection of additional riser sections shall be watertight and prevent vertical and lateral movement of the riser.
  - (3) Riser joints must be watertight and use a gasket and/or sealant.
  - (4) Risers shall extend either to grade or above grade in a manner to prevent infiltration of surface or ground water.
  - (5) The cover or riser lid shall weigh a minimum of fifty pounds or be secured by mechanical means against unauthorized access.
- (E) An access opening, watertight riser, and cover shall be provided above the compartment wall with a minimum twelve inch clear opening to allow for adequate pumping, inspection, and maintenance in a two compartment tank unless the transfer port in the center wall is a pass through opening that allows a shared liquid level in both compartments.
- (F) Tanks shall be bedded, installed, and backfilled in accordance with manufacturer specifications and the product approval to assure the structural strength integrity of the tank. The tank shall be reasonably level to ensure the invert of the tank outlet is lower than the invert of the tank inlet.
- (G) After installation, the director or a board of health may require watertight field testing of any STS tank due to installation or pipe connection problems provided the testing is conducted in accordance with the manufacturer's field testing procedures provided as part of the product approval.
- (H) One year after the effective date of this rule, all tanks used in STS shall be approved by the director. The department of health shall maintain a list of approved tank models. A manufacturer's request submitted to the department of health for tank approval shall include, but is not limited to:
- (1) A complete application form as developed by the department of health;
  - (2) Structural and physical design information, including tank or component buoyancy calculations and associated anti-buoyancy measures, design drawings and material specifications for each model size and configuration to demonstrate compliance with this rule;
  - (3) Documentation of the total liquid capacity and tank volumes calibrated in one inch increments for each tank;
  - (4) A written watertight field test procedure. Manufacturers of precast concrete tanks may use the test procedure specified in ASTM C 1719;
  - (5) Detailed written installation instructions including but not limited to bedding and backfilling requirements, product specific procedures to address buoyancy concerns with the tank, and identification of all site and installation conditions where these procedures are necessary;
  - (6) Verification of tank structural strength and integrity for expected internal and external loads by proof of compliance with one of the following assurance review methods:
    - (a) Process assurance review. Annual certification of the manufacturer by the national precast concrete association, IAPMO research and testing, CSA quality management institute, or other methods approved by the director;
    - (b) Product assurance review. Certification of compliance with one of the following standards, as appropriate, by a registered professional engineer or ANSI approved testing facility for each model of septic tank:

- (i) ASTM C-1227 standard specifications for precast concrete septic tanks. The product assurance review under ASTM C-1227 shall include submission of results from structural proof testing which has been witnessed and certified by a registered professional engineer. The structural proof test shall consist of applying a negative air pressure (vacuum) and/or weight applied to the top of the tank to a determined load factor. For standard tanks designed to be buried with one foot to four feet of earthen cover, the calculated load factor requires that a tank be tested to a negative air pressure of four inches plus the placing of two thousand pounds of weighted material on a footprint of two feet by two feet placed in the center of the top of the tank as shown in figure 1. The calculated load factor shall be three hundred pounds per square foot lateral loads, and eight hundred pounds per square foot of top loading. The tank shall be certified as being structurally sound if it holds the pressure and weight for five minutes. The testing performed under this provision is intended to only be performed in the controlled environment of in-plant testing conforming to industry accepted test procedures;

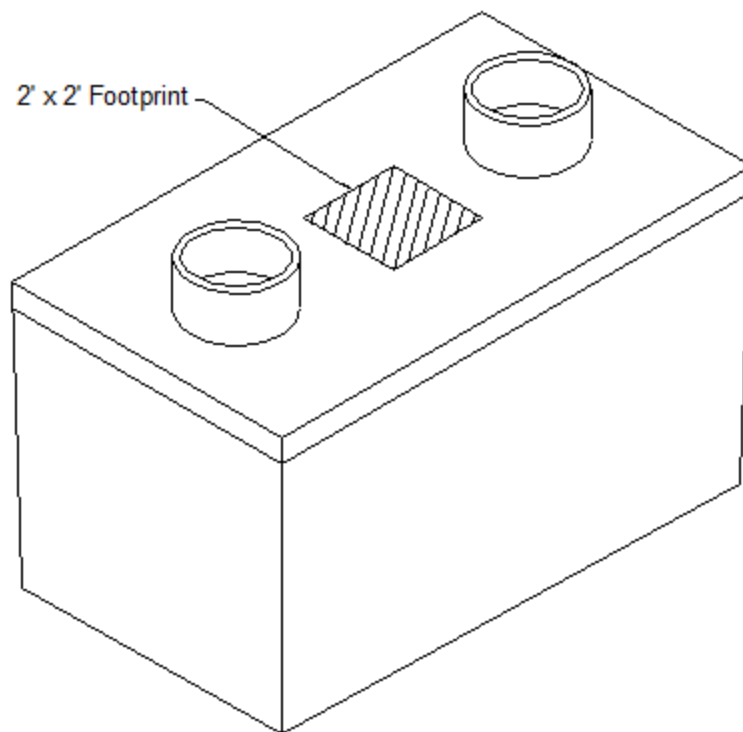

**Figure 1.**

- (ii) IAPMO/ANSI Z1000 standard for prefabricated septic tanks;
- (iii) CAN/CSA-B66 for prefabricated septic tanks and sewage holding tanks; or
- (iv) ASTM Standard C 1613 for concrete grease interceptors;
- (c) Submission of written certification of tank designs or drawings assuring structural strength and integrity for anticipated internal and external loads by a registered professional engineer. Certification shall include the reviewed designs and drawings and be stamped with the registered professional engineer's seal.
- (7) Documentation and verification of water-tightness testing by proof of compliance with one of the following assurance review methods:

- (a) Process assurance review. Annual certification of the manufacturer by the national precast concrete association, IAPMO research and testing, CSA quality management institute, or other methods approved by the director.
  - (b) Product assurance review. Certification of compliance with one of the following standards, as appropriate, by a registered professional engineer or ANSI approved testing facility for each model of tank:
    - (i) ASTM C-1227 standard specifications for precast concrete septic tanks unless proven under paragraph (H)(6)(b)(i) of this rule;
    - (ii) IAPMO/ANSI Z1000 property standard for prefabricated septic tanks;
    - (iii) CAN/CSA-B66 for prefabricated septic tanks and sewage holding tanks; or
    - (iv) ASTM Standard C 1613 for concrete grease interceptors.
  - (c) Field assurance review. Signed written certification provided by the manufacturer that all STS tanks shall be field tested as watertight in accordance with either ASTM C-1719 for precast concrete tanks, IAPMO/ANSI Z1000 standard for prefabricated septic tanks, CAN/CSA-B66 for prefabricated septic tanks and sewage holding tanks, or other methods approved by the director and as appropriate for the material and manufacture of the tank.
- (8) Identification of methods for tank repair and/or replacement in the event of watertight test, load or installation failure. Repairs of tanks shall be performed by the manufacturer in a manner ensuring that the repaired tank will conform to the requirements of these regulations.
- (9) Any additional information as required by the director.
- (I) Unless there is evidence of noncompliance with this rule and when there has been no change in the design or materials used in the manufacture of the tank, the department of health approval shall remain valid and a septic tank shall remain on the list upon verification of the required proof of compliance within the time frame or conditions of the assurance review method submitted by the manufacturer. When there has been a change in design or materials or a change in the submitted assurance review method, the manufacturer shall reapply in accordance with this paragraph. If a manufacturer fails to maintain compliance with this rule the department of health shall remove the septic tank model or the manufacturer from the list of approved septic tanks in accordance with Chapter 119. of the Revised Code.
- (J) Dosing tanks shall be designed and manufactured in accordance with the following:
- (1) Dosing tanks shall comply with the standards and specifications of this rule.
  - (2) Dosing tanks shall be selected to accommodate the volume below maximum drawdown, the maximum design dose including any drainback, and the design portion of the reserve and surge capacities as applicable. For the purposes of this chapter, reserve capacity shall be the tank capacity above alarm activation level.
    - (a) STS with time or demand dosed designs shall provide a reserve capacity for high water alarm events that is not less than one-half of the daily design flow.
    - (b) STS with time dosed designs shall accommodate combined reserve and surge capacities of not less than one hundred fifty per cent of the peak daily design flow. For the purposes of this

chapter surge capacity shall be the tank volume between the high water alarm level and the maximum drawdown point level.

- (c) When required by the manufacturer, the volume below maximum drawdown shall be sufficient so that the pump will remain submerged after a dosing event. For the purposes of this chapter volume below maximum drawdown shall be the volume below the pump off setting. A redundant off switch may be installed to prevent pumping below the design maximum drawdown point.
- (3) A septic tank second compartment or a second septic tank in series may be used for low volume dosing if all conditions cited above are met and a filtered step system or screened vault is used in lieu of, or in addition to, the effluent filter device required.
- (K) Effluent dosing pumps shall meet the following specifications:
  - (1) A pump shall be rated for effluent service by the manufacturer and must be third party or listed to the appropriate UL or CSA standard.
  - (2) The pump shall be properly sized to meet the design flow rate and total dynamic head requirements specified for the STS. The STS design shall include a graph of the pump curve showing that the pump can meet the design requirements of the network by calculation.
  - (3) A quick disconnect shall be accessible in the pump discharge piping with adequate lift attachments provided for removal and replacement of the pump and water level control assembly without having to either enter the dosing tank or pump the tank to lower the liquid level. When a check valve is used, a vent hole should be installed between the check valve and pump to prevent pump airlock.
  - (4) If any portion of the pump fittings or transport line is at a higher elevation than the soil absorption component, the system must be equipped with an air vacuum release valve or other suitable device to avoid siphoning.
  - (5) Replacement pumps and controls must meet the original design standards and criteria.
- (L) A dosing siphon or other similar device may be used if the STS design requirements, including the design flow rate, dose capacity, and low pressure distribution parameters, can be met and maintained.
- (M) Switches, controls, alarms, and electrical devices shall be listed to the appropriate UL or CSA standards, clearly and permanently labeled by the manufacturer and/or per the approved design, acceptable for the design, installed in a manner easily accessible for routine monitoring and maintenance, and shall comply with the following:
  - (1) Float switches, when used, must be mounted independent of the pump and transport line so that they can easily be removed from the dosing tank without disturbing or removing the pump;
  - (2) Except as required in paragraph (A)(5) of rule 3701-29-15.1 of the Administrative Code, controls associated with dosing of effluent shall provide a means to record dosing events or the ability to collect information to troubleshoot system malfunctions;
  - (3) Controls shall have both audible and visual alarms. Alarms and controls shall be on a commonly used household circuit. All other electrical components shall be on a different dedicated circuit than the alarms and controls. The board of health may require that the alarm be located in closer proximity to the dwelling or structure when the STS location is remote;
  - (4) Control panels and alarms shall be mounted in an easily accessible exterior location, a minimum of one foot above grade to bottom of lowest junction box and shall be field-tested to assure

compliance with the STS specifications, and shall include written instructions related to standard operation and alarm events; and

- (5) Failsafe shut-off mechanisms shall be required and installed for discharging off-lot systems under the household general NPDES permit and shall meet the requirements of the director's approval.
- (N) The board of health may require an electrical inspection to address concerns of safety or risk of injury.
- (O) STS components described in this rule shall be installed, operated and maintained as specified by the manufacturer and the approved design.
- (P) Except where gray water discharges to an approved GWRS via a separate building sewer, or approved alternative toilets are used, building sewers shall carry all sewage flow from the dwelling or structure, including gray water or other segregated sewage, and shall be connected to a STS in compliance with this chapter. Building sewers shall comply with the following:
  - (1) The elevation of a building sewer shall be aligned to accommodate the plan elevations of the subsequent STS components at a uniform grade of not less than one per cent or one eighth of an inch per foot. Designs should avoid sewer line slopes greater than ten per cent. The sewer shall be properly bedded in in situ soil or coarse aggregate that minimizes settling;
  - (2) A building sewer shall be watertight, have a minimum diameter of four inches, be Schedule 40 or SDR 21 or greater, and be constructed of durable material conforming to ASTM D2661 or ASTM D1527 for ABS plastic pipe or ASTM D1785, ASTM D2729, or ASTM D2665 for PVC plastic pipe. Pipe, fittings, and joining materials shall be chemically and physically compatible and ensure water-tightness; and
  - (3) No pipe elbows greater than forty five degrees are permitted.
- (Q) A building sewer shall allow for proper venting of STS components. Traps shall not be installed in a building sewer.
- (R) A cleanout shall be required outside each structure served by a STS when one is not provided inside the structure. Additional cleanouts shall be required in a building sewer at the point a building sewer pipe exceeds seventy-five feet and at every one hundred foot interval thereafter.
- (S) Casing or other form of protection shall be provided for any portion of a building sewer located in areas where soil or environmental conditions exist that could cause excessive additional loads on the sewer including vehicle traffic or excavation in or through disturbed or excavated soils.

**3701-29-13 Product standards, review, and operation and maintenance.**

- (A) Approved leaching trench products utilizing a non-gravel fines-free distribution system shall receive approval of the director through one of two processes as follows:
- (1) For the two product types meeting the description provided in paragraphs (A) (1)(a) and (A)(1)(b) of this rule, approval may be granted by the director after administrative review. Manufacturers or their authorized representatives whose chamber and bundled expanded polystyrene distribution media products meet the specifications in paragraphs (A)(1)(a) and (A)(1)(b) of this rule shall submit technical, design, performance, installation, and O&M information to support all manufacturer claims as requested by the director for administrative review. Installation information shall include a product-specific installation checklist for use by contractors and inspectors. The checklist shall provide enough information to guide installations and inspections. Upon administrative review the director may approve or disapprove the chamber or expanded polystyrene bundle system. If the director disapproves the manufacturer's request, the manufacturer may seek approval through the process specified in section 3718.04 of the Revised Code
    - (a) Chamber distribution products eligible for administrative approval shall:
      - (i) Eliminate the need for gravel leaching trenches and replace it with an open bottom, plastic chamber;
      - (ii) Provide adequate void space for the passage and temporary storage of effluent. Adequate void space shall be considered the volume of void space provided by the equivalent area of a gravel leaching trench;
      - (iii) Provide suitable effluent distribution and provide an interface with the infiltrative surface of the trench bottom and side wall soil for absorption of the effluent; and
      - (iv) Be certified by the IAPMO to meet Property Standards PS 63-2005 et seq.
    - (b) Bundled expanded polystyrene distribution media products eligible for administrative approval shall:
      - (i) Eliminate the need for traditional gravel and replace it with a perforated pipe surrounded by tightly packed expanded polystyrene aggregate and enclosed in polyolefin netting. When used in combination with expanded polystyrene bundles containing a perforated pipe, additional bundles are not required to contain a perforated pipe;
      - (ii) Provide adequate void space for the passage and temporary storage of effluent while maintaining a stable density throughout the life of the system. Adequate void space shall be considered the volume of void space provided by the equivalent area of a gravel leaching trench;
      - (iii) Support the distribution pipe where required, provide for suitable effluent distribution, and provide an interface with the infiltrative surface of the trench bottom and side wall soil for absorption of the effluent;
      - (iv) Maintain the integrity of the excavation, support soil backfill and cover material, and weight of equipment used in backfilling;
      - (v) Be fabricated from non-decaying and non-deteriorating materials, meeting applicable industry standards that do not leach unacceptable chemicals when exposed to effluent and the soil environment; and

- (vi) Be certified by the IAPMO to meet Guide Criteria IGC 276-2011 et seq.
- (B) A pretreatment component shall only be permitted by a board of health for use in a STS if approved by the department of health in accordance with this rule and section 3718.04 of the Revised Code.
- (1) The department of health shall maintain a list of approved pretreatment components and the associated treatment level the product is listed to obtain.
  - (2) Except as provided in paragraph (D) of this rule, a listed pretreatment component shall be approved for a maximum period of five years and may be reevaluated at any time during the approval period when there is evidence of noncompliance with this rule or there has been a change in design of the pretreatment component. A manufacturer may apply for renewal of its approval at any time prior to the end of the approval period, at which point the product will be reevaluated.
  - (3) Information submitted for renewal or reevaluation shall include an updated list of distributors and service providers and may include additional field or test data, design changes to the product or treatment train, installation or operation modifications, and changes in service provider availability. The department of health may require field testing or monitoring for the purposes of renewal or reevaluation. If a manufacturer does not submit information in accordance with this paragraph, the department of health shall remove the pretreatment component or the manufacturer from the list of approved pretreatment components in accordance with Chapter 119. of the Revised Code.
  - (4) Pretreatment components are subject to review by the director of health for compliance with the conditions of approval and applicable law and rules. A pretreatment component may be reevaluated at any time when there is evidence of noncompliance with approval conditions or for other reasons deemed necessary to assure compliance. Upon review, if there is a determination of noncompliance, a pretreatment component or the manufacturer may be removed from the approved list in accordance with Chapter 119. of the Revised Code.
- (C) Aerobic type treatment systems and applicable special device approvals previously approved by the director of health prior to January 1, 2007 shall be conditionally listed as meeting the CBOD<sub>5</sub> and TSS standard in paragraph (A) of rule 3701-29-14 of the Administrative Code for a maximum period of one year, during which time, the manufacturer of the system or device may submit an application for review
- (D) Pretreatment components reviewed by the sewage treatment systems technical advisory committee and/or approved by the director of health after January 1, 2007 shall continue to be approved. The five-year approval period for these pretreatment components shall begin upon the effective date of these rules.
- (1) Products approved prior to January 1, 2009 shall be approved through December 31, 2020;
  - (2) Products approved between January 1 and December 31, 2009 shall be approved through December 31, 2021;
  - (3) Products approved between January 1, 2010 and December 31, 2012 shall be approved through December 31, 2022;
  - (4) Products approved between January 1, 2013 and December 31, 2014 shall be approved through December 31, 2023;

If director approves the renewal application, the five-year approval period for these pretreatment components shall begin upon the date of renewal.

- (E) In accordance with division (A)(17) of section 3718.02 of the Revised Code, pretreatment components shall be structurally sound and watertight except for those pretreatment components that are approved to

disperse effluent directly to the soil, sand bed or gravel. Pretreatment components shall be clearly and permanently labeled by the manufacturer and/or per the approved design. Where appropriate, anti-flotation measures shall be provided.

- (F) Pretreatment components shall be designed to have effluent sampling capability at the endpoint of the treatment process prior to dispersal to the soil or discharge to the surface and be designed with consideration of accessibility and safety and provide the capability to collect a sample in accordance with paragraph (F)(2) of this rule. These components shall be designed and sampled as follows:
- (1) Sample ports for discharging systems must meet the following specifications to allow for proper collection of samples:
    - (a) The sample port shall be constructed from watertight material with watertight joints;
    - (b) The invert of the inlet shall be installed at least eight inches above the bottom of the sample port;
    - (c) The sample port shall be constructed and installed in such a way as to allow for at least two inches of fall between the invert of the inlet and outlet of the sample port;
    - (d) The sample port shall have a minimum clearance of eight inches for sample ports less than two feet deep or twelve inches for sample ports between two feet and six feet deep at the point of sample collection between the inlet and outlet pipes; and
    - (e) Sampling ports for discharging systems shall allow samples to be collected from a free-falling stream of sufficiently low flow to enable proper sample collection at the end of the discharge pipe in the provided inspection port.
  - (2) Samples shall be collected in compliance with all applicable standards and ODH-provided sampling guidance or other manufacturer produced, product specific collection guidance and the following:
    - (a) Grab samples shall be collected from a free-falling stream of sufficiently low flow to enable proper sample collection at the end of the discharge pipe, valved pressured discharge piping, or in the provided inspection port;
    - (b) Unless otherwise unable to collect a free-flowing grab sample, sampling should not be collected from stagnant water or inside a component of the system; and
    - (c) Composite samples may be collected in lieu of grab samples for suspended solids, CBOD<sub>5</sub> and nutrients, if allowed by the general household NPDES permit.
  - (3) Manufacturers who want to collect samples from a valve in the pressurized discharge piping located within the post aeration tank shall submit written guidance for the proper collection of samples from the valve to the department of health.
  - (4) Sampling ports for soil based treatment components may be required as authorized by the director and specified in the application and approval of the product.
- (G) Disinfection components shall not discharge disinfection residuals to a soil absorption component.
- (H) Installation shall be conducted in a manner consistent with manufacturer and designer specifications to allow for proper O&M and monitoring of the pretreatment component.
- (I) All pretreatment components shall have written O&M instructions with approved maintenance frequencies for service and the registered installer shall provide the O&M instructions to both the owner and the board



of health as a condition of installation approval and approval by the director of health. A board of health may require a copy of a manufacturer's instructions for the O&M of a system to be filed with the board prior to the installation and use of the system in the health district. A board of health and the manufacturer shall provide a copy of the O&M instructions upon written request to the system owner.

- (J) Covers and risers shall be secured and be easily accessible for monitoring and maintenance of the entire pretreatment component and be installed at or above grade to prevent infiltration of surface water. Covers and risers used for service of pretreatment components shall be installed in accordance with manufacturer requirements or director's approval. Vented access lids must be installed above grade in accordance with manufacturer requirements or director's approval.
- (K) Pretreatment components not subject to review and approval under section 3718.04 of the Revised Code shall be submitted to the department for review and subsequent approval or disapproval by the director. Certification with one of the following third-party testing protocols shall constitute sufficient proof of compliance with the CBOD<sub>5</sub>/TSS standard in paragraph (A) of rule 3701-29-14 of the Administrative Code:
  - (1) ANSI/NSF Standard 40 certification of compliance with current ANSI/NSF Standard 40 by an ANSI/CSA accredited third party certifier;
  - (2) BNQ Standard NQ 3680-910CE; or
  - (3) N Standard EN 12566-3.
- (L) In accordance with division (A) of section 3718.04 of the Revised Code, a manufacturer seeking approval for the installation and use of a sewage treatment system or a component of a system in this state that differs in design or function from systems or components of systems the use of which is authorized in rules adopted under section 3718.02 of the Revised Code shall submit an application to the director and the sewage treatment systems technical advisory committee for review and recommendation for approval or disapproval by the director of health.
- (M) Manufacturers of sewage treatment system treatment trains approved for use in the state of Ohio shall be required to provide documentation as proof of certification for those individuals or companies qualified to oversee installation, install, or service their products. Qualified individuals or companies shall retain said documentation and provide it to the department or board of health upon request.
- (N) Manufacturers of pretreatment components shall be required to maintain a list of system installations and locations either directly or through a local distributor. The list shall be accessible to the board of health or the department of health upon request.
- (O) Manufacturers of sewage treatment systems and treatment trains approved for use in the state of Ohio shall be required to provide training, certification, recertification and related documentation as applicable to service providers, installers and system owners on the proper installation, operation and maintenance of the component or system. Manufacturers shall ensure that there is more than one service provider reasonably accessible to owners of installed systems, and that parts and special tools are readily available.
- (P) STS pretreatment components shall be operated, maintained, and monitored as necessary to ensure compliance with any applicable effluent quality standards established in this rule or the final effluent limitations set forth in a NPDES permit issued by the Ohio EPA. Devices critical to the performance of pretreatment components shall be maintained as manufacturer's original equipment matching the system configuration approved by the director.
- (Q) Pretreatment components and systems installed to meet the effluent quality standards set forth in a general household NPDES permit issued by the Ohio EPA shall meet the following requirements:

- (1) The pretreatment component and/or full treatment train shall include a failsafe mechanism that provides an audible and visual alarm in the event of a component malfunction and one of the following mechanisms to ensure proper response:
    - (a) An integrated pump lock-out that prevents the discharge or forward flow of effluent that does not meet the effluent quality standards set forth in a NPDES permit. Pump tanks with integrated pump lock-out features designed to prevent discharge of effluent are exempt from the requirements of paragraph (J)(2) of rule 3701-29-12 of the Administrative Code; or
    - (b) A remote telemetry device to automatically notify the service provider and, if required, the board of health, in the event of a system alarm event or system malfunction; and
  - (2) Installation of a sampling port that meets the requirements of paragraph (F) of this rule at the end of the treatment train. The point of discharge shall have sufficient freeboard to prevent the backup of surface water into the system.
- (R) Tertiary treatment devices designed to provide additional treatment for discharging systems that are unable to meet the effluent quality standards of the household general NPDES permit shall be reviewed by the sewage treatment systems TAC and approved or disapproved by the director in accordance with section 3718.04 of the Revised Code. Boards of health may permit the addition of tertiary treatment devices on STS installed under the coverage of the household general NPDES permit to abate public health nuisances as defined in division (A)(4) of section 3718.011 of the Revised Code. Boards of health shall maintain a list of tertiary treatment devices installed within their jurisdiction.

3701-29-13

## APPENDIX A Low Pressure Dosed Sand Filters

### I. Introduction

Low pressure dosed sand filters (LPDSF) are aerobic, fixed-film bioreactors that are capable of treating septic tank effluent (or in some cases effluent from aeration treatment units) before it is dispersed into the soil. A low pressure dosed sand filter is constructed below grade, covered with soil, and contained within a watertight PVC liner.

This design was developed by members of the Ohio Department of Health Sewage Treatment Systems Technical Advisory Committee in response to the statewide need for a pretreatment device capable of achieving the standards outlined below without the use of electricity for system designs where the use of electricity is not feasible due to system location or social and religious beliefs. LPDSF are designed to provide for the treatment of typical domestic septic tank effluent before dispersal to soil. This design uses a siphon, or combination of siphons to pressurize the distribution network. This network design has been tested and has shown the ability to provide even distribution across the surface of the sand filter.

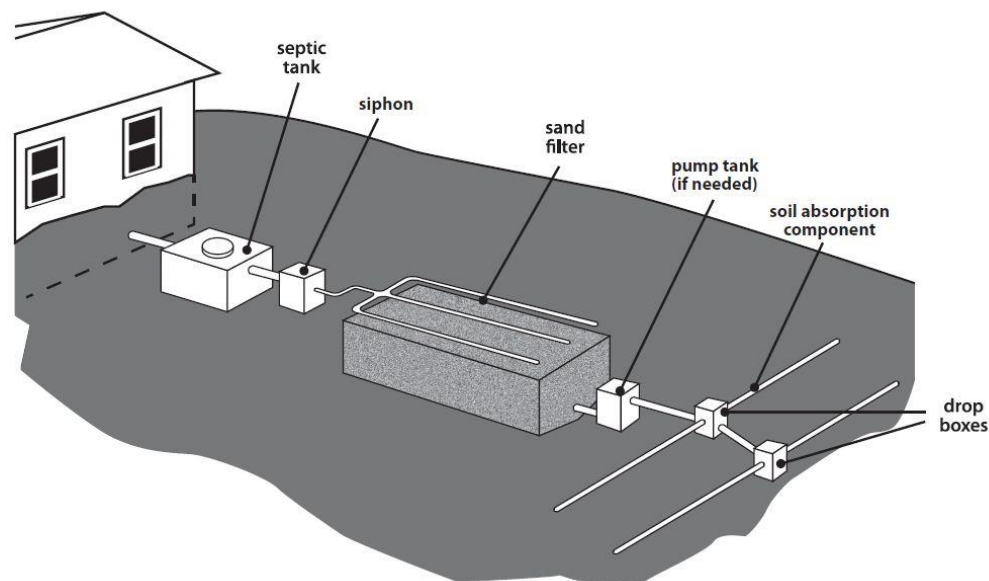

**Figure 1. Low Pressure Dosed Sand Filter**

## II. Limitations and Conditions for Use

- (A) A LPDSF designed in compliance with this section is approved for meeting the BOD<sub>5</sub> and TSS standard for a reduction in the size of a soil absorption component and the ten thousand CFU per one hundred milliliter fecal coliform standard for a twelve inch soil depth credit.
- (B) Although a septic tank or an approved pretreatment device (such as an aerator) must be used as primary treatment for a sand filter, the design may not combine reductions in the area of the soil absorption component or credits in the vertical separation distance.
- (C) In all cases, components must be watertight with sealed entries and exits for piping.
- (D) A sand filter designed in accordance with this Appendix is approved to accept a maximum daily design flow of 360 GPD. Two alternatively dosed LPDSF shall be installed when the daily design flow is expected to exceed 360 GPD but is calculated to be below 720 GPD.
- (E) Sand filters shall never be placed in surface depressions.
- (F) Systems treating wastewater with high concentrations of grease may require the use of a grease trap, as determined by the designer or board of health. Designs shall define, in detail, any and all measures for proper treatment of high strength wastewater.
- (G) Septic tanks must be sized in accordance with paragraph (C) of rule 3701-29-12 of the Administrative Code.

## III. Sand Filter Design

- (A) A LPDSF shall be sized in accordance with Table 1 of this appendix and the following:
  - (1) When multiple LPDSF are to be used, the dosing method and design of each LPDSF shall meet the criteria outlined within this Appendix.
  - (2) LPDSF must be sized based on a daily design flow of 120 GPD per bedroom or as otherwise justified for daily peak flow variations or for SFOSTS flows per rule 3701-29-11 of the Administrative Code.
  - (3) When the daily average flow from a dwelling is expected to exceed sixty per cent of a peak daily design flow of 120 GPD per bedroom, the peak daily design flow shall be increased accordingly.

Sand filter dimensions	18 feet X 20 feet
Sand filter area	360 square feet
Main length	8 to 10 feet
Main size	2 inch
Manifold size	1 ½ inch
Lateral length	8 feet
Lateral size	1 ½ inch
Lateral number	12
Lateral spacing	28 inches
Orifice size	3/16 inch
Orifice number	54
Orifice spacing	2 feet
Design dose volume	25.5 gallons
Design dose length	46 seconds
Design dose per orifice	64 ounces
Design head at end of the lateral	13 inches
Static Head (invert of main – invert of manifold)	13 inches
Drain down (height) in the dosing chamber during a dosing event	9.5 inches

**Table 1. Low Pressure Distribution Sand Filter Design Specifications**

(B) A buried sand filter must use a polyvinyl chloride liner.

- (1) The polyvinyl chloride liner shall have a thickness of at least thirty mil, demonstrate adequate tensile properties, tear resistance, temperature resistance, resistance to soil burial, dimensional stability, and hydrostatic resistance to operate as a watertight liner for the buried sand filter.
- (2) The polyvinyl chloride liner must be installed over a three inch layer of sand. The liner must have factory-fabricated boots suitable for field bonding onto the liner to facilitate the watertight passage of piping through the liner.
- (3) The location where pipes enter the sand filter through the liner must be water tight. "Pipe boots," flexible pipe attachments that seal against the liner and the pipe, must be sized correctly and installed following the manufacturers requirements.
- (4) Patches, repairs, and seams must have the same physical properties as the parent material and be approved by the manufacturer of the liner.

- (5) A support structure for the liner shall be constructed to be free of any sharp points protruding toward the liner. The space between the structure walls and the excavation shall be filled with sand or other flowable aggregate.
  - (6) Installation of the liner must take place during favorable weather conditions and meet the manufacturer's specifications.
  - (7) The liner shall extend to a height above saturated soil and must be sufficiently higher than any adjacent areas where surface water may pond.
- (C) The sand media used in the filter shall be natural, washed sand with not more than five per cent passing the No. 200 (75  $\mu\text{m}$ ) sieve as determined by ASTM C117, "Test Method for Material Finer than 75  $\mu\text{m}$  (No. 200) Sieve in Mineral Aggregates by Washing." The sand must be installed to a depth of no less than 24 inches. For the purpose of this document, natural sand is defined as naturally deposited silica based sand not manufactured by mechanical processing such as crushing of rock or coarse aggregates.
- (1) Buried sand filters must use sand with an effective size of 0.5 to 1.0 millimeters and a uniformity coefficient of 4 or less.
  - (2) Covered sand filters shall use sand with an effective size of 0.3 to 1.0 millimeters and a uniformity coefficient of 4 or less.
- (D) An underdrain must be placed beneath the filter media for the purposes of collection and ultimate dispersal of effluent to the soil absorption unit (see figure 2 of this appendix).
- (1) The design shall specify the means by which the underdrain is protected from the infiltration of filter media.
  - (2) The addition of vent pipes to the underdrain will increase air flow through the filter and should be considered as part of the design. Vent pipes shall terminate above grade.
  - (3) Underdrain supporting layers and effluent collection media shall comply with the following:
    - (a) Designs using gravel-less chamber or bundled polystyrene products to construct the underdrain shall include and follow manufacturer recommendations.

- (b) Designs using aggregate to bed the underdrain and construct supporting layers shall meet the following specifications:
- (i) The underdrain shall be constructed with rigid perforated pipe and laid in good alignment and level. The underdrain must be installed with two layers of aggregate, herein referred to as the supporting layers.
  - (ii) The underdrain shall be surrounded and covered with at least six inches of aggregate meeting the sizing requirement for coarse aggregate.
  - (iii) A second, three inch layer of finer aggregate shall be washed with not more than five per cent passing the No. 200 (75  $\mu\text{m}$ ) sieve as determined by ASTM C117, "Test Method for Material Finer than 75  $\mu\text{m}$  (No. 200) Sieve in Mineral Aggregates by Washing" and shall be durable with a hardness of 3 or greater on the Moh's Scale of Hardness, meeting a sizing requirements for AASHTO M 43 sizes 7 to 8 and shall be placed over the six inch supporting layer described in paragraph (III)(D)(3)(b)(ii) of this appendix. The sand will shall be placed over this supporting layer.
- (E) Sand filters shall be covered to prevent the infiltration of precipitation and surface water.
- (1) A geotextile filter fabric shall be installed over the gravel, chambers or expanded polystyrene bundles;
  - (2) A six inch soil cover shall be installed over the geotextile filter fabric. The soil cover shall consist of topsoil, or similar soil mixture, which allows for oxygen transfer, and is capable of supporting vegetative growth.
- (F) Sand filters shall include no less than two observation ports that extend to the interface of the sand and supporting layer. A sand filter shall also include no less than two observation ports that extend to the interface of the distribution area and sand when the surface is not exposed.
- (1) Each observation port must be placed away from points of application and shall be installed with a valve cap or plug.
  - (2) Diversion collars may be installed to discourage applied effluent from short circuiting the filter along vent pipes.

- (3) Installation of more than the minimum number of observation ports may be necessary for adequate observation of the sand surface and supporting layer surface during routine operation and maintenance for some designs.
- (G) Access, for the purposes of sampling, must be provided in the discharge line between the sand filter and the soil absorption component in accordance with paragraph (F)(1) of rule 3701-29-13 of the Administrative Code.

#### IV. Low Pressure Distribution Network

- (A) Incremental volumetric control of low pressure distribution is required. The distribution of the network described below has been tested and reviewed by TAC. Alternate designs or variations from this design are prohibited. The complete distribution network must consist of properly pressure rated polyvinyl chloride (PVC) piping and fittings meeting or exceeding industry standards. The selected piping must prevent settling and damage under normal load and operating conditions. All distribution network connections shall be watertight. The design plan shall conform to the network configuration outlined below:
  - (1) The dosing chamber shall have a diameter of 30 inches and have a minimum height of 42 inches. The dosing chamber shall be watertight and structurally sound.
  - (2) The siphon shall be a commercially manufactured, three inch unit capable of completing the 25.5 gallon dose in 46 seconds (+/- seven seconds). The reducer between the three inch siphon and the two inch main shall be installed vertically and shall not be installed horizontally in any case (see figures 5 and 6 of this appendix).
  - (3) The main piping shall be a minimum of eight feet long and shall not exceed ten feet in length, constructed with two inch PVC piping and shall be constructed per the drawings (see figure 4 of this appendix).
  - (4) The manifold shall be constructed with 1½ inch PVC piping and shall be constructed per the drawing (see figure 4 of this appendix). A two inch cross must be installed at the intersection of the manifold and main. A maintenance port must be installed in the distribution line for the purpose of energizing the distribution network for routine maintenance. Ball valves must be installed in the manifold to allow isolation of each half of the sand filter, in the main to allow for its flushing, and preceding the maintenance port to allow for it to be shut



off during normal operation. A service box must be installed to access each valve and the maintenance port (See figure 7 of this appendix).

- (5) Twelve laterals shall be constructed with 1½ inch PVC piping. Each lateral shall be eight feet long. Laterals shall be spaced at 28 inch intervals along the distribution surface of the filter. Each lateral shall include a turn-up and ¾ inch air gap/ bleeder per the drawing for routine maintenance (See figure 8 of this appendix).
    - (a) Turn-ups and valves, for the purpose of flushing and cleaning the distribution system, must be installed at the end of each distribution line. A valve box must be provided at the end of each lateral to house the turn up and valve.
  - (6) The distribution network shall be constructed with 54 orifices that are 3/16 inch in size. The orifices shall be spaced at two foot intervals along the length of the laterals.
  - (7) The dose shall deliver 25.5 gallons of effluent to the sand filter per dose for an orifice dose rate of 64 ounces. The dose shall be measured at startup to ensure small incremental doses.
  - (8) The sand filter bed shall have dimensions of 18 feet by 20 feet for a design area of 360 square feet.
  - (9) The design head at the networks furthest lateral is 13 inches +/- 1.5 inches. The head shall be measured at the end of each lateral at startup.
  - (10) Orifices shall be orientated down.
- (B) A low pressure dosed filter design must specify how the uniform distribution of the effluent across the surface of the sand filter will be ensured.
- (1) Wastewater shall be applied within a layer of aggregate above the sand media. The aggregate shall be washed with not more than five per cent passing the No. 200 (75 µm) sieve as determined by ASTM C117, "Test Method for Material Finer than 75-µm (No. 200) Sieve in Mineral Aggregates by Washing" and shall be durable with a hardness of three or greater on the Moh's Scale of Hardness.
  - (2) If approved gravelless chamber or bundled polystyrene is to be used, the design shall include and follow manufacturer recommendations.

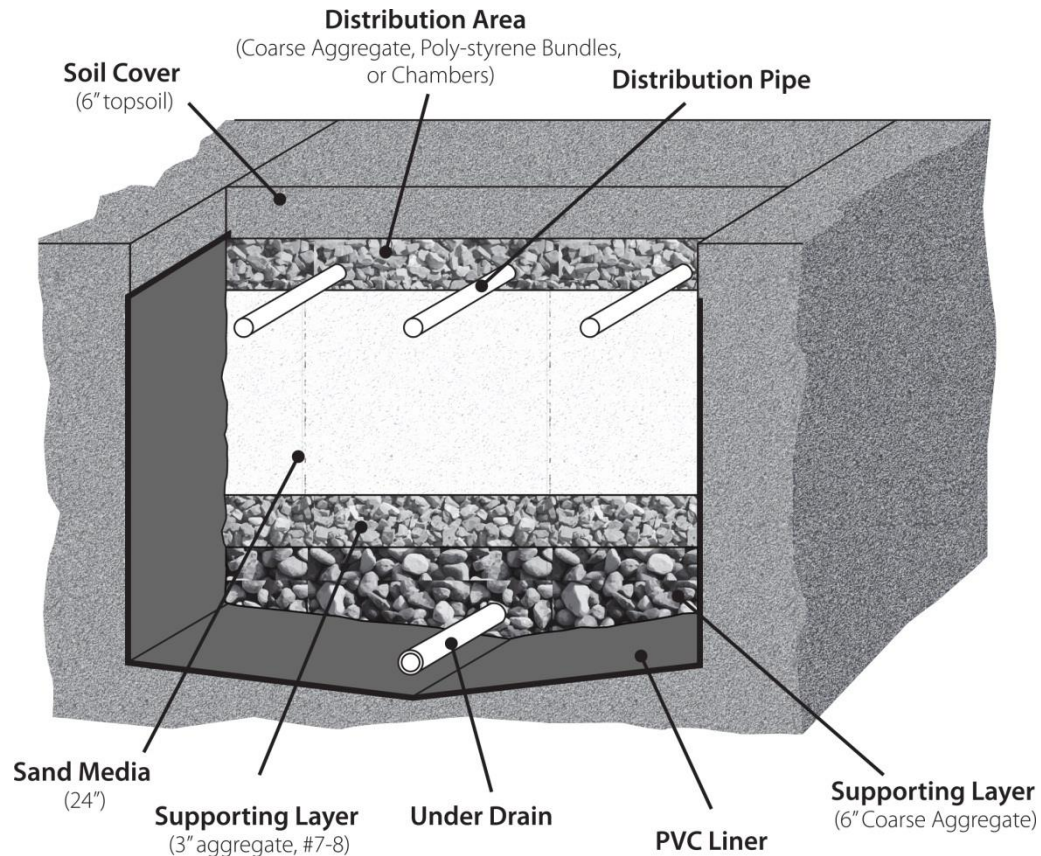

**Figure 2 Buried Low Pressure Dosed Sand Filter Cross Section**

## V. Site Preparation and Installation

- (A) Berms, surface grading or other site modifications shall be required as necessary to keep surface water from draining into the sand filter.
- (B) Low pressure distribution sand filters shall never be placed in surface depressions.
- (C) In all cases, units must be watertight with sealed entries and exits for piping.
- (D) Aggregate and media delivered to the site should be tested against design-sizing specifications. All aggregate and media shall be stored, loaded, transported, and installed in such a way as to avoid contamination of the material.

- (E) Filter media shall be placed in such a way as to avoid internal layering. Placing the sand by slurry or dropping the sand from a height of several feet should be avoided, because it promotes segregation by grain size.
- (F) Sand should be placed into the sand filter in six to eight inch lifts. Each lift should be wetted and then lightly settled. Light settling may be accomplished by walking on the sand.
- (G) The filter media surface shall be level and smooth.
- (H) The soil cover shall be graded to discourage the ponding of surface water and seeded to promote quick vegetation growth as soon as possible after construction and inspection of the sand filter.
- (I) Baseline measurements, for future O&M and monitoring, must be measured and recorded before STS approval by the board of health. Baseline measurements and monitoring information shall include but is not limited to a measurement of the distal operating head of each lateral. As-built records including baseline measurements and O&M instructions shall be provided to the owner, service provider, and the board of health.
- (J) The commercial siphon dose unit shall be connected to the main with a union or other non-permanent, serviceable connector for removal and adjustment.

## VI. Operation and Maintenance

- (A) The LPDSF shall be operated, maintained, and monitored as required by the operation permit issued by the board of health.
- (B) A service agreement for a pretreatment component used in a system with a LPDSF shall include the maintenance and monitoring of all system components.
- (C) In conjunction with any operation permit conditions or O&M provisions required by the board of health, the O&M of a LPDSF shall include but is not limited to:
  - (1) Checking vegetative cover for erosion or settling and any evidence of seepage on buried LPDSF.
  - (2) Flushing of distribution laterals.
  - (3) Checking for ponding in the distribution area.

- (4) Monitoring the dose volume and operating pressure head of the distribution system.
- (5) Checking for any surface water infiltration or clear water flows from the dwelling or structures into the system components or around the LPDSF.

#### Pictures and Drawings

Provided by: Steve Tricamo and Infiltrator Systems, Inc.

The following pictures and drawings are provided for contractor, homeowner, and local health department convenience. In no way should the pictures and drawings provided in this attachment be construed as contradictory or as a replacement to the guidelines provided within the appendix. The mention of trade names or commercial products in this document does not constitute endorsement or recommendation for use by the Ohio Department of Health.

### Sand Filter Detail Sand Filter with Aggregate

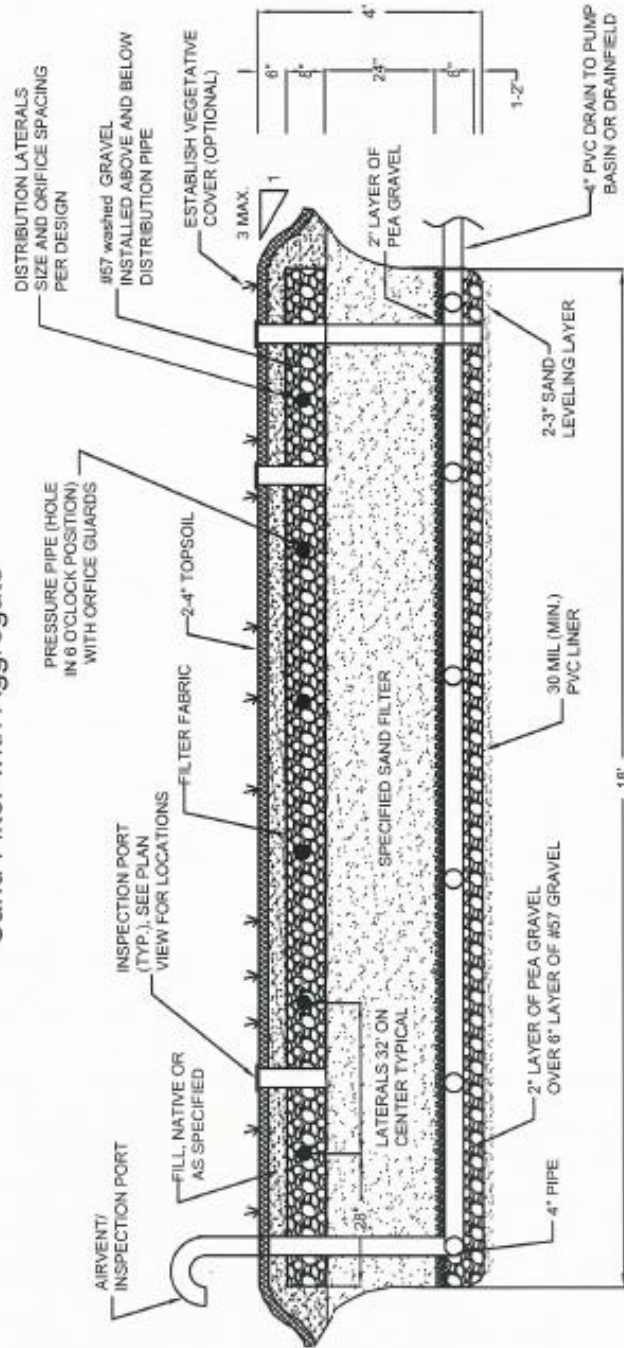

Schematic Only: Actual Dimensions Based on  
360gpd Design

Figure 3. Sand Filter Diagram

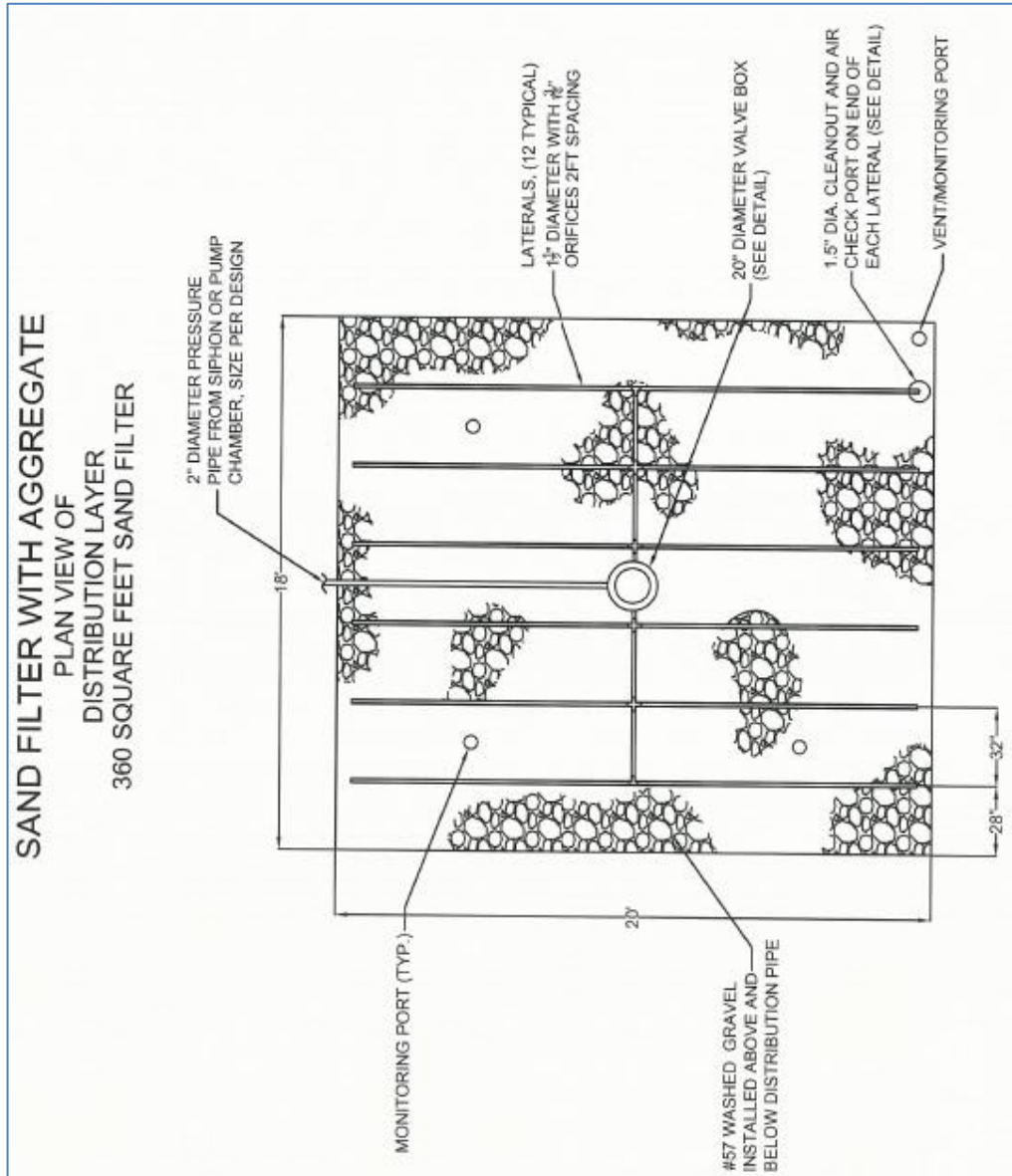

Figure 4. Plan View of Sand Filter Distribution Layer



The siphon is connected to the main with a union or other non-permanent, serviceable connector for removal and adjustment.



**Figure 5. Dosing siphon - external view**



**Figure 6. Dosing siphon - internal view**



**Figure 7. Service box within the manifold line**

Ball valves are installed in the manifold to allow isolation of each half of the sand filter when flushing the distribution network



**Figure 8. Turn-up and 3/4 inch air gap/ bleeder at the end of each lateral for routine maintenance**



3701-29-13

## APPENDIX B Timed Dosed Sand Filters

### I. Introduction

Time dosed sand filters (TDSF) are aerobic, fixed-film bioreactors that are capable of treating septic tank effluent (or in some cases effluent from aeration treatment units) before it is discharged into the soil (leaching trenches or sand mound system). Two types of TDSF can be used and are described within this appendix. A covered sand filter has walls which extend above the surface of the ground. The filter is contained in a rigid basin (typically concrete) and is protected from adverse weather conditions and temperatures, including precipitation, by a constructed cover. A buried sand filter is constructed below grade, covered with soil, and contained within a watertight PVC liner.

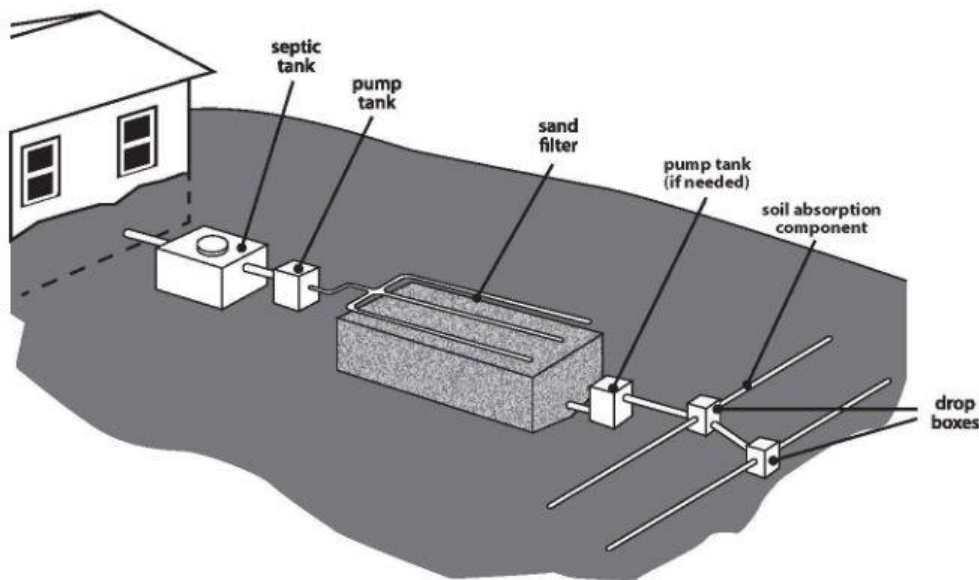

**Figure 1. Time Dosed Sand Filter**

### II. Limitations and Conditions for use

- (A) A TDSF designed in compliance with this section shall be approved for meeting the BOD<sub>5</sub> and TSS standard for a reduction in the size of a soil absorption component and the one thousand cfu per one hundred milliliter fecal coliform standard for a twenty-four inch soil depth credit.
- (B) Although a septic tank or an approved pretreatment device (such as an aerator) must be used as primary treatment for a sand filter, the design

may not combine reductions in the area of the soil absorption component or credits in the vertical separation distance.

- (C) In all cases, components must be watertight with sealed entries and exits for piping.
- (D) Sand filters shall never be placed in surface depressions.
- (E) Systems treating wastewater with high concentrations of grease may require the use of a grease trap, as determined by the designer or board of health.

### III. Sand Filter Design

- (A) A fabricated tank or polyvinyl chloride liner may be used to construct the filter basin within the following specifications:
  - (1) A covered sand filter must use a fabricated tank. A fabricated tank and all connections must be structurally sound, watertight, and designed specifically for the purposes outlined in this Appendix. The walls of the filter must extend no less than six inches above natural grade.

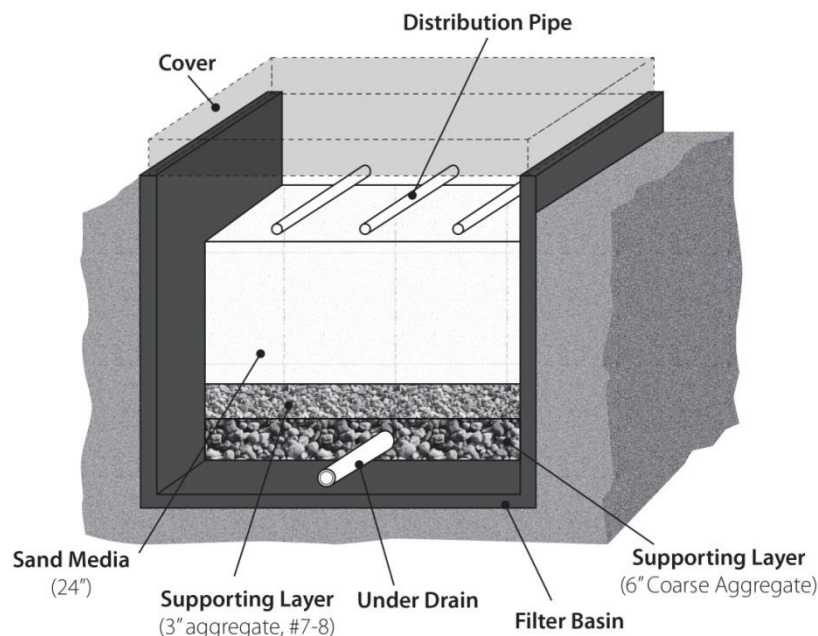

**Figure 2. Covered time-dosed sand filter (fabricated tank)**

- (2) A buried sand filter must use a polyvinyl chloride liner.
- (a) The polyvinyl chloride liner shall have a thickness of at least thirty mil, demonstrate adequate tensile properties, tear resistance, temperature resistance, resistance to soil burial, dimensional stability, and hydrostatic resistance to operate as a watertight liner for the buried sand filter.
  - (b) The polyvinyl chloride liner must be installed over a three inch layer of sand. The liner must have factory-fabricated boots suitable for field bonding onto the liner to facilitate the watertight passage of piping through the liner.
  - (c) Boots must be sized correctly and installed following the manufacturers requirements.

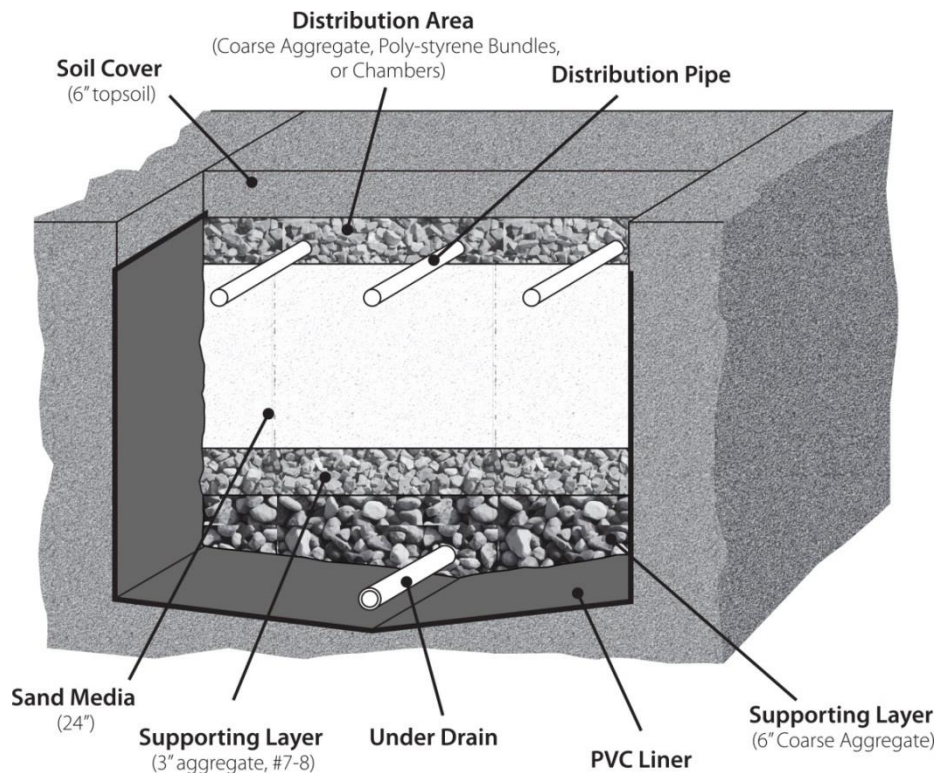

**Figure 3. Buried Time Dosed Sand Filter**

- (d) Patches, repairs, and seams must have the same physical properties as the parent material and be approved by the manufacturer of the liner.

- (e) A support structure for the liner shall be constructed to be free of any sharp points protruding toward the liner. The space between the structure walls and the excavation shall be filled with sand or other flowable aggregate.
  - (f) Installation of the liner must take place during favorable weather conditions and meet the manufacturer's specifications.
  - (g) The liner shall extend to a height above saturated soil and must be sufficiently higher than any adjacent areas where surface water may pond.
- (B) The sand media used in the filter shall be natural, washed sand with not more than five per cent passing the No. 200 (75  $\mu\text{m}$ ) sieve as determined by ASTM C117, "Test Method for Material Finer than 75  $\mu\text{m}$  (No. 200) Sieve in Mineral Aggregates by Washing." The sand must be installed to a depth of no less than 24 inches. For the purpose of this document, natural sand is defined as naturally deposited silica based sand not manufactured by mechanical processing such as crushing of rock or coarse aggregates.
- (1) Buried sand filters must use sand with an effective size of 0.5 to one millimeters and a uniformity coefficient of four or less.
  - (2) Covered sand filters shall use sand with an effective size of 0.3 to 1.0 millimeters and a uniformity coefficient of four or less.
- (C) An underdrain must be placed beneath the filter media for the purposes of collection and ultimate dispersal of effluent to the soil absorption unit.
- (1) The design shall specify the means by which the underdrain is protected from the infiltration of filter media.
  - (2) The addition of vent pipes to the underdrain will increase air flow through the filter and should be considered as part of the design. Vent pipes shall terminate above grade.
  - (3) Designs using gravel-less chamber or bundled polystyrene products to construct the underdrain shall include and follow manufacturer recommendations.
  - (4) Designs using aggregate to bed the underdrain and construct supporting layers shall meet the following specifications:

- (a) The underdrain shall be constructed with rigid perforated pipe and laid in good alignment and level. The underdrain must be installed with two layers of aggregate, herein referred to as the supporting layers.
  - (b) The underdrain shall be surrounded and covered with at least six inches of aggregate meeting the sizing requirement for coarse aggregate.
  - (c) A second, three inch layer of finer aggregate shall be washed with not more than five per cent passing the No. 200 (75  $\mu\text{m}$ ) sieve as determined by ASTM C117, "Test Method for Material Finer than 75  $\mu\text{m}$  (No. 200) Sieve in Mineral Aggregates by Washing" and shall be durable with a hardness of 3 or greater on the Moh's Scale of Hardness, meeting a sizing requirements for AASHTO M 43 sizes 7 to 8 and shall be placed over the six inch supporting layer described in paragraph (III)(C)(4)(b) of this appendix. The sand shall be placed over this supporting layer.
- (D) Sand filters shall be covered to prevent the infiltration of precipitation and surface water. The covers shall meet the following specifications:
- (1) Covered sand filters must be equipped with a manufactured cover. Filter covers must be durable, secure, insulated, and vented. An air space of no less than twelve inches must be provided between the top of the sand filter media and the cover. Cover design must allow for easy access for routine maintenance.
  - (2) Buried sand filters shall meet the following requirements:
    - (a) A geotextile filter fabric shall be installed over the gravel, chambers or expanded polystyrene bundles;
    - (b) A six inch soil cover shall be installed over the geotextile filter fabric. The soil cover shall consist of topsoil, or similar soil mixture, which allows for oxygen transfer, and is capable of supporting vegetative growth.
- (E) Sand filters shall include no less than two observation ports that extend to the interface of the sand and supporting layer. A sand filter shall also include no less than two observation ports that extend to the interface of the distribution area and sand when the surface is not exposed.
- (1) Each observation port must be placed away from points of application and shall be installed with a valve cap or plug.

- (2) Diversion collars may be installed to discourage applied effluent from short circuiting the filter along vent pipes.
  - (3) Installation of more than the minimum number of observation ports may be necessary for adequate observation of the sand surface and supporting layer surface during routine operation and maintenance for some designs.
- (F) Access, for the purposes of sampling, must be provided in the discharge line between the sand filter and the soil absorption component in accordance with paragraph (F)(1) of rule 3701-29-13 of the Administrative Code.

#### IV. Distribution Network

- (A) The design area loading rate for a timed dosed sand filter shall ensure the system remains aerobic, but shall not exceed one gallon per square foot per day. The daily design flow and design area loading rate shall be used to determine the overall dimensions of the sand filter.
- (B) Low pressure distribution with time dosing of effluent is required. All network piping and low pressure distribution piping and fittings shall be polyvinyl chloride meeting ASTM Standard D 1785 or ASTM D 2241, Schedule 13.5, 17, or 21 or equivalent. The installation of selected piping must prevent settling and damage under normal load and operating conditions. All distribution network connections shall be watertight. The design shall include the entire network configuration including pipe lengths and size, exterior control panel and alarm information, and calculations used to determine dose volume, orifice loading rates, dosing tank sizing and pump selection within the following specifications:
- (1) Distribution lines must be sized from one half to two inches in diameter. A design head of no less than five feet shall be maintained at each orifice with no more than a ten per cent difference in the operating head between the proximal and distal orifices. The system's design shall ensure a minimum fluid velocity of two feet per second is maintained in the manifold and supply piping during dosing.
  - (2) The orifice design loading rate shall not exceed one-fourth gallon per dose. Each dose shall deliver at least four times the void volume of the distribution lines to the distribution area but no greater than one-fourth the daily design flow. Orifice density shall be uniform and must result in no more than four square feet of sand per orifice with an

orifice size of no less than one-eighth inch. Orifices must be spaced a minimum of twelve inches from the edge of the sand filter.

- (3) The direction of orifices and the method of orifice shielding shall be specified in the design and shall allow for equal pressurization and depressurization of the laterals, and drain-back to prevent freezing.
  - (4) When the design uses the second compartment of a septic tank with a shared liquid level for the purposes of dosing, the pump must be contained in accordance with paragraph (J)(3) of rule 3701-29-12 of the Administrative Code.
  - (5) Controls must be installed in a location with an unobstructed view of both the sand filter and dosing tank, and a minimum of four feet above final grade.
- (C) A time-dosed sand filter design must specify how the uniform distribution of the effluent across the surface of the sand filter will be ensured.
- (1) Wastewater may be applied within a layer of coarse aggregate or bundled polystyrene above the sand media. Orifice orientation and shielding shall be specified in the design. If bundled polystyrene is to be used, the design shall include and follow manufacturer recommendations.
  - (2) If wastewater is to be sprayed upward against the top of gravel-less chambers, the design shall include and follow manufacturer recommendations.
  - (3) When orifices are positioned up in the twelve o'clock position, the effluent stream must be sprayed against an orifice shield, gravel-less chambers, or similar device. When orifices are positioned down in the six o'clock position to facilitate draining after each pump cycle, a mechanism to disperse the effluent stream such as an orifice shield, a pad of gravel, or a splash plate shall be provided.
- (D) Turn-ups and valves, for the purpose of flushing the system, must be installed at the end of each distribution line. A valve box installed to grade must be provided for each turn-up and valve.

#### V. Site Preparation and Installation

- (A) Berms, surface grading or other site modifications shall be required as necessary to keep surface water from draining into the sand filter.

- (B) Aggregate and media delivered to the site should be tested against design-sizing specifications. All aggregate and media shall be stored, loaded, transported, and installed in such a way as to avoid contamination of the material.
- (C) Filter media shall be placed in such a way as to avoid internal layering. Placing the sand by slurry or dropping the sand from a height of several feet should be avoided, because it promotes segregation by grain size.
- (D) Sand should be placed into the sand filter in six to eight one inch lifts. Each lift should be wetted and then lightly settled. Light settling may be accomplished by walking on the sand.
- (E) The filter media surface shall be level and smooth.
- (F) The buried sand filters soil cover shall be graded to discourage the ponding of surface water and seeded to promote quick vegetation growth as soon as possible after construction and inspection of the sand filter.

#### VI. Operation and Maintenance

The TDSF shall be operated, maintained, and monitored as required by the operation permit issued by the board of health. A service agreement for a pretreatment component used in a system with a TDSF shall include the maintenance and monitoring of all system components. In conjunction with any operation permit conditions or O&M provisions required by the board of health, the O&M of a TDSF shall include but is not limited to:

- (A) Checking vegetative cover for erosion or settling and any evidence of seepage on buried TDSF.
- (B) Flushing of distribution laterals.
- (C) Checking for ponding in the distribution area.
- (D) Monitoring the dose volume and operating pressure head of the distribution system.
- (E) Checking for any surface water infiltration or clear water flows from the dwelling or structures into the system components or around the TDSF.



**3701-29-14 Effluent quality standards.**

Technologies must meet the following performance based effluent quality standards as applicable to be considered for approval by the director for reductions in soil absorption area sizing, soil depth credits, nutrient reduction, or reduction of high strength waste before distribution to a soil absorption component:

- (A) CBOD<sub>5</sub>/TSS standard to use STS sizing criteria addressed in paragraph (N) of rule 3701-29-15 of the Administrative Code requires that effluent meet the mean plus one standard deviation of less than twenty-five milligrams per liter for CBOD<sub>5</sub> and thirty milligrams per liter for TSS. This standard shall apply to all pretreatment components approved or reviewed for renewal after the effective date of this chapter.
- (B) Standards that use the soil depth credits or other applicable provisions of rule 3701-29-15 of the Administrative Code require that effluent meet the geometric mean plus two standard deviations of the mean of:
  - (1) Less than or equal to ten thousand fecal coliform CFU per one hundred milliliters or 5150 *E. coli* CFU per one hundred milliliters allows for a twelve inch soil depth credit;
  - (2) Less than or equal to one thousand fecal coliform CFU per one hundred milliliter or 515 *E. coli* CFU per one hundred milliliters allows for a twenty four inch soil depth credit;
  - (3) Less than or equal to two hundred fecal coliform CFU per one hundred milliliters or 103 *E. coli* CFU per one hundred milliliters required for restricted surface application; or
  - (4) Less than or equal to twenty fecal coliform CFU per one hundred milliliters or 10 *E. coli* CFU per one hundred milliliters required for unrestricted surface application.
- (C) Nutrient reduction standards for pretreatment components may be established by the director or board of health when there is a significant risk of nutrient contamination to surface or ground water due to risk factors identified in the site review or other types of water quality assessments, or risk due to proximity to local, state, or federally recognized nutrient sensitive environments.
  - (1) When total nitrogen reduction is required, pretreatment components that meet a fifty per cent reduction in the total nitrogen concentration (average influent and effluent total nitrogen concentrations and the actual percentage of removal are provided) as demonstrated by ANSI/NSF Standard 245, BNQ Standard NQ 3680-910, CEN Standard EN 12566-3 data or equivalent shall be used.
  - (2) Other nutrients standards may be established by the director or board of health as needed for an area including higher nitrogen reduction or other nutrients.
- (D) Reduction of high strength waste standards for systems receiving sewage from a source(s) producing or expected to produce sewage of a higher strength than typical residential sewage as described in paragraph (C) of rule 3701-29-11 of the Administrative Code requires demonstration of the ability to reduce specified waste strengths to the typical residential sewage strength standard established in this chapter as determined by the director of health and sewage treatment systems technical advisory committee.

**3701-29-15 General soil absorption standards.**

- (A) Soil absorption components shall be designed to minimize the risk of exposure to sewage effluent, contamination of groundwater and surface water and provide for:
- (1) Treatment of effluent through infiltration and movement through an adequate thickness of unsaturated soil before the effluent reaches ground water or an aquifer, highly permeable materials directly connected to groundwater, flow restrictive layers, the land surface, or surface water; and
  - (2) Dispersal of treated effluent in the landscape to prevent surfacing or ponding of treated or partially treated effluent.
- (B) A STS design shall consider all site conditions identified in the soil evaluation and designs shall ensure all requirements of this rule are met.
- (C) The minimum vertical separation distance, unsaturated in situ soil, permissible effluent quality and distribution method shall be selected from paragraphs (D), (E), (F) and (G) of this rule as determined from the soil evaluation. Table 2 summarizes these requirements.

**Table 2. VSD and in situ soil requirements**

Paragraph	Limiting Condition	Minimum VSD (inches)	Minimum unsaturated in situ soil within infiltrative distance (inches)
(D)	Limiting condition not specified in this table	18	8
(E)(1)	Fractured and/or Karst bedrock	36	12
(E) (2)	Ground water or aquifer	36	12
(E) (3)	Other limiting conditions identified in soil evaluation or by the board of health as having high risk of not meeting 3701-29-15 (A)	36	12
(F)	Highly weathered soils with weak structure or low to very low permeability developed on the low lime till plains are present	24	8
(G)	Perched seasonal water if not established by board of health	12	8
(G)	Perched seasonal water as established by a board of health	6	6

- (D) Except for paragraphs (E), (F) (G) and (H) of this rule, the required minimum vertical separation distance shall be eighteen inches, and the required minimum unsaturated in situ soil thickness within the infiltrative distance shall be eight inches, to all limiting conditions.
- (E) The required minimum vertical separation distance of thirty-six inches and the required minimum in situ soil thickness of twelve inches within the infiltrative distance shall be required when the following site conditions are present:
- (1) Fractured and karst bedrock;
  - (2) Groundwater or an aquifer; or

- (3) Other limiting conditions identified in the soil evaluation or otherwise identified by the board of health as having a high risk of not meeting the requirements of paragraph (A) of this rule.
- (F) The required minimum vertical separation distance of twenty-four inches, and the required minimum in situ soil thickness of eight inches within the infiltrative distance shall be required to seasonal water table when highly weathered soils with weak structure or low to very low permeability developed on the low lime till plains are present.
- (G) Except for paragraphs (E), (F) and (H) of this rule, when a seasonal water table is present, the board of health may establish a vertical separation distance no less than six inches and no greater than eighteen inches, with a required minimum thickness of in situ soil within the infiltrative distance of no less than six inches when effluent is discharged to the soil absorption component. Unless otherwise established by the board of health, the vertical separation distance to the seasonal water table shall be twelve inches, and the required minimum thickness of in situ soil beneath the infiltrative surface shall be eight inches when effluent is discharged to the soil absorption component.
- (H) A board of health may establish the required minimum vertical separation distance of greater than zero inches and less than six inches, and the required minimum in situ soil thickness within the vertical separation distance of greater than zero inches and less than six inches where the seasonal water table is present and the sewage effluent is pretreated to less than one thousand fecal coliform CFU per one hundred milliliters. The infiltrative surface shall not be placed below the depth of the seasonal water table.
- (I) Soils defined as highly permeable materials within the infiltrative distance cannot be used to meet the vertical separation and in situ soil requirements of this rule.
- (J) When no limiting condition or flow restrictive layer is present beneath the infiltrative surface, the soil absorption component shall be placed at a depth to promote oxygen exchange and improved treatment of effluent.
- (K) The vertical separation distance required in paragraphs (D), (E), (F), (G) and (H) of this rule may be reduced using soil depth credits allowed in paragraph (L) of this rule or met through the use of an engineered drainage system to uniformly lower the level of the seasonal water table, provided the soil absorption component is installed with the required minimum in situ soil thickness and the soil depth is adequate to accept and treat all effluent from the system.
- (L) Soil depth credits for infiltrative surface elevation, pretreatment pathogen reduction, low pressure distribution and/or timed micro-dosed distribution shall be used as follows and in accordance with this chapter:
  - (1) A one-to-one equivalency soil depth credit shall apply to soil absorption components that elevate the infiltrative surface above the ground surface to meet the required VSD through the use of sand fill material as specified in appendix B to rule 3701-29-15 of the Administrative Code, or other materials as approved by the director.
  - (2) Soil depth credits shall apply for pathogen reduction by pretreatment components as authorized by the director for effluent meeting the fecal coliform treatment standards and pretreatment component requirements of rule 3701-29-14 of the Administrative Code.
  - (3) A soil depth credit of twelve inches shall apply when distribution to the soil absorption area provides for timed micro-dosing controlled at each point of application not to exceed one quarter gallon per

dose using a uniformly spaced orifice density applying no more than one gallon per four square feet of infiltrative area for each point of application per day. A soil absorption component in compliance with the requirements of appendix C to rule 3701-29-15 of the Administrative Code shall be eligible for this soil depth credit when the provisions of this paragraph are met.

- (4) A soil depth credit of six inches shall apply when low pressure distribution to the soil absorption area provides for time dosed, uniform distribution of effluent to the infiltrative surface of leaching trenches when the provisions of rule 3701-29-15.1 and Appendix A to rule 3701-29-15 of the Administrative Code are met.
- (M) Low pressure or drip distribution of effluent shall be used in accordance with this chapter, required design specifications, and as follows:
- (1) Low pressure or drip distribution shall be required when applying effluent to the sand fill infiltrative surface of a soil absorption component, or when required by the product approval.
  - (2) Low pressure or drip distribution may be required by a board of health when the site and soil conditions at the location of the proposed soil absorption component present a significant risk for the surfacing of effluent, or where effluent may reach ground water or an aquifer before adequate treatment is achieved. Conditions where a board of health may require low pressure or drip distribution shall include, but is not limited to the presence of highly permeable materials directly connected to ground water or an aquifer, shallow limiting conditions, and soils with slow to very slow permeability.
- (N) The soil absorption component area shall be of adequate size and configuration to disperse the effluent and prevent public health nuisance conditions. When determining the size and configuration of the soil absorption component area the following minimum requirements shall be met:
- (1) Soil infiltration loading rates, including basal loading rates for sand fill systems, shall be based on effluent quality and on soil structure, grade and shape, texture, and consistence and shall be determined through reference to soil evaluation information and the loading rate estimates in table 3 of this rule.
    - (a) The selection of soil loading rates based on effluent quality shall be limited to a rate for septic tank effluent or a rate for pretreated effluent meeting the CBOD<sub>5</sub> and TSS standard under rule 3701-29-14 of the Administrative Code.
    - (b) The structure, texture, structural grade and consistence of the most limiting in situ soil layer within six inches of the infiltrative surface, or basal surface if applicable, shall be used to determine a soil loading rate, unless the soil layers below the upper six inches are significantly less permeable.
    - (c) The selected soil loading rate for the site shall be used to determine the total square feet of infiltrative surface or basal area required for the soil absorption component. The daily design flow is divided by the selected soil loading rate to calculate the minimum square feet of infiltrative surface area required for soil absorption.
    - (d) When the total square feet of infiltrative surface or basal area required for a replacement system or alteration of an existing system cannot be met based on the daily design flow, the system design may allow the storage of effluent combined with time dosing and low pressure distribution to control and reduce the daily dose of effluent flow to the soil absorption area to a

daily dose flow that is less than the daily design flow. The daily dose flow to the soil absorption area is then divided by the site soil loading rate to calculate the total square feet of infiltrative surface area required for the soil absorption component. For purposes of this rule, daily dose flow means the maximum amount of effluent that can be applied to the soil absorption component based on the site and soil conditions in accordance with this chapter.

**Table 3. Soil Infiltration Loading Rates**

Soil Characteristics			Soil Infiltration Loading Rate (gpd/ft <sup>2</sup> )		
Texture	Structure		CBOD <sub>5</sub>		Row
	Shape	Grade	>25mg/L (septic tank effluent)	≤25mg/L (Pretreated effluent)	
COS, S, LCOS, LS	--	0SG	0.8	1.6	1
FS, VFS, LFS, LVFS	--	0SG	0.4	1	2
CSL, SL	--	0M	0.2	0.6	3
	PL	1	0.2	0.5	4
		2, 3	0	0	5
	PR/BK/GR	1	0.4	0.7	6
		2, 3	0.6	1	7
FSL, VFSL	--	0M	0.2	0.5	8
	PL	1, 2, 3	0	0	9
	PR/BK/GR	1	0.2	0.6	10
		2, 3	0.4	0.8	11
L	--	0M	0.2	0.5	12
	PL	1, 2, 3	0	0	13
	PR/BK/GR	1	0.4	0.6	14
		2, 3	0.6	0.8	15
SIL	--	0M	0	0.2	16
	PL	1, 2, 3	0	0	17
	PR/BK/GR	1	0.4	0.6	18
		2, 3	0.6	0.8	19
SCL, CL, SICL	--	0M	0	0	20
	PL	1, 2, 3	0	0	21
	PR/BK/GR	1	0.2	0.3	22
		2, 3	0.4	0.6	23
SC, C, SIC	--	0M	0	0	24
	PL	1, 2, 3	0	0	25
	PR/BK/GR	1	0	0	26
		2, 3	0.2	0.3	27

- (2) The HLLR shall be used to determine the minimum required length of the soil absorption component or basal area parallel to surface contours and shall be based on soil characteristics, land slope, site conditions, infiltrative distance, and the nature and depth to limiting conditions.

- (a) The HLLR shall be determined based on the soil evaluation information with reference to table 4 to determine the rate based on the soil conditions, slope and infiltrative distance.
- (b) The minimum length of the soil absorption component shall be determined by dividing the daily design flow by the hydraulic linear loading rate selected from table 4 of this rule.

**Table 4: Hydraulic Linear Loading Rate Table**

Soil Characteristics			Hydraulic Linear Loading Rate (gpd/ft)									Row
			Slope 0-4%			Slope 5-9%			Slope >10%			
Texture	Structure		Infiltrative Distance (inches)			Infiltrative Distance (inches)			Infiltrative Distance (inches)			
	Shape	Grade	8-12	12-24	24-48	8-12	12-24	24-48	8-12	12-24	24-48	
COS, S, LCOS, LS	--	OSG	4.0	5.0	6.0	5.0	6.0	7.0	6.0	7.0	8.0	1
FS, VFS, LFS, LVFS	--	OSG	3.5	4.5	5.5	4.0	5.0	6.0	5.0	6.0	7.0	2
CSL, SL	--	OM	3.0	3.5	4.0	3.6	4.1	4.6	5.0	6.0	7.0	3
	PL	1	3.0	3.5	4.0	3.6	4.1	4.6	4.0	5.0	6.0	4
		2, 3										
	PR/BK/G R	1	3.5	4.5	5.5	4.0	5.0	6.0	5.0	6.0	7.0	6
2, 3		3.5	4.5	5.5	4.0	5.0	6.0	5.0	6.0	7.0	7	
FSL, VFSL	--	OM	2.0	2.3	2.6	2.4	2.7	3.0	2.7	3.2	3.7	8
	PL	1, 2, 3										9
	PR/BK/G R	1	3.0	3.5	4.0	3.3	3.8	4.3	3.6	4.1	4.6	10
		2, 3	3.3	3.8	4.3	3.6	4.1	4.6	3.9	4.4	4.9	11
L	--	OM	2.0	2.3	2.6	2.4	2.7	3.0	2.7	3.2	3.7	12
	PL	1, 2, 3										13
	PR/BK/G R	1	3.0	3.5	4.0	3.3	3.8	4.3	3.6	4.1	4.6	14
		2, 3	3.3	3.8	4.3	3.6	4.1	4.6	3.9	4.4	4.9	15
SIL	--	OM	2.0	2.5	3.0	2.2	2.7	3.2	2.4	2.9	3.4	16
	PL	1, 2, 3										17
	PR/BK/G R	1	2.4	2.7	3.0	2.7	3.0	3.3	3.0	3.5	4.0	18
		2, 3	2.7	3.0	3.3	3.0	3.5	4.0	3.3	3.8	4.3	19
SCL, CL, SICL	--	OM										20
	PL	1, 2, 3										21
	PR/BK/G R	1	2.0	2.5	3.0	2.2	2.7	3.2	2.4	2.9	3.4	22
		2, 3	2.4	2.9	3.4	2.7	3.0	3.3	3.0	3.5	4.0	23
SC, C, SIC	--	OM										24
	PL	1, 2, 3										25
	PR/BK/G R	1										26
		2, 3	2.0	2.5	3.0	2.2	2.7	3.2	2.4	2.9	3.4	27

- (c) The soil horizon selected to determine the hydraulic linear loading rate shall also meet the following requirements and may be adjusted as follows with approval from the board of health:

- (i) The most restrictive soil horizon within the infiltrative distance shall be used to determine the HLLR;
  - (ii) Low permeability soil horizons located between the infiltrative surface and the limiting condition may be excluded from the calculation of HLLR if the cumulative thickness is less than twenty per cent of the infiltrative distance upon concurrence of the designer and the board of health.
  - (iii) Any soil horizon below the depth of the required minimum VSD may be considered to be a limiting condition when selecting the HLLR.
- (d) Adjustments to the HLLR for designs shall be considered by the designer and may be required by the board of health based on the following site conditions:
- (i) Where the infiltrative distance is less than eight inches, the HLLR may be decreased to reduce the risk of flooding of the trench bottoms, seepage at the toe of mounds or saturating the soil around drip tubing. Designs shall also consider decreasing the HLLR where the flow restrictive layer, seasonal water table or infiltrative surface is less than eight inches below the original ground surface to reduce the risk of inadequate dispersal of sewage and surfacing of effluent; or
  - (ii) When the distance to the limiting condition falls near the boundary between the columns for infiltrative distance on table 4 of this rule, designers and boards of health may choose the appropriate HLLR or modify the HLLR.
- (e) HLLR for STS designs with greater than twenty-four inches of in situ soil within the infiltrative distance may be adjusted with concurrence of the designer and the board of health as follows:
- (i) Up to two gallons per day per foot may be added to the selected HLLR value in table 4 of this rule where fractured glacial till is the uppermost limiting condition.
  - (ii) Up to three gallons per day per foot may be added to the selected HLLR value in table 4 of this rule where fractured bedrock is the uppermost limiting condition or highly permeable material is present above the limiting condition not to exceed ten gallons per day per foot.
  - (iii) Up to three gallons per day per foot may be added to the selected HLLR value in table 4 of this rule where no limiting condition is present within sixty inches of the natural ground surface.
- (f) If site and soil conditions indicate horizontal subsurface flow volumes will be greater than normal, the minimum horizontal isolation distances shall be increased in undisturbed areas around the perimeter or downslope of the soil absorption component as necessary for adequate dispersal and prevention of surface seepage.
- (g) A soil absorption component may be split into two or more portions or zones to meet the required HLLR for each portion or zone.
- (h) The calculated length along contour for soil absorption components using the linear loading rates specified in table 4 of this rule can be decreased up to ten per cent for new construction

on existing lots upon the effective date of the rules, and up to thirty per cent for replacement sites to allow installation based solely on site limitations. Where reductions in length along contour between twenty and thirty per cent are allowed, low pressure or drip distribution of effluent into the soil absorption component shall be required as specified in rule 3701-29-15.1 and appendix A, B or C to rule 3701-29-15 of the Administrative Code as applicable. Perimeter drains may also be required to facilitate subsurface drainage away from the site.

- (i) Alternative methods to determine the HLLR and length along contour may include the use of analytical solutions developed by Khan, et al. (1976), Hantush (1967), and Finnemore and Hantzsche (1983) or numerical finite element or finite difference computer models capable of simulating flow of water in saturated and unsaturated systems. The use of alternative methods shall be detailed in the system design with approval by the board of health.

(O) General requirements for designing a STS soil absorption component are as follows:

- (1) Effluent dispersal components shall be oriented parallel to natural surface contours and shall not be sited on slopes exceeding limitations specified in this chapter or applicable design manuals or product specification as referenced in accordance with this paragraph;
- (2) The use of perimeter drains, and/or an increase in the extent of fill beyond the edge of elevated shallow trenches, mounds or drip distribution systems may be required by a board of health when the flow restrictive layer is less than twelve inches from the original ground surface, the depth to seasonal water table is less than eight inches below the original ground surface, or when the infiltrative surface is less than eight inches below the original ground surface;
- (3) On sites where the installation of zones within the same system or multiple systems directly upgradient from each other on the same slope is unavoidable, there should be no less than fifty feet between soil absorption components unless ground water mounding or flow models are used to support lesser or greater separation distances. The designer and the board of health shall ensure that proper spacing and dispersal of effluent occurs in the landscape and does not create a public health nuisance;
- (4) Observation ports shall be provided to monitor the infiltrative surface of the soil absorption component as required in this chapter or approval by the director and when determined to be necessary by the board of health;
- (5) Site modification that requires the use of fill material either for soil absorption or between soil absorption components shall follow manufacturer's specifications as applicable and shall comply with the following:
  - (a) When the trench depth design results in the distribution product or media extending above natural grade of the in situ soil, fill material placed between the trenches after installation of the distribution media shall be of silt loam, loam, sand, loamy sand or sandy loam texture. Fill material shall be applied in a manner that protects and creates an interface with the underlying in situ soil and prevents compaction of material between trenches;
  - (b) Fill material applied to the natural ground surface prior to the excavation of leaching trenches for the purpose of creating trench sidewall shall be sand, loamy sand, or sandy loam texture soil capable of maintaining trench sidewall stability during installation and shall be applied in a manner that both protects and creates an interface with the underlying in situ soil; and



- (c) Unless evaluated as suitable, fill material shall not be present in the vertical separation distance below the infiltrative surface of soil absorption components. Careful consideration shall be given prior to siting soil absorption components in settled non-compacted fill material including but not limited to strip mine spoils to determine the development of pedogenic features and its suitability for soil absorption. Over time, fill material may develop the characteristics of soil; however, it shall be thoroughly evaluated for such characteristics, in addition to treatment and dispersal capacities;
  - (6) Designs shall prevent damage to components or operational failures due to freezing temperatures; and
  - (7) The STS design for a soil absorption component may include referenced design manuals, proprietary soil absorption component specifications including those for gravelless and chamber products, or alternative aggregate product specifications provided these do not conflict with this chapter. Unless an available internet source for any referenced manual or specification is included in a STS design, the design manual, proprietary soil absorption component specifications, or alternative aggregate product specifications shall accompany the plan. Inclusion of referenced resources does not substitute for critical information or calculations required for board of health approval of a STS design.
- (P) Installation shall be conducted by a registered installer in a manner consistent with an approved STS design to assure proper operation and future servicing or monitoring of the soil absorption component.
- (1) Areas designated for installation and replacement shall be undisturbed and be protected from damage or disturbance. If any disturbance or damage has occurred, installation shall not proceed and the registered installer shall contact the owner, designer, and the board of health.
  - (2) Soil moisture conditions shall be evaluated at the time of installation throughout the soil absorption area. The excavation or preparation of the soil infiltration interface, such as a trench or basal area, shall not proceed when there is a risk of smearing, compaction, or clogging of pore spaces as demonstrated by any of the following:
    - (a) A wire test in the field where the soil crumbles when rolled between the palms of the hands before a wire one-eighth inch in diameter can be formed;
    - (b) When the moisture content is less than the plastic limit as established in ASTM standard D4318; or
    - (c) Other means established by the board of health.
  - (3) Proprietary soil absorption components or alternative aggregate product specified in an approved STS design shall be installed in accordance with the manufacturer's installation instructions or product specifications and the approved STS design provided these do not conflict with this chapter.
  - (4) Baseline records including but not limited to system startup reports, and any soil absorption component O&M instructions shall be provided by the installer to both the owner and the board of health as a condition of installation approval.

- (Q) STS soil absorption components shall be operated, maintained, and monitored as required by the operation permit issued by the board of health to assure compliance with the requirements of this chapter.
- (R) A board of health may not issue a variance to paragraphs (E) and (H) of this rule.

**3701-29-15.1 Low pressure distribution.**

- (A) The low pressure distribution design shall include the entire network configuration including, but not limited to, pipe lengths and size, exterior control panel and alarm information, and calculations used to determine dose volume, orifice flow rates, dosing tank sizing and pump selection within the following specifications:
- (1) Distribution Network
    - (a) Supply network piping including the main, sub-mains, and manifold shall be watertight, rigid solid wall pipe, and shall be properly supported to prevent sagging and damage under normal loads and operating conditions. All network piping and low pressure distribution piping and fittings shall be polyvinyl chloride meeting ASTM Standard D 1785 Schedule 40, 80, or 120 or ASTM D 2241, SDR 13.5, 17, or 21 or equivalent. All fittings shall be pressure rated meeting or exceeding ASTM D 2466.
    - (b) Manifold designs shall address freeze protection while assuring uniform distribution. The manifold shall be designed to minimize drain down of laterals into other laterals at a lower elevation between dosing events.
    - (c) Lateral pipes shall be three-quarter to two inches in diameter.
    - (d) There shall be no more than a ten per cent difference in flow rate between the proximal and distal orifices on each distribution lateral. The system design shall ensure a minimum fluid velocity of two feet per second is maintained in the main and manifold piping during dosing.
    - (e) There shall be no more than a fifteen per cent difference in the flow rate between two orifices in different distribution laterals that are to be dosed simultaneously during a single dosing event.
    - (f) Laterals shall include valves to allow adjustment of the operating distal pressure at startup to meet design specifications in compliance with this standard. The distal operating pressure of each lateral shall be adjusted at startup to ensure compliance with this rule. Baseline measurements including reconciling the gallons per minute with the design, distal pressures/heights, and dose rates for future O&M and monitoring must be measured and recorded before STS approval by the board of health.
    - (g) Low pressure distribution networks shall have an accessible means of measuring design pressure or operating head for both initial baseline measurement and future monitoring of orifice clogging and other network operations and shall include a means of scouring or flushing distribution laterals.
  - (2) Dose Frequency and Volume
    - (a) Except when the flow restrictive layer is present within twelve inches of the natural ground surface, each dose shall deliver to the distribution area no greater than one-fourth of the daily design flow and at least five times the void volume of the laterals during each twenty-four hour period. When a flow restrictive layer is present within twelve inches of the natural ground surface, each dose shall deliver no greater than one-eighth of the daily design flow and at least three times the void volume of the laterals during each twenty-four hour period. The board of health may require time dosing for the design to maximize treatment by control of the instantaneous loading rate and dose frequency. For split mounds and zoned low pressure distribution leaching, the dosing frequency shall be equal for each zone within a twenty-four

hour period. The dosing volume shall be based on the soil loading rate for each mound or zone.

- (b) When time dosing is used, the selected dose volume and frequency shall ensure that dosing events are spaced uniformly throughout a twenty-four hour period to maximize resting between dosing events. Time dosed controls should prevent premature dosing when less than the daily dose volume is present in the dosing tank.
- (3) Orifices and Orifice Shielding
- (a) Orifices shall be uniform, clean, and free of all drill cuttings. Lateral pipes must be stabilized when drilling orifices to prevent the pipes from moving and to ensure orifices are drilled perpendicular to the pipe.
  - (b) Orifices must be sized no less than one-eighth inch and spaced a maximum of six feet apart along the lateral.
  - (c) The orifice number and spacing shall provide distribution of no more than six square feet per orifice with an orifice size of not less than one-eighth inch. Orifices must be spaced a minimum of six inches from the end of the lateral.
  - (d) The direction of orifices and the method of orifice shielding shall be specified in the design and shall allow for uniform pressurization and depressurization of the laterals, and drain-back to prevent freezing.
  - (e) The design must specify how the effluent stream from the orifices will be dispersed for uniform distribution. When orifices are positioned up in the twelve o'clock position, the effluent stream must be sprayed against an orifice shield, gravel-less chambers, or similar device. When orifices are positioned down in the six o'clock position to facilitate draining after each dosing cycle, a mechanism to disperse the effluent stream such as an orifice shield, a pad of gravel, or a splash plate shall be provided.
  - (f) When orifice shields are used, they must be strong enough to withstand the weight of the backfill and large enough to protect the orifice from being plugged by gravel.
  - (g) If effluent is to be sprayed upward against the top of gravel-less chambers, the design shall include and follow manufacturer recommendations.
- (4) The selected distal pressure to be maintained at the end of each lateral shall be no less than three feet when using three-sixteenth inch or larger diameter orifices, and no less than five feet when using orifices smaller than three-sixteenth inch.
- (5) Pressure dosed STS shall use either elapsed time meters, event counters, or flow meters capable of measuring total flow to help determine flow rates and dose volumes. Time dosed STS shall also have control panels with programmable timers, manual pump operation or hand-off-auto switches, test features, and as applicable, adjustable override settings. Adjustable override settings cannot exceed the daily design flow and the override volume cannot exceed the dosing design of the downstream component.
- (6) Dosing tanks and pumps and controls must meet the design and sizing specifications of rule 3701-29-12 of the Administrative Code. The dosing tank size and the pump, exterior control panel, and alarm information shall be included with the design. The design shall indicate the settings or means used to accommodate the dose volume including any drainback to the dosing tank.

- (7) Testing, setting, adjusting and recording of any low pressure distribution components and control panel functions shall be conducted prior to installation approval by the board of health. Flow rate and distal pressure or operating head shall be consistent with STS design specifications and a baseline shall be recorded for future performance monitoring.
  - (8) O&M and monitoring devices
    - (a) Inspection ports shall be installed to comply with the following:
      - (i) Pressure distributed leach trenches shall have at least one inspection port placed in each leaching trench for observation of distribution and any ponding at the infiltrative surface. The ports shall be anchored and be accessible with at least a four inch opening and a removable cap; and
      - (ii) Mounds shall have at least three inspection ports spaced at intervals adequate for observation of distribution and any ponding at the sand fill infiltrative surface. The ports shall be anchored and be accessible with at least a four inch opening and a removable cap.
    - (b) Accessible turn-ups shall be provided at the end of each lateral for the purpose of flushing the laterals and testing distal operating head.
    - (c) Shutoff mechanisms with a durable and stable access port shall be provided to isolate portions of the distribution network.
- (B) Sewage treatment systems using low pressure distribution shall be operated, maintained, and monitored as required by the operation permit issued by the board of health. The O&M and monitoring of the entire STS shall be conducted at least annually, or more often as required by a condition of the operation permit. A service agreement for a STS with a pretreatment component shall also include the maintenance and monitoring of all system components. In conjunction with any operation permit conditions or O&M provisions required by the board of health, the O&M of a sewage treatment system utilizing low pressure distribution shall include but is not limited to:
- (1) Checking for ponding in the distribution area;
  - (2) Checking for surface water infiltration or clear water flows from the dwelling or structures into the system components and around or onto the soil absorption area;
  - (3) Checking the vegetative cover for erosion or settling and any evidence of settling or seepage in the area of the soil absorption component;
  - (4) Monitoring for proper operation of mechanical devices;
  - (5) Monitoring the dose volume and operating pressure head of the distribution system and compare to baseline measurements;
  - (6) Flushing of distribution laterals; and
  - (7) Review and document event counters, elapsed time meters, flow meters, and alarm conditions where present.

3701-29-15

## APPENDIX A

## Technical Standards for Use of Leaching Trenches for Soil Absorption

## I. Introduction

All soil absorption components and technologies shall be designed and installed to meet the requirements of rule 3701-29-15 of the Administrative Code for soil absorption. This appendix establishes the minimum standards for leach trenches to be used for dispersal of sewage effluent from approved septic tanks, pre-treatment components, or GWRS.

## II. Limitations and Conditions for Use

- (A) Trenches shall be oriented parallel to natural surface contours and shall be sited to avoid natural drainage features and depressions that may hold surface water. A variation of plus or minus three inches along the surface contour may be permissible to accommodate trench installation along the contour.
- (B) STS designs shall address surface water diversion as needed. An interceptor drain may be installed upslope of the leaching trench soil absorption component to intercept horizontal flow of subsurface water to reduce its impact on the down gradient leaching trenches in accordance with rule 3701-29-16 of the Administrative Code.
- (C) Special safety considerations and installation criteria as needed are required for installing trenches on a slope greater than fifteen per cent. Manufacturer prohibitions and instructions shall be followed. When the depth to a limiting condition requires the approved distribution media or product to be installed to within six inches of or above natural grade, and fill material is placed between and/or over trenches for the purpose of creating trench sidewall, soil cover installation on slopes greater than fifteen per cent may not be feasible due to the risk of material slippage and maintenance of appropriate trench depths.

## III. Leaching Trench Design

- (A) The leaching trench bottom area shall be of adequate size and configuration to disperse the effluent and prevent surface seepage and shall comply with the sizing requirements within rule 3701-29-15 of the Administrative Code.

- (1) The total leaching trench infiltrative surface area shall be calculated using the soil loading rate from table 3 of rule 3701-29-15 of the Administrative Code and the daily design flow. Unless timed low pressure distribution is used, additional leaching trench infiltrative surface area, for the purpose of resting portions of the leach field, shall be added to the calculated soil absorption component area in all leaching systems. The additional area shall be no less than twenty-five per cent of the required minimum area under this rule. When resting any portion of the soil absorption system, the daily design flow to the trenches in use shall not exceed the design soil loading rate.
  - (2) The minimum leaching trench infiltrative surface area permitted for approved leaching trench products using a non-gravel, fines-free distribution system shall be no less than seventy-five per cent of the required area calculated using table 3 of rule 3701-29-15 of the Administrative Code.
  - (3) When multiple technologies that are approved for soil absorption area sizing reduction are used in a system (i.e. pretreatment plus gravel-less leaching), only one sizing reduction can be applied to the system.
- (B) The daily design flow and linear loading rate will establish the minimum length of trenches along each contour. Partial trenches that do not provide the required length along contour are not permitted. Leach trench lengths exceeding one hundred fifty feet, as a result of lineal loading rate calculations, are permissible. The manifold shall be placed in the center for trenches longer than one hundred fifty feet. Use of low pressure distribution in systems with trenches longer than one hundred fifty feet may be considered.
- (C) Leaching trenches for new sewage treatment system installations shall have a maximum width of two feet. Leaching trenches may be up to three feet wide for system alteration or replacements when two-foot wide trenches will cause installation of a soil absorption component other than leaching trenches when leaching trenches would otherwise be authorized, or the installation of a leaching trench configuration that is disadvantageous for the proper dispersal of the effluent. The minimum length as determined in accordance with table 4 of rule 3709-29-15 of the Administrative Code and the specified trench width shall be used to determine the number of leaching trenches needed to accommodate the daily design flow. Approved leaching trench products using a non-gravel, fines-free distribution system shall have a minimum projected product width that substantially fills the trench to within two inches.

- (D) Trench depth shall be determined by the limiting condition and have a minimum depth of two inches into the in situ soil across the entire bottom width of the trench. A leaching trench bottom shall be as level as practicable along its length and shall be installed in accordance with the guidelines set forth in this appendix.
- (E) The space between trench walls of adjacent trenches shall be no less than four feet for gravity distributed trenches, and no less than three feet between trenches when using low pressure distribution. Trench spacing of no less than two feet between trenches may be used when using low pressure distribution where soils have coarse to loamy sands, and fine to loamy very fine sand textures found on lines one and two of table 3 of rule 3701-29-15 of the Administrative Code.

#### IV. Distribution Network and Media

- (A) Trench distribution media shall consist of one of the following:
  - (1) Coarse aggregate having a minimum thickness of eight inches with a minimum of two inches of coarse aggregate above and below the distribution pipe;
  - (2) Approved chamber or bundled polystyrene distribution media products having a minimum eight inch height used in accordance with manufacturer specifications for installation; or
  - (3) Other alternative distribution media materials as authorized by the department of health.
- (B) A geotextile fabric, straw covering, or other barrier as specified for proprietary products shall be used to prevent the introduction of soil fines into the distribution media and shall allow for free movement of air and water. The soil cover shall have a depth of at least six inches after settling or greater if specified for a proprietary product and shall be of a quality to allow for oxygen transfer and growth of vegetation.
- (C) Distribution pipe used in leaching trenches with gravity distribution shall extend the entire length of the trench shall be a minimum of three inches in diameter and meet ASTM D1785, ASTM D2729, ASTM F405, or ASTM F810 standards. Distribution pipes must have at least one row of holes of no less than one-half inch in diameter or equivalent area, spaced no more than forty inches apart.



- (D) The low pressure distribution network for a pressure dosed system shall be designed and installed in accordance with rule 3701-29-15.1 of the Administrative Code.
- (E) Effluent distribution devices, including distribution boxes, flow dividers, and flow diversion devices shall be:
  - (1) Structurally sound and watertight to prevent infiltration of surface and ground water;
  - (2) Placed level on a solid foundation of soil, concrete, or sand to prevent differential settlement of the device;
  - (3) Backfilled in a manner to minimize migration of effluent between trenches; and
  - (4) Have sufficient size openings to allow access for maintenance.
- (F) Alternative dosing and distribution methods when gravity flow is not possible or preferred are allowed. Serial distribution of effluent, as defined in rule 3701-29-01 of the Administrative Code, is prohibited. STS designs shall specify the means of distribution and management requirements, including but not limited to:
  - (1) Specification of either parallel or sequential distribution using devices with access to grade and mechanism for flow diversion for the sequential resting of each trench in the soil absorption component.
  - (2) Distribution device connections between the tank or another distribution device, and to a leaching trench, shall be watertight and shall include properly supported, solid pipe meeting ASTM D1785, ASTM D2729, or ASTM F810 standards to prevent settling and damage under normal loads and operating conditions. The material used to backfill or bed the piping shall not allow sewage or effluent to bypass the piping for distribution service.
  - (3) A means for determining the liquid level or capacity of each leaching trench shall be provided. If an inspection port is used or required by the local board of health, the port shall be anchored and accessible with at least a two inch opening and a removable watertight cap.
  - (4) For short term repairs or resting of leaching trenches, easily accessible shut-off mechanisms shall be provided to allow for segregation of flows to each trench.

- (5) References or specifications for dosing or distribution methods, such as lift tanks, flood dosing, surge and reserve capacity for timed dosing, or low pressure distribution.

#### V. Operation and Maintenance

(A) A leaching trench system shall be operated, maintained, and monitored as required by the operation permit issued by the board of health. For sewage treatment systems where a pretreatment component precedes a leaching trench, any service agreement for the pretreatment component shall include the maintenance and monitoring of all system components. In conjunction with any operation permit conditions or O&M provisions required by the board of health, the O&M of a trench soil absorption system may include but is not limited to:

- (1) Monitoring the liquid level or capacity of the leaching trench soil absorption component;
- (2) Management of flow diversion mechanisms for the purpose of resting portions of the soil absorption area;
- (3) Checking for surface water infiltration or clear water flows from the dwelling or structures into the system or onto the soil absorption area;
- (4) Monitoring for proper operation of mechanical components and/or distribution methods, as applicable;
- (5) Checking surface grade for vegetative cover, erosion or settling, and any seepage in the area of the soil absorption component; and
- (6) Any other O&M requirements specified by the manufacturer of the system.

(B) When leaching trenches use low pressure distribution, the system O&M requirements shall include:

- (1) Monitoring the dose volume and operating pressure head of the distribution system and compare to baseline measurements.
- (2) Pressure distributed leaching trenches shall be inspected at a frequency of at least once a year. Inspection shall include flushing of distribution laterals.
- (3) Review and document event counters, elapsed time meters, flow meters, and alarm condition where present.

3701-29-15

## APPENDIX B Sand Mound

### I. Introduction

All soil absorption components and technologies shall be designed and installed to meet the requirements of rule 3701-29-15 of the Administrative Code for soil absorption. This appendix establishes the minimum standards for a sand mound to be used for dispersal of sewage effluent from approved septic tanks or pre-treatment components

### II. Limitations and Conditions for Use

- (A) Sand mounds shall be sited to allow for the vertical separation distances specified in rule 3701-29-15 of the Administrative Code.
- (B) The basal area of the mound shall be oriented parallel to natural surface contours and shall be sited to avoid natural drainage features and depressions that may hold surface water or otherwise impact the installation or functionality of the mound. A design for a mound shall address surface water diversion as needed.
- (C) An interceptor drain or perimeter drain in compliance with paragraphs (C) and (D) of rule 3701-29-16 of the Administrative Code may be used when determined to be necessary by the board of health, soil evaluator, or system designer.
- (D) Sites with boulders or numerous trees are less desirable for a mound soil absorption component. Such conditions shall be avoided, when possible, or the design shall increase the basal area to compensate for losses due to boulders or flush cut trees and shall include special instructions for the basal area preparation under such conditions.

### III. Sand Mound Design

- (A) The design shall include the calculations used for determining the distribution area width and length and the basal area width and length including any variation due to slope and the subsequent increase in sand fill depth. The design may include references to mound resource manuals.
  - (1) The basal area of the mound shall be calculated using the soil loading rate from table 3 of rule 3701-29-15 of the Administrative Code and

the daily design flow. The minimum length along contour shall be calculated using the linear loading rate from table 4 of rule 3701-29-15 of the Administrative Code and the daily design flow.

- (B) In addition to the basal area, the area downslope from the mound for slopes greater than five per cent, or a radial area surrounding the mound for slopes less than five per cent as appropriate for the site, shall be free of any site disturbances.
- (C) The mound sand fill depth shall be determined based on the depth to the limiting conditions. The sand fill depth shall not be less than four inches for effluent from a pretreatment component approved by the director for meeting the BOD<sub>5</sub> and TSS standard and six inches for septic tank effluent. The loading rate for the sand fill material shall not exceed one gallon per day per square-foot. For the purpose of this rule, natural sand is defined as naturally deposited silica based sand not manufactured by mechanical processing such as the crushing of rock or coarse aggregates. The mound sand fill shall be a natural sand meeting one the following:
  - (1) Sand specifications in the Ohio State University Mound Bulletin (2004).
  - (2) Sand meeting the gradation requirements of ASTM C33, provided not more than five per cent passes the No. 200 (75 µm) sieve as determined by ASTM C117, "Test Method for Material Finer than 75-µm (No. 200) Sieve in Mineral Aggregates by Washing".
  - (3) Having an effective size between 0.15 to 0.3 millimeters, a uniformity coefficient of 5 or less, with not more than five per cent passing the No. 200 (75 µm) sieve as determined by ASTM C117, "Test Method for Material Finer than 75-µm (No. 200) Sieve in Mineral Aggregates by Washing" and not less than eighty per cent passing the No. 8 (2.36mm) sieve.
- (D) A geotextile fabric or straw covering of the aggregate in the distribution area or other barrier as specified for proprietary components shall be used to prevent introduction of soil fines and allow for free movement of air and water.
- (E) The soil cover shall be applied to allow for an approximate depth of six inches after settling, and the mound shall be crowned to promote runoff. Soil cover shall be of a quality to allow for oxygen transfer and growth of vegetation.

#### IV. Distribution Network and Media

- (A) The distribution network of the mound shall be designed in accordance with rule 3701-29-15.1 of the Administrative Code. The design shall include the entire distribution network configuration, including pipe lengths and sizes for the force main, any force main branches, manifolds, laterals with orifice size, spacing, and shielding, and the calculations used to determine the dose volume and pump selection.
- (B) Mound distribution media shall consist of one of the following:
  - (1) A minimum of three inches of approved coarse aggregate placed beneath the distribution pipe and at least one inch of approved coarse aggregate placed over top of the pipe;
  - (2) Approved chamber or bundled polystyrene distribution media products having a minimum eight inch height used in accordance with manufacturer specifications for installation; or
  - (3) Other alternative distribution media materials as authorized by the department of health.

#### V. Site Preparation and Installation

The mound shall be installed in accordance with Chapter 3701-29 of the Administrative Code, the installation permit, the approved design, any referenced resource and the following:

- (A) If any site disturbance or damage has occurred, installation shall not proceed and the registered installer shall contact the owner and the board of health.
- (B) Prior to installation, the registered installer shall check all elevations in the design relative to the established benchmark including the surface contour and the flow line elevation of other components to assure proper flow through the system and freeze protection, as applicable.
- (C) Soil moisture conditions shall be evaluated and basal area preparation shall not proceed when there is risk of smearing or compaction of soil.
- (D) All vegetation shall be cut close to the ground and removed from the site. Removal of stumps, roots, sod, topsoil, and boulders shall be limited to minimize basal area compaction and disturbance.

- (E) The force main should be installed from the upslope side. All vehicle traffic on the basal area and downslope area of the mound should be avoided with installation work being conducted from the upslope side or end of the mound basal area.
- (F) The basal area of the mound shall be prepared to create a sand/soil interface to increase infiltration. The basal area preparation shall not reduce the infiltrative capacity of the soil surface. The degree of basal area preparation shall be determined on a site by site basis depending on soil conditions but shall not extend deeper than the topsoil. Any basal scarification or other basal area preparation shall be conducted working along the contour. Sand may be incorporated into the basal area during the preparation process. Following basal preparation, a layer of sand fill shall be placed on the entire basal area to prevent damage from precipitation and foot traffic.
- (G) The specified depth and sufficient amount of sand fill shall be placed to cover the basal area, and shall not be steeper than three to one side slopes. The distribution area shall be formed to the specified dimensions and the sand surface of the distribution area shall be level.
- (H) The area around the mound system shall be protected from erosion through upslope surface water diversion and provision of suitable vegetative cover, mulching, or other specified means of protection.
- (I) Installer documentation shall include, but not be limited to, the measured height of the distal operating head, the system flow rate, and dose volume settings as baseline measures for future O&M and monitoring. Documentation shall be provided to the board of health to be included in the permit record.

## VI. Operation and Maintenance

The mound system shall be operated, maintained, and monitored as required by the operation permit issued by the board of health. A service agreement for a mound system with a pretreatment component shall also include the maintenance and monitoring of all system components. In conjunction with any operation permit conditions or O&M provisions required by the board of health, the O&M of a mound soil absorption system shall include but is not limited to:

- (A) Checking the mound for vegetative cover, erosion or settling, and any evidence of seepage on the sides or toes of the mound;
- (B) Flushing of distribution laterals;

- (C) Checking for ponding in the distribution area;
- (D) Monitoring the dose volume and operating pressure head of the distribution system;
- (E) Checking for any surface water infiltration or clear water flows from the dwelling or structures into the system components or around the mound soil absorption area; and
- (F) Review and document event counters, elapsed time meters, flow meters, and alarm conditions, where present.

3701-29-15

## APPENDIX C Drip Distribution Systems

### I. Introduction

All soil absorption components and technologies shall be designed and installed to meet the requirements of rule 3701-29-15 of the Administrative Code for soil absorption. This appendix establishes the minimum standards for drip distribution systems to be used for dispersal of sewage effluent from approved septic tanks, pre-treatment components.

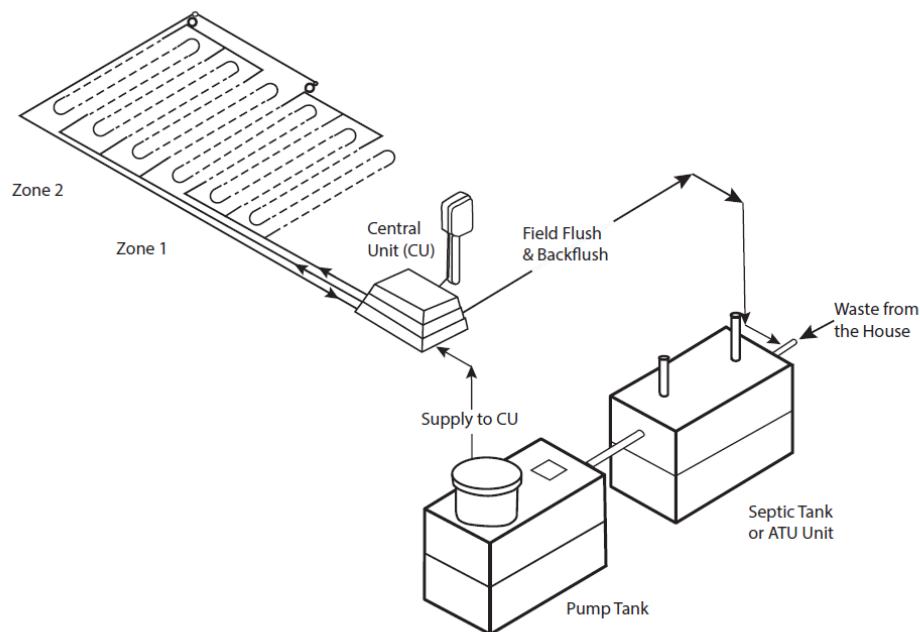

**Figure 9. Drip Distribution System**

### II. Drip Assurance

Any person intending to provide a fully supported drip distribution STS shall submit written assurances of compliance to ODH for approval. In addition to the written assurances, a submittal shall include sample designs, manuals for the drip distribution and other STS components as applicable, and any other information required in the drip distribution assurances application. Any changes proposed after the originally approved assurance package must be approved by the Ohio Department of Health.



- (A) The written assurances shall indicate how the responsible party demonstrates compliance with the following:
- (1) Assure that the site and soil conditions and limitations reported for each site represent accurate information and that the designs comply with those site and soil conditions and limitations.
  - (2) Assure that designs comply with the conditions, specifications, and other provisions set forth in this chapter.
  - (3) Assure the provision of training to installers and oversight as necessary to assure proper installation.
  - (4) Assure that upon completion of an installation, a system start-up is conducted to establish baseline performance and compliance with design specifications.
  - (5) Assure that more than one qualified service provider is reasonably available to system owners to conduct O&M requirements for the entire system through service contract provisions. The drip assurance party may choose to train the system owner to be the service provider for that system only. This does not preclude the system owner from meeting the requirements for registration as a service provider in rule 3701-29-03 of the Administrative Code. Forms, programs, or instructions supporting start-up procedures and O&M service and monitoring shall be provided with the written assurances.
  - (6) The department may audit any drip assurance party, drip distribution installations and associated service providers.

### III. Site Limitations and Conditions for Use

- (A) Drip distribution systems shall be oriented and installed parallel to natural surface contours and shall be sited to avoid natural drainage features and depressions that may hold surface water
- (B) Drip distribution designs shall address surface water diversion as needed. An interceptor drain in accordance with rule 3701-29-16 of the Administrative Code may be used upslope of the drip distribution components to intercept the horizontal flow of subsurface water to reduce its impact on the down gradient drip distribution absorption area.
- (C) Drip distribution systems may be installed on a slope greater than twenty-five per cent with special safety consideration and installation criteria as needed.

#### IV. Drip Distribution Design

- (A) The method and calculations for sizing the soil absorption area in accordance with rule 3701-29-15 of the Administrative Code shall be included in the design with reference to any manufacturer, supplier, or designer specifications but shall not be less than that determined in accordance with the soil evaluation information or the maximum loading rate allowable for use of the timed micro-dosing distribution soil depth credit.
- (B) Drip distribution areas shall be sited, and the drip tubing installed, parallel to natural surface contours.
- (C) The design shall specify that any disturbance or damage in the drip distribution or replacement areas may result in the invalidation of the design.
- (D) The design shall indicate the vertical separation distance from the drip tubing to limiting conditions and justify the placement of the drip tubing at a specific subsurface depth not to exceed one foot, at-grade, or a specific sand fill elevation. Placement of the drip tubing greater than one foot in depth shall only be permitted when unique site conditions are present, and the designer can justify in the design that all other conditions (i.e. loading rates, vertical separation, timed micro-dosing rates) can be met.
- (E) The drip tubing shall be spaced to ensure that SILR and HLLR are met.
- (F) Drip tubing spacing may range from six inches to two feet on center when placed on sand fill that meets one of the following specifications:
  - (1) Sand meeting the gradation requirements of ASTM C33, provided not more than five per cent passes the No. 200 (75  $\mu$ m) sieve as determined by ASTM C117, "Test Method for Material Finer than 75- $\mu$ m (No. 200) Sieve in Mineral Aggregates by Washing".
  - (2) Having an effective size between 0.15 to 0.3 millimeters, a uniformity coefficient of 5 or less, with not more than five per cent passing the No. 200 (75  $\mu$ m) sieve as determined by ASTM C117, "Test Method for Material Finer than 75- $\mu$ m (No. 200) Sieve in Mineral Aggregates by Washing" and not less than eighty per cent passing the No. 8 (2.36mm) sieve.

- (G) Cover material and depth specifications including precautions for freeze protection of the entire distribution system shall be included in the design.
- (H) Any selected pretreatment component shall meet the STS design specifications including additional capacity if needed to accommodate added flow from field flushes. Use of pretreatment to justify reductions in either the soil absorption area or vertical separation distance shall be specified in the design.
- (I) Only pressure compensating emitters shall be used for STS drip distribution. The design shall specify the flow rate of the emitters and approximate absorption area per emitter.
- (J) Dosing controls shall prevent flow to the drip distribution component in excess of the daily design flow. Controls shall provide a means to record alarm events, troubleshoot system malfunctions, and monitor flow over time and flow rates during both dosing and flushing events including the use of a flow meter to monitor system operation.
- (K) Drip tubing shall be maintained through an automated scouring flush at a frequency adequate to prevent coating of the drip tubing and clogging of emitters. The frequency shall be specified in the design and shall not be less than twice a month per zone under normal operating conditions and shall be adjustable for actual operating conditions.
- (L) Drip tubing flushes and filters flushes used to reduce solids going to emitters shall be returned to the influent end of the pretreatment component or septic tank. In the case where flush volumes may disrupt the process of a septic tank or pretreatment component, added capacity shall be required.
- (M) For management purposes, at least two zones shall be included in the drip distribution design, with an easily accessible shutoff mechanism for each zone. The timed micro-doses may be applied simultaneously or alternately to each zone.
- (N) Air release valves are required at the highest elevation in each zone to vent the zone and prevent soil fines from entering the emitters during drain down after the pump shuts off.
- (O) The design shall specify how to minimize gravity redistribution after dosing.

## V. Site Preparation and Installation

The installation of drip distributed systems shall comply with these rules, any permit issued by the board of health, and the following:

- (A) All vegetation shall be cut close to the ground and removed from the site
- (B) Soil moisture conditions shall be evaluated and basal area preparation shall not proceed when there is risk of smearing or compaction of soil.
- (C) When drip tubing is placed at-grade or on sand fill, the basal area preparation shall be specified in the design. The basal area preparation shall not reduce the infiltrative capacity of the soil surface. The degree of basal area preparation shall be determined on a site-by-site basis depending on the soil conditions but shall not extend deeper than the topsoil. Any basal scarification or other basal area preparation shall be conducted working along the contour. Sand may be incorporated into the basal area during the preparation process. Following basal area preparation, a layer of sand fill shall be placed on the entire basal area to prevent damage from precipitation and foot traffic.
- (D) Following installation and before STS approval by the board of health, the responsible party and/or the registered installer shall conduct a start-up procedure and document baseline measurements needed for future O&M and monitoring. Baseline measurements and monitoring information shall include but is not limited to dose rates and flushing flow rates for each zone and calculation of daily flow averages.
- (E) Alarm event instructions shall be readily accessible at alarm panel.

## VI. Operation and Maintenance

- (A) In conjunction with O&M management requirements, and as a condition of an installation and operation permit for a drip distribution STS, the board of health shall require the owner of a drip distribution STS to maintain an O&M service contract.
- (B) The O&M and monitoring of the entire STS shall be conducted at least annually, or more often as required by the responsible party or the manufacturer of any component of the drip distribution STS, and shall be conducted by the responsible party or by a service provider who has been qualified by the responsible party.
- (C) O&M records shall be submitted to the board of health.

**3701-29-16 Site drainage.**

- (A) When siting a STS, existing drain tile, or other artificial subsurface drainage present on the lot shall comply with the following:
- (1) Shall be avoided whenever possible and shall maintain at least eight feet of horizontal separation from the soil absorption component of a STS;
  - (2) Existing drainage tile that intersects the soil absorption area shall be rerouted where possible. When tile is re-routed, the abandoned section of tile shall either be plugged with bentonite, cement or concrete, or removed to at least ten feet from the soil absorption component of the sewage treatment system, or broken up in place to prevent movement of water;
  - (3) Where existing sites may have close drain spacing and removal of the drainage is not practical, the design shall prevent migration of effluent to the drain; and
  - (4) Existing drainage on the lot may be used if necessary to facilitate drainage as long as isolation distances and VSDs are met.
- (B) When surface water runoff will infiltrate or cause ponding in, on or around STS components, diversion swales or other grading shall be designed to intercept and divert surface water with specifications indicated in the design plan. STS components shall not be sited in depressions or concave topographic features where surface water runoff cannot be properly managed through diversion. Diversion of surface water associated with a STS shall not negatively impact drainage of or onto other properties or storm water management.
- (C) An interceptor drain shall be sited no closer than six feet upslope of a soil absorption component, and shall prevent effluent from entering the interceptor drain. The specifications for the interceptor drain shall comply with paragraphs (D) and (E) of this rule, and shall be included in the design plan.
- (D) A perimeter drain intended to create a gradient to improve the drainage of a site with seasonal saturation or an engineered drainage system designed in accordance with appendix A to this rule shall meet the following:
- (1) Be sited no closer than six feet on the upslope side of the soil absorption component and eight feet from the outermost extent of the other sides of the soil absorption component and shall not cross any portion of the soil absorption component;
  - (2) Where a flow restrictive layer is present, the bottom elevation of the perimeter drain must be installed no deeper than two inches into the flow restrictive horizon except when the bottom elevation must be deeper to allow for proper drainage at the outfall;
  - (3) The bottom elevation of the perimeter drain shall maintain sufficient vertical distance between the bottom of the perimeter drain, and the bottom of the soil absorption component to induce flow to the drain;
  - (4) Be designed and constructed to ensure subsurface flow of water to the drain;
  - (5) Be limited to sites with at least six inches of unsaturated soil beneath the bottom of the infiltrative surface of the soil absorption component of the STS unless the STS design uses a pretreatment component approved for meeting the one-thousand fecal coliform CFU per one hundred milliliters standard prior to dispersal to the soil; and

- (6) Be sited not less than eight feet from a mound lateral or one foot from the toe of the mound.
- (E) Subsurface drainage shall comply with the following:
- (1) The drainage pipe shall be slotted pipe four inches in diameter;
  - (2) Drainage pipe wrapped with a geotextile fabric shall not be used when the soil has a silt content greater than forty per cent;
  - (3) The subsurface drain trench shall have a positive slope of at least one-tenth foot per one hundred feet;
  - (4) The drainage pipe shall be backfilled with a minimum of ten inches of coarse aggregate. As determined by the designer or the local board of health, a subsurface drain trench may be backfilled to final grade or to within six inches of final grade with coarse aggregate, and the final six inches, if applicable, to final grade with cover soil material. When ground water can develop velocities sufficient to move sand or silt or both into the drain, filter or drain envelopes may be required in lieu of the coarse aggregate envelope. Filter or drain envelopes must be able to restrict the movement of sand and/or silt into the drain pipe so that the hydraulic capacity of the drain pipe is maintained. Filter or drain envelopes should be installed according to the manufacturers specifications, or in accordance with part 650, chapter 14 of the NRCS, national engineering handbook; and
  - (5) The subsurface drain trench and the associated discharge piping shall be designed to have water flow by gravity from the drain when possible.
- (F) Engineered drainage shall be designed in accordance with appendix A to this rule to lower seasonal saturation in the soil across the soil absorption area throughout the year to provide a sufficient thickness of unsaturated soil to meet the vertical separation distance requirements. Engineered drains shall meet the following requirements:
- (1) Water discharged from engineered drainage systems shall not create a public health nuisance as defined in section 3718.011 of the Revised Code;
  - (2) Engineered drainage systems shall be properly installed and maintained to ensure consistent operation during the life of the STS;
  - (3) A STS design that proposes to use an engineered drainage system shall identify the depth to the seasonal water table with no drainage and the depth to which the seasonal water table will be lowered with drainage to demonstrate that the vertical separation distance required is met; and
  - (4) The engineered drainage design shall demonstrate that the proposed drain spacing and depth can lower the seasonal water table to the desired depth to achieve a thickness of unsaturated soil to meet the vertical separation distance required at least three hundred and thirty days each year, with no more than thirty days of continuous saturation above the desired depth, at a recurrence frequency of thirty per cent (an average of at least nine years in thirty).
- (G) A drainage outlet for interceptor, perimeter, or engineered drain shall comply with the following:
- (1) The drainage outlet must be accessible, include rigid solid wall pipe and animal guard, and shall be designed to allow for free flow from the invert of the pipe for the purpose of sampling. Where the drainage outlet is not accessible a sampling port may be required;

- (2) The drainage outlet shall be designed and installed to prevent clogging by siltation or vegetative growth and accessibility shall be maintained for cleaning;
- (3) The drainage outlet must have sufficient freeboard above typical annual maximum flow to ensure the drain flows in all seasons. The invert of the pipe for a gravity flow outlet shall be at least four inches above the water level of the receiving stream or ground surface, whichever is closer;
- (4) If a gravity flow outlet cannot be achieved the drain shall include a pump vault accessible for sampling and of sufficient size and dose volume to maximize pump life. A pumped drain may include a check valve and an alarm in compliance with paragraph (M) of rule 3701-29-12 of the Administrative Code;
- (5) The receiving area for a drainage outlet shall not pond and shall allow free flow away from the outlet during both dry and wet weather conditions to an established drainage feature. Drainage designs may need to consider other models for surface water drainage for the area; and
- (6) Written permission shall be obtained from the owner, agency, or other controlling entity for placement of a drain outlet within a right-of-way or legally established public drainage improvement. A drain outlet associated with a STS shall be subject to the easement provisions of paragraph (G) of rule 3701-29-06 of the Administrative Code.

3701-29-16

APPENDIX A  
Drainage to Manage the Level of Seasonal Water in Soils

## I. Introduction

The design, installation and maintenance of engineered drainage systems shall comply with the requirements of rule 3701-29-16 of the Administrative Code and this appendix. Engineered drainage systems consist of uniformly spaced drains placed at a depth to lower seasonal saturation in the soil throughout the year to provide a sufficient thickness of unsaturated soil to meet the vertical separation distance requirements at a site. Engineered drainage systems can be designed using analytical solutions with confirmation monitoring or computer simulation models to determine the drain configuration to achieve the amount of drawdown of the seasonal water table required.

## II. Siting Limitations and Conditions for use

- (A) Engineered drainage systems may be designed and installed on sites where analytical models with confirmation monitoring or computer simulation models demonstrate that the drainage systems can lower the seasonal water table the minimum number of days each year to the depth necessary to provide a thickness of unsaturated soil beneath the soil absorption area to meet the vertical separation distances required.
- (B) The design and performance of the engineered drainage system must meet the specifications of paragraphs (E) and (F) of rule 3701-29-16 of the Administrative Code.

## III. Engineered drainage system design options.

- (A) Analytical solution with confirmation monitoring procedure. A system owner may present a design plan for constructing an engineered drainage system based on an analytical solution combined with water level monitoring during periods of typically high soil water elevations over a period of time to demonstrate the drawdown achieved by using the following procedures and interpretation method:
  - (1) The proposed STS design shall include the design plan and specifications of the engineered drainage system using an analytical solution including but not limited to the ellipse equation or Hooghoudt's modification of the ellipse equation as defined in Chapters 4 of Section 16, NRCS National Engineering Handbook



(1971), Chapter 14 of Part 650, NRCS National Engineering Handbook (2001), or other equivalent drainage calculations.

- (2) The design plan shall include the supporting engineering calculations of drain spacing and drawdown, the methodology and process to monitor water surface elevations by submitting a design that includes a soil evaluation, the monitoring well location, well and soil profile at each proposed monitoring location, and a monitoring plan.
- (3) The design plan shall include the materials, drainage construction specifications and layout of the engineered drainage system.
- (4) The monitoring plan shall include:
  - (a) The proposed number, installation depth, screening depth, soil and well profile, materials and installation procedures for each monitoring well, and proposed method of measurement.
  - (b) A minimum of three water level monitoring wells shall be installed for water surface observation at each site.
  - (c) Monitoring well locations shall include portions of the soil absorption areas containing the most limiting soil/site conditions.
  - (d) Monitoring wells shall extend at least four feet below the natural soil surface, or to the top of the limiting condition, whichever is shallower.
  - (e) Additional monitoring wells shall be required for sites handling systems with a design flow greater than six-hundred gallons per day with a minimum of one additional monitoring well per six hundred gallons per day increment.
- (5) Local conditions may require the evaluation of the proposed loading rates from the STS as part of the direct monitoring procedures as determined by the designer or the board of health.
- (6) Measurements of seasonal saturation in the soil and rainfall monitoring shall be conducted under the responsible charge of a third-party consultant with assistance by the property owner or the owner's agent. A third party consultant is qualified when registered as a professional engineer in the state of Ohio, American Institute of Professional Geologists certified professional geologist, or Soil Science Society of America certified soil scientist. The property owner may collect the measurements under the supervision of the third-party

consultant. The property owner shall submit the name(s) of the consultant(s) performing any monitoring on their behalf to the board of health.

- (7) The water surface in the monitoring wells shall be recorded at least daily from January 1 to April 30, taken at the same time during the day plus or minus three hours. An on-site rain gauge is required within one-half mile of the site. At least daily rainfall shall be recorded beginning no later than December 1 through April 30. National Weather Service or Ohio Department of Natural Resources, Division of Soil and Water Resources rainfall data may be used in lieu of an on-site rain gauge if available within ten miles of the site. If rainfall for the monitoring period differs by more than twenty-five per cent of normal rainfall for the area based on National Weather Service records, then additional monitoring for a longer period of time may be required.
  - (8) The interpretation of the well monitoring data, precipitation and drainage drawdown and probability determinations of drainage performance will follow guidance prepared by the department or standards of practice as described in the NRCS National Engineering Handbook.
- (B) Computer simulation models. Two and three dimensional computer simulation models may be used to design an engineered drainage system for a site and predict the performance of the system. The computer model must be capable of simulating a water balance for the soil profile including infiltration of precipitation, evapotranspiration, and drainage and provide a prediction for seasonal water table levels in the soil. Computer simulation models may include but are not limited to DRAINMOD, HYDRUS2 or other computer simulation models approved by the director.
- (1) The depth to seasonal saturation with engineered drainage installed may be determined by application of computer simulation models to predict daily water levels over at least a thirty year historic time period. The output of results from the model shall be used to evaluate where the seasonal saturation in the soil horizon is present based on a proposed drainage modification to the site.
    - (a) The seasonal saturation in the soil with drainage modifications shall be determined as the highest level predicted by the model to be saturated for thirty day continuous period annually with a recurrence frequency of thirty per cent.

- (b) Drainage modifications to a site must successfully achieve no less than the elevation, duration of days of saturation, and the frequency of occurrence as cited above and as required in rule 3701-29-16 of the Administrative Code.
- (c) For sites designed to receive over six-hundred gallons per day, the computer simulation model shall take into consideration the impact of effluent application on the projected water table surface. Local conditions may require the evaluation of the proposed loading rates from the STS as part of the modeling procedures as determined by the designer or the board of health.
- (d) The ground water simulation analysis shall be prepared and submitted to the board of health by individuals that can demonstrate competency in the use of the computer simulation models by training and experience and who are registered professional engineers in Ohio, American Institute of Professional Geologists certified professional geologist, Soil Science Society of America certified soil scientist, or other individuals approved by the department.
- (e) Data inputs for the computer simulation models shall follow all applicable requirements of the user's guide for the model including, but not limited to long term precipitation data, soil and site data most applicable to the conditions determined at the site being modeled, hydraulic conductivity of each soil horizon, depth and spacing of proposed drainage features and surface storage and drainage parameters.
- (f) A sensitivity analysis shall be performed to evaluate the range of soil and site characteristics for choosing input parameters related to the soil profiles, hydraulic conductivity input values based upon the range of hydraulic conductivity values measured on the site, and inputs for surface and subsurface drainage features based on the range of possible elevations and distances that occur or may occur after installation of improvements. The sensitivity analysis shall establish which parameters are most critical for determination of the depth to soil wetness condition. Conservative values for the most critical parameters shall be used in applying the model to the site.

**3701-29-17 Gray water recycling systems and alternative toilets.**

- (A) Gray water recycling systems shall include type 1, type 2, type 3 and type 4 systems as described in paragraphs (E), (F), and (G) of this rule and may receive gray water generated from a building or dwelling.
- (B) A board of health may issue a permit for the design and installation of a type 1 GWRS. Except for gray water systems installed for campgrounds under Chapter 3729. of the Revised Code, a board of health shall issue a permit in compliance with rule 3701-29-09 of the Administrative Code for type 2, 3 and 4 GWRS. When a GWRS is proposed at the same time as a new or replacement STS, both systems shall be authorized under the same permit. Designs for GWRS shall meet the requirements of rule 3701-29-10 of the Administrative Code as applicable.
- (C) The definition of public health nuisance in section 3718.011 of the Revised Code shall apply to GWRS.
- (D) GWRS shall meet the following requirements:
  - (1) Gray water discharged to all GWRS shall only consist of domestic type flows having the consistency and strength typical of gray water from domestic households. The source of gray water may include water from bathing, showering, washing clothes or laundry sinks. Gray water shall not contain water used to wash diapers, or other materials soiled with human excreta or infectious materials, or wastewater that has come in contact with toilet waste, toxic substances, cleaning chemicals other than soap, water softener backwash or any other hazardous household products;
  - (2) Design flows to GWRS shall be determined based on the flow rate of the fixture(s) or the discharge volume from the appliance(s) intended for discharge to the system;
  - (3) The isolation distance requirements of paragraph (G)(3) of rule 3701-29-06 of the Administrative Code;
  - (4) Shall be used and contained within the property boundary of the building it originates from unless a legally recorded easement permits access to and application on another property;
  - (5) Type 1, 2, or 4 GWRS shall include a readily accessible diversion valve in the sewage line from the dwelling or building so all the gray water can be directed into the STS or the approved public sewer system when necessary. The diversion valve must be visibly labeled;
  - (6) All pipes conveying gray water must be labeled with the following words in capital letters: "Caution: Non-potable water, do not drink" or the pipe shall be purple or purple striped in color;
  - (7) If a type 1, 2 or 4 GWRS fails or is suspected of failing, the owner shall immediately divert the gray water to the approved public sewer system or STS serving the dwelling or structure;
  - (8) The gray water system owner shall maintain a record of the GWRS that includes the location of the system, identifies the fixture(s) that are the source of the gray water, describes the system design and maintenance requirements, and includes the calculation of the total minimum irrigation area required;
  - (9) The system owner shall ensure that the GWRS is properly operated and maintained; and
  - (10) Except for type 3 GWRS, no reduction in the design and sizing of the STS shall be permitted when using a GWRS. All other sewage from a dwelling or structure shall be discharged to an approved STS or sanitary sewer.

(E) Type 1 and type 2 GWRS shall meet the following requirements:

- (1) Type 1 and type 2 GWRS shall only be used for subsurface irrigation during the normal growing season in Ohio as described in this paragraph and may be used for subsurface irrigation of gardens, lawns and landscape plants, and food crops except root crops or crops that have edible portions that contact the gray water. Gray water shall be applied no less than twenty-five feet from food crops with exposed edible portions;
- (2) A type 1 GWRS shall discharge no more than sixty gallons per day. A type 2 GWRS shall discharge greater than sixty gallons per day but no more than one-thousand gallons per day;
- (3) Shall use durable piping, tubing, or flexible hoses to disperse the water below the surface of the ground by gravity. During or after dispersal to the soil, gray water shall not surface in any way, including through ponding or runoff, and must remain below the surface of the ground to prevent contact with people and animals;
- (4) Shall be covered by a minimum of four inches of appropriate material which may include suitable soil or other material such as mulch, humus, or compost. If material other than suitable soil is used, the irrigation field cover must be augmented periodically as needed to maintain adequate cover during the growing season;
- (5) For type 1 GWRS, the system owner may direct gray water to separate irrigation fields as long as the total flow of gray water to all fields combined does not exceed sixty gallons per day;
- (6) For a type 1 GWRS, the total minimum irrigation area available to receive the gray water must be adequate based on the soil infiltration rate, the evapotranspiration rate, and the water requirements of the plants or area being irrigated. A type 2 GWRS system shall require a soil evaluation as specified in rule 3701-29-07 of the Administrative Code to determine the soil infiltration loading rate and the presence of limiting conditions. A type 2 GWRS shall require a design that determines the total irrigation area based on the daily design flow of the system, irrigation rates that are dependent on the plant use, evapotranspiration rates, soil infiltration rates, and hydraulic linear loading rates as applicable;
- (7) Shall be located in suitable soil that is not saturated during the growing season, and where at least twelve inches of vertical separation distance is maintained above the limiting conditions listed in paragraph (E) of rule 3701-29-15 of the Administrative Code;
- (8) Shall not be applied to slopes exceeding twenty per cent or discharged to frozen or saturated soils; and
- (9) No gray water may be held in a tank or holding structure more than twenty-four hours.

(F) Type 3 GWRS shall meet the following requirements:

- (1) A soil evaluation shall be completed to determine the soil infiltration loading rate and the presence of limiting conditions;
- (2) The column specifying pretreated effluent in table 3 of rule 3701-29-15 of the Administrative Code shall be used to determine the soil infiltration loading rate, and shall be provided a twelve inch soil depth credit for meeting the vertical separation distance specified in rule 3701-29-15 of the Administrative Code;

- (3) A type 3 GWRS shall be designed in accordance with rule 3701-29-15 of the Administrative Code and appendix A to rule 3701-29-15 of the Administrative Code;
  - (4) A type 3 GWRS may be designed for continual use and shall not exceed a daily design flow of one thousand gallons per day;
  - (5) Tanks used with type 3 GWRS must be structurally sound and watertight; and
  - (6) Hand-carried gray water may be poured into a gray water disposal sump that is connected to the soil absorption component of the system. The gray water disposal sump must include a receiving chamber with a screen. Hand-carried gray water may also be poured into a structure fitted to the top opening of a septic tank provided the structure connection to the septic tank is sealed and watertight.
- (G) Type 4 GWRS shall meet the following requirements:
- (1) A type 4 GWRS may be used for surface and subsurface irrigation of gardens, lawns and landscape plants, food crops, green roofs and living walls during the normal growing season in Ohio or as applicable for the irrigation application. When surface irrigation of gray water is used, signs shall be posted to notify the public and personnel within the use area that the water used is gray water and is not safe for drinking;
  - (2) The system shall include a pretreatment component or treatment train that meets NSF/ANSI Standard 350 treatment level R or C as appropriate for the design and gray water source or equivalent that is approved by the director and in compliance with rule 3701-29-13 of the Administrative Code;
  - (3) Durable piping, tubing, or flexible hoses to disperse the water at or below the surface of the ground by gravity or low pressure distribution shall be used. During or after dispersal to the soil, gray water shall not pond or runoff;
  - (4) A subsurface type 4 GWRS shall be covered by a minimum of four inches of appropriate material which may include suitable soil or other material such as mulch, humus, or compost. If material other than suitable soil is used, the irrigation field cover must be augmented periodically as needed to maintain adequate cover during the growing season;
  - (5) A type 4 GWRS shall discharge greater than sixty gallons per day but no more than one thousand gallons per day. Gray water may be stored for more than twenty-four hours with pretreatment;
  - (6) A soil evaluation as specified in rule 3701-29-07 of the Administrative Code shall be required to determine the soil infiltration loading rate and the presence of limiting conditions as applicable;
  - (7) A type 4 GWRS shall require a design that determines the total irrigation area based on the daily design flow of the system, irrigation rates that are dependent on the plant use, evapotranspiration rates, soil infiltration rates, and hydraulic linear loading rates as applicable;
  - (8) A type 4 GWRS shall be located in suitable soil that is not saturated during the growing season, and where at least twelve inches of vertical separation distance is maintained above the limiting conditions listed in paragraph (E) of rule 3701-29-15 of the Administrative Code;
  - (9) A type 4 GWRS shall not be applied to slopes exceeding twenty per cent or discharged to frozen or saturated soils; and

- (10) Except for tank size, tanks, pumps and controls required as part of a type 4 GWRS design must comply with the requirements of rule 3701-29-12 of the Administrative Code. Tank sizing shall be determined based on the design and proposed irrigation rates of the system.
- (H) Composting and incinerating toilets are STS components and may be used for the disposal and treatment of toilet waste including human excreta and urine.
- (I) A STS that uses composting or incinerating toilets for disposal and treatment of toilet waste must discharge all other sewage from the dwelling or building including but not limited to water from kitchen sinks, dishwashers, clothes washing, bathing or showering, bathroom or laundry sinks to a STS.
- (J) A STS using composting or incinerating toilets for disposal and treatment of all toilet waste in the dwelling may reduce the daily design flow to the STS by up to twenty-five per cent as determined by the designer, homeowner and the board of health.
- (K) Composting toilets used as part of a STS must be certified to ANSI/NSF Standard 41 and are authorized for use. A manufacturer of a composting toilet that is not certified to ANSI/NSF Standard 41 who seeks approval for use in the state must submit an application in accordance with the requirements of section 3718.04 of the Revised Code and obtain approval for use from the director of health.
- (L) Incinerating toilets used as part of a STS must be certified to NSF Protocol P157 and are authorized for use. A manufacturer of a incinerating toilet that is not certified to NSF Protocol P157 who seeks approval for use in the state must submit an application in accordance with the requirements of section 3718.04 of the Revised Code and obtain approval for use from the director of health. Electrical connections for incinerating toilets must comply with the requirements of the national electric code.
- (M) All plumbing connecting a composting or incinerating toilet to the building sewer must comply with the Ohio plumbing code or applicable local building codes and requirements.
- (N) Composting or incinerating toilets authorized for use under paragraph (K) or (L) of this rule shall be installed and vented in accordance with the manufacturer's specifications or as authorized by the director's approval.
- (O) Liquid and solid materials removed from a composting toilet shall be disposed of as septage in accordance with rule 3701-29-20 of the Administrative Code. Dry incinerated waste material from an incinerating toilet shall be disposed of at a solid waste landfill permitted by Ohio EPA.

**3701-29-18 Privies, holding tanks, and portable toilets.**

- (A) A holding tank or privy shall only be installed by a registered installer when authorized and permitted by the board of health in compliance with this chapter.
- (B) A privy shall only be permitted and installed as a HSTS under the following limited conditions:
  - (1) All plumbing or drain connections to the privy are prohibited;
  - (2) The privy shall comply with the requirements of paragraph (A) of rule 3701-29-12 of the Administrative Code and shall have a capacity of not less than five hundred gallons;
  - (3) Except for unoccupied buildings, the location of the privy shall comply with all isolation distance requirements in paragraph (G)(3) of rule 3701-29-06 of the Administrative Code; and
  - (4) The superstructure shall be vented and minimize entry of insects, animals or surface water.
- (C) A holding tank permitted as a HSTS shall meet the following specifications when a variance has been granted by the board of health:
  - (1) For temporary abatement of a public health nuisance for an existing system;
  - (2) The site with the holding tank shall be placed into an O&M monitoring program;
  - (3) A holding tank shall comply with the tank requirements of rule 3701-29-12 of the Administrative Code;
  - (4) A holding tank shall be located to meet the isolation distance requirements of the rules and shall be easily accessible for frequent pumping;
  - (5) The size of the holding tank shall take into account the design flow criteria established in rule. The board of health shall establish a required frequency of pumping for the tank or require the installation of a high water alarm in compliance with this rule as a condition of the variance; and
  - (6) On a temporary basis during inclement weather and/or during the non-installation season when the property owner must take occupancy until soil conditions are suitable for complete system installation.
- (D) Portable toilets and portable sewage tanks shall be constructed to be watertight and structurally sound, prevent spillage during transport, and provide access for removal of the contents. For purposes of this rule, portable toilets and portable sewage tanks also include type III marine sanitation devices.
- (E) A board of health that has taken responsibility for SFOSTS shall not permit a holding tank for a SFOSTS. Except as permitted for HSTS in accordance with this paragraph, holding tanks are subject to the requirements of Ohio EPA under rule 3745-42-11 of the Administrative Code.
- (F) The owner of a privy, holding tank, portable toilet, portable sewage tanks, or type III marine sanitation device shall have a registered septage hauler remove the contents of the vault or tank before the capacity is exceeded.
- (G) As a condition of the operation permit required in paragraph (I) of rule 3701-29-09 of the Administrative Code, the board of health shall require the contents of a privy or holding tank be removed in accordance with this rule and in compliance with any other installation permit, operation permit or variance conditions established by the board of health.



**3701-29-19 STS Operation and maintenance management, and system owner education.**

- (A) The board of health shall develop a program for the administration of O&M management for STS and GWRS and system owner education in compliance with division (A)(7) of section 3718.02 of the Revised Code and this chapter.
- (1) O&M management and system owner education is required for all systems installed or altered after the effective date of this chapter.
  - (2) Boards of health shall work with interested stakeholders to develop a timeline and process for phasing in O&M management for prior installed systems and should consider risk factors such as system age, complexity and risks to public health when establishing the criteria and process for phasing in prior installed systems, except as provided in paragraph (B) of this rule.
  - (3) All STS that have been issued coverage under the general household NPDES permit after January 1, 2007 shall be included in the O&M management program.
- (B) Boards of health that have established a program prior to the effective date of this chapter for the monitoring or assessment of systems, are authorized to continue their program provided that the program allows a person to demonstrate the required maintenance of a system in lieu of a board of health inspection. Monitoring and assessment of STS may also be performed upon request for real estate inspections or as part of locally established real estate transfer programs.
- (C) An O&M management program shall include but is not limited to the provisions of this rule and any additional provisions of an O&M management program established by the board of health shall not be considered as more stringent standards subject to division (B) of section 3718.02 of the Revised Code. O&M management programs shall include the following minimum components:
- (1) Permit records organized by location providing a history of siting, design, installation, alteration, operation, monitoring, maintenance, and abandonment activities. The results of any O&M monitoring, service contracts, sampling, inspections or reporting required by this chapter shall be maintained in the permit record. All records and information regarding a system's operation and maintenance shall be provided to the board of health within sixty days of any operation and maintenance inspection.
  - (2) Demonstration of board of health and STS or GWRS owner compliance with operation permit requirements for system types as required in this chapter.
  - (3) Tracking of activities and requirements associated with the conditions of an operation permit or this chapter, including but not limited to:
    - (a) Dates and results of any inspections or maintenance service including the inspection required in paragraph (H) of rule 3701-29-09 of the Administrative Code.
    - (b) Time lines for the expiration and renewal of an operation permit as applicable.
    - (c) Record of owner compliance with the service contract or other maintenance requirements in accordance with this chapter and the operation permit conditions established in paragraph (I) of rule 3701-29-09 of the Administrative Code;
    - (d) Record of any related enforcement activities;
    - (e) Record of any water quality or other samples collected from the system; and

- (f) A service provider or board of health may use electronic monitoring and tracking of system operation and maintenance.
- (D) O&M in accordance with manufacturer's instructions shall be met when required as a condition of an operation permit, as part of a STS or GWRS product approval, or as otherwise required in this chapter. A person may demonstrate the required O&M of their system in lieu of having a board of health inspection conducted when an inspection is otherwise required. This may include a person securing a service contract or being certified for O&M service by a manufacturer. The board of health shall advise the owner of the ability to demonstrate required O&M through the use of a service contract or owner certification. The owner shall provide proof of servicing and maintenance appropriate to the STS or GWRS to the board of health that includes, but is not limited to:
- (1) A copy of the system service report that is signed and dated by a registered service provider or owner who is certified by the manufacturer to service the installed STS or GWRS. Service providers shall notify the board of health when service contracts are not renewed;
  - (2) Service reports must include minimum information as required by the department for a specific technology or product, the board of health, and the manufacturer as applicable for every component of the system. Service checklists that provide a comprehensive listing of the minimum service requirements shall be used when applicable or available for a product or system type;
  - (3) Provide a copy of septic tank pumping receipts, tank and distribution box inspections, and cleaning of effluent filters as applicable; and
  - (4) Any other information that demonstrates maintenance of the system as required by the operation permit.

This shall not preclude the board of health from conducting compliance inspections for the purpose of oversight of installers, service providers or septage haulers nor from requiring payment of an operation permit fee for O&M management.

- (E) Owners of HSTS that have obtained coverage under the household general NPDES permit shall comply with the following O&M requirements:
- (1) Obtain effluent samples for monitoring as required by the household general NPDES Permit. Effluent samples shall either be collected by the board of health, or if allowed by the board of health, a registered service provider in accordance with protocols established by the department or Ohio EPA. Effluent samples shall be collected in accordance with rule 3701-29-13 of the Administrative Code or as approved by the director from either the installed sampling port or the point of discharge for the STS installation;
  - (2) Maintenance, repair, servicing or alteration of the system as required to meet the action limits established by Ohio EPA when system effluent quality exceeds the limits established in the household general NPDES permit or more often as necessary to meet the action limits; and
  - (3) Owners of HSTS that have obtained coverage under the household general NPDES permit, and are not consistently able to meet the effluent quality standards, shall work with the system manufacturer and the board of health to take steps necessary to bring the system into compliance with the established limits, and may include, but is not limited to, the installation of an approved tertiary component or additional approved treatment devices as approved by the department of health, or alteration or limitations on the quantity or quality of sewage discharged into the system.

- (F) A board of health may establish a household sewage treatment district in accordance with division (A)(14) of section 3718.02 of the Revised Code and the following minimum criteria and procedures:
- (1) A household sewage treatment district established by a board of health shall provide a responsive approach to prevent or resolve sewage treatment problems from HSTS within an established district;
  - (2) When establishing a household sewage treatment district the board of health shall by formal resolution provide in writing the authority, purpose, scope, and details of the district management program including any fees;
  - (3) In advance of the adoption of a resolution establishing a household sewage treatment district, the board of health shall provide public notice in a newspaper of general circulation and shall inform all affected homeowners by mail at least ninety days in advance of the adoption of the resolution; and
  - (4) The board of health may enter into a contract with any entity to administer a household sewage treatment district management program.
- (G) The board of health shall promote compliance with this chapter through educational outreach including but not limited to the following:
- (1) Providing information to STS owners on the type of STS they own and how it functions, and how to manage, maintain and care for their STS to ensure proper system performance and sustainability.
  - (2) Help ensure that the STS owner is provided with O&M instructions and service reporting requirements.
  - (3) Provide information to system owners on how to access the department of health and manufacturer internet sites for O&M instructions as required by division (F) of section 3718.05 of the Revised Code, or upon written request, directly provide a copy of these O&M instructions.
- (H) The board of health may provide owners with information on financial assistance resources, and may promote or participate in local and state financial assistance programs to support STS repair and replacement or connection to sanitary sewers and STS abandonment including, but not limited to, the following:
- (1) Complete a HSTS management plan to access state revolving loan funds.
  - (2) Establish a local revolving or low interest loan program.
  - (3) Encourage targeted community development funding.

**3701-29-20 Septage and sewage management.**

- (A) The board of health shall assess the management of STS septage and sewage generated within its jurisdiction, including adequate capacity for the disposal of STS septage and sewage and/or land application of domestic septage within the area of its jurisdiction. The board of health may adopt rules prohibiting, restricting or limiting the land application of septage within its jurisdiction.
- (B) Septage and sewage management by the board of health shall include, but is not limited to, the following:
- (1) Notification to septage haulers registered by the board of health of wastewater treatment plants that are authorized to accept septage or other available receiving locations for STS septage and sewage, if known.
  - (2) The evaluation and permitting of septage application sites and any prohibitions on the land application of domestic septage. Compliance with this rule and 40 C.F.R. 503 is required when land application is permitted by the board of health.
  - (3) Provision of information to STS owners on recommended time lines for removal of septage from STS components including more frequent removal when a garbage disposal is in use.
  - (4) Requirements for reporting of septage and/or sewage removal or pumping from septic tanks, pretreatment components, dosing tanks, holding tanks for dwellings, campers, recreational vehicles, marinas or other temporary uses, or portable toilets as applicable when required as a condition of an operation permit or as necessary to demonstrate compliance with this chapter.
- (C) Septage haulers shall maintain a record and manifest of septage or sewage pumped from each STS including, but not limited to, the system owner; location address; quantity of septage or sewage removed from the system; condition of tank; presence or absence of baffles or tees; condition of risers; evidence of high water, water intrusion, or tank deterioration; any repairs, replacements or improvements made to the tank; date of septage or sewage removal; and the wastewater treatment plant or other receiving facility where the septage or sewage was disposed, or the location of land application. Pumping and disposal records shall be provided to the board of health on a form prescribed by the director and retained by the septage hauler for at least five years. The septage hauler shall provide a receipt to the system owner showing the date of service, any conditions noted regarding the tank, risers and effluent filters, and quantity of septage and sewage removed from the system.
- (D) Septage haulers shall comply with the following requirements when removing sewage from septic tanks, pretreatment components, dosing tanks, lift stations, holding tanks for dwellings, campers, recreational vehicles, marinas or other temporary uses, or portable toilets:
- (1) Sewage and septage contained in septic tanks, dosing tanks, pretreatment tanks, holding tanks for dwellings, campers, recreational vehicles, marinas or portable toilets shall be pumped or removed as practicable until the tank is empty. The septage hauler must evaluate the need for refilling tanks that have been pumped with water to prevent tank flotation;
  - (2) Baffles and tees shall be inspected if present, and their condition or absence thereof be reported to the system owner;
  - (3) Effluent filters if present shall be cleaned;
  - (4) Pretreatment components and dosing tanks shall be pumped in accordance with the manufacturer's directions;
  - (5) Lift stations shall be cleaned and hosed down so that no septage is left in the tank;

- (6) All means of preventing spillage of sewage or septage onto the surface of the ground should be used during or upon completion of pumping. If spillage occurs, it must be properly cleaned and the area disinfected; and
  - (7) Other solid materials removed from a STS, including but not limited to, filter media, peat, or other components containing septage or effluent, shall be dewatered as necessary and taken to a solid waste disposal facility licensed by the Ohio EPA.
- (E) No person shall apply domestic septage to a site without a septage land application site permit issued by the board of health.
- (1) Any person requesting a septage application permit shall submit:
    - (a) The completed application and associated fee;
    - (b) Site documentation to support compliance with the requirements of this rule;
    - (c) Written permission from the property owner to land apply septage and information on the presence of any field tile, ditches, storm sewer systems, streams, or other drainage conveyances within the proposed land application site;
    - (d) Information from an order two soil survey indicating that the site has a slope no greater than eight per cent, has at least three feet of soil above ground water and bedrock, and is free of conditions that could allow land application of septage to cause contamination of ground water or run off to surface waters; and
    - (e) Any additional information required by the board of health including documentation concerning the site and surrounding area, or documentation of the land application methods used by the registered septage hauler.
  - (2) The board of health shall conduct a site inspection prior to approval and shall enforce the prohibitions in this paragraph. Land application of domestic septage is prohibited within the sanitary isolation radius of a public water system well as determined in accordance with rule 3745-09-04 of the Administrative Code. Land application of domestic septage is also prohibited within an inner management zone of a drinking water source protection area determined to be highly susceptible to contamination by the Ohio EPA source water protection and assessment program for a community or non-transient non-community public water system as defined in rule 3745-81-01 of the Administrative Code. The area to be used for land application shall meet the following minimum horizontal isolation distances:
    - (a) Two hundred feet from any dwelling, business, or location used for community gatherings or recreational purposes;
    - (b) Fifty feet from any property line;
    - (c) One hundred feet from any private water system, non-potable water well or water supply well used by a transient, non-community public water system as defined in rule 3745-81-01 of the Administrative Code;
    - (d) Fifty feet from any waters of the state excluding ground water but including grass waterways;
    - (e) Three hundred feet from a sinkhole or drainage well, or one hundred feet if a permanent vegetative buffer is maintained around the sinkhole or drainage well; and

- (f) One thousand five hundred feet from a public drinking water surface water intake.
  - (3) When considering an application for a land application site permit, the board of health shall review the submitted documentation and the site conditions.
  - (4) The board of health may deny the approval of a land application site permit if there are substantial changes to site conditions or the site review application information and may require re-application including a fee to reapply.
  - (5) The board of health may specify permit terms and conditions governing the application of septage, unless such terms and conditions conflict with Chapter 3718. of the Revised Code, this chapter or 40 C.F.R. 503.
  - (6) An approved land application site permit issued by the board of health shall be valid for one year from the date of issuance.
  - (7) An approved land application site permit may be revoked by the board of health prior to its expiration if there is a change in site conditions, or there is evidence of noncompliance with Chapter 3718. of the Revised Code, this chapter, or 40 C.F.R. 503.
- (F) Land application of domestic septage shall not create a public health nuisance and shall be performed for agronomic benefit in compliance with this paragraph and 40 C.F.R. 503 on sites permitted and approved by the board of health.
- (1) A land application permit in compliance with this rule shall be obtained from the board of health prior to land application of septage.
  - (2) The amount of septage applied to the site shall not exceed the annual nitrogen application rate required for the type of vegetation on the site. The soil shall be tested every two years for phosphorus and shall not exceed the recommended levels for agronomic loading rates. Any vegetation or crop grown on the application site shall be harvested, grazed, or otherwise removed in accordance with 40 C.F.R. 503.
  - (3) Trash shall be screened and removed from the septage prior to land application and the trash shall be dewatered prior to disposal as solid waste.
  - (4) Septage shall be land applied in accordance with the following:
    - (a) Septage shall not be permitted to pool or flow on the surface of the ground.
    - (b) Septage shall be applied in accordance with the vector attraction reduction requirements and the pathogen reduction requirements of 40 C.F.R. 503.
  - (5) Records shall be maintained by the septage hauler for at least five years to demonstrate compliance with this rule and the requirements of 40 C.F.R. 503.

**3701-29-21 STS abandonment.**

- (A) A STS or applicable component of a STS shall be disconnected from the dwelling and properly abandoned when it is no longer in use due to connection to sanitary sewer, system replacement, the existence of a physical hazard or public health nuisance, change in the use of the lot, or as otherwise ordered by a board of health unless otherwise authorized by the board of health in compliance with paragraph (B) of this rule.
- (B) The board of health having jurisdiction for a STS that is no longer used for sewage treatment may allow the STS or a portion of the STS to remain on the lot, provided the system is disconnected from the dwelling, is determined to not create a physical hazard or public health nuisance and its location is documented and retained by the board of health when:
- (1) The use of a lot changes and the owner of the STS wishes to retain the system for future use; or
    - (a) If a system is retained for future use, the owner shall ensure that all openings into the system are properly secured against accidental or unauthorized entry.
    - (b) Upon reconnection of the STS, the board of health may require a permit for alteration of the system to ensure compliance with the rules of this chapter and prevent a public health nuisance.
  - (2) The owner of a system wishes to retain a STS or applicable component of a STS for uses other than sewage treatment.
- (C) The owner of the system shall have the contents of all tanks, dosing tanks, pretreatment components, leach wells and cesspools, and any other component which may pose a collapse hazard pumped and removed by a registered septage hauler. If applicable, solid materials such as filter media, mechanical devices, and other STS components, shall be taken to an approved solid waste disposal facility or otherwise legally disposed or reused in a manner that prevents a public health nuisance and contamination of surface or ground water.
- (D) Upon removal of their contents, tanks, dosing tanks, pretreatment components, leach wells and cesspools, and any other component of the STS shall be removed or properly abandoned by one of the following methods:
- (1) The top shall either be completely removed or collapsed and at least one side collapsed to prevent containment of water in the abandoned tank or component. The resulting void shall be filled to the ground surface with inert and nonhazardous materials such as gravel or other coarse aggregate, or soil in an amount and manner that compensates for settling and prevents ponding of surface water; or
  - (2) The tank or component shall be completely filled with compacted inert material of sufficient strength and volume to prevent settling, collection of water, and/or collapse. All access points to the abandoned tank or component must be permanently secured or sealed.
- (E) The board of health may require a permit for abandonment of a STS and establish a permit fee in accordance with paragraph (D)(12) of rule 3701-29-05 of the Administrative Code.
- (F) Any person who abandons a STS shall obtain a permit and inspection, if required by the board of health. The board of health shall be notified in writing within thirty days that the STS has been properly abandoned, and shall provide the following information on a form prescribed by the director to be retained by the board of health:
- (1) The owner and location of the abandoned STS and the date of abandonment;

- (2) The name of the registered septage hauler that removed the contents of the tanks, dosing tanks, and/or pretreatment components; and
- (3) The name of the person or registered installer that performed the STS abandonment and the manner in which the tanks, dosing tanks, and/or pretreatment components were abandoned or removed.



**3701-29-22 Variances and more stringent standards.**

- (A) A board of health may grant a variance from the requirements of this chapter when a person has made written application for a variance to the board requesting the variance from a specified rule or rules and the applicant shows that because of practical difficulties, or other special conditions, compliance with this chapter will cause unusual and unnecessary hardship. The board of health shall not grant a variance that would defeat the spirit and general intent of this chapter or is otherwise contrary to the public interest, adversely affect the public health, cause contamination of the environment, or not comply with the requirements of Chapter 3718. of the Revised Code. A board of health shall maintain a list of all variances to this chapter and shall provide the name and address of the person granted a variance, the reason for granting the variance, and a copy of the variance request to the department of health by the first day of April each year.
- (B) Experimental systems may be permitted by the board of health under the provisions of paragraph (A) of this rule provided the director of health concurs in writing with the design, evaluation, and operation and maintenance plan.
- (C) As provided in divisions (B)(1) and (B)(2) of section 3718.02 of the Revised Code and in accordance with section 3709.20 or 3709.21 of the Revised Code, as applicable, the board of health may adopt more stringent standards governing STS than those established under this chapter when local conditions support their adoption. As provided in division (C) of section 3718.05 of the Revised Code, more stringent standards shall be subject to review and approval by the director of health.
- (D) STS components or systems differing in design or principle of operation from those set forth in rules 3701-29-01 to 3701-29-23 of the Administrative Code, may qualify for approval as a special device or system upon review and recommendation by the sewage treatment systems technical advisory committee to the director of health as authorized under section 3718.04 of the Revised Code. A comprehensive design review, tests or sampling results, and related investigations must demonstrate that any such component or system produces results equivalent to those obtained by STS components or systems complying with such regulations. Such approval shall be obtained in writing from the director of health.

**3701-29-23 Verification of compliance and enforcement.**

- (A) The board of health may at any reasonable time inspect any STS, part thereof, or proposed STS site, to conduct sampling, collect data, or perform other activities necessary to assure compliance with this chapter.
- (B) The board of health may conduct an inspection when:
- (1) There is a good faith complaint regarding the system using forms and procedures developed by the board of health;
  - (2) There is probable cause for an inspection, including but not limited to, the presence of odors, untreated or poorly treated effluent, or sewage discharging to the surface of the ground, streams or water ways, discharge to ground water, drainage or dry wells, cesspools, sinkholes or other unauthorized structures or systems;
  - (3) Proof of required maintenance has not been provided by the owner of the STS as required in paragraph (D) of 3701-29-19 of the Administrative Code. The board of health shall provide written notice to the owner of a STS of the option to provide proof of maintenance in lieu of inspection by the board, and the reasonable cost of the inspection which may be assessed to the STS owner; or
  - (4) A board of health may inspect a STS without prior notice in any instance in which the board has probable cause to believe the system is endangering or threatening to endanger public health. A board of health may assess a fee established under rule 3701-29-05 of the Administrative Code for the costs of effluent testing or evaluation to the owner of the STS that is being investigated.
- (C) No person shall violate Chapter 3718. of the Revised Code, this chapter, orders issued pursuant to these chapters by the board of health, or the conditions of a registration or permit issued in accordance with this chapter. Upon determining noncompliance, the board of health shall notify the owner or other responsible party of the determination of noncompliance. The board of health notification shall specify any necessary corrective action and the time line for compliance, as applicable. Emergency orders and enforcement action shall be conducted in accordance with sections 3718.09, 3718.10, and 3718.99 of the Revised Code.
- (D) The board of health shall give notice and an opportunity for a hearing, pursuant to section 3718.11 of the Revised Code, to any reason described in division (A)(18) of section 3718.02 of the Revised Code. Reasonable attempts to notify the public of the opportunity for a hearing shall include posting of the following language: "An opportunity for a hearing will be provided upon written request to any landowner affected regarding the denial of an installation, operation, or alteration permit for a sewage treatment system; the imposition of a condition on the installation of a sewage treatment system; the required replacement of a sewage treatment system; or any other final order or decision of a board of health that is made under Chapter 3718. of the Revised Code concerning that which a property owner is claiming to be aggrieved or adversely affected."
- (1) When a board of health receives a written request for a hearing the board shall provide a written notice to the affected owner not less than fourteen days prior to the hearing.
  - (2) The board of health, at its discretion, may grant a written request from the owner to reschedule the hearing date.
  - (3) The owner shall be provided the opportunity to submit information, evidence, or witness testimony or arguments at the hearing. The property owner shall be allowed to designate a representative to present his position at the hearing.

- (4) The hearing shall be open to the public and the board of health, at its discretion, may hear concerns from constituents present at the hearing.
- (5) Failure of the owner to appear at the hearing shall not prevent the board of health from taking action on the request.
- (6) The board of health shall take action on any matter brought before them through this process and provide a written decision concerning the request within ten days. Written minutes or a tape recording may be used to record the hearing and serve as the required written decision.